

 EFFEBI



CATALOGUE 2005

BRASS BALL VALVES - BUTTERFLY VALVES - INDUSTRIAL VALVES

INDEX

The Company _____	pag.	1
Company Certifications _____	pag.	2
Products Certifications _____	pag.	3
Patent _____	pag.	4

Brass ball valves

Total _____	pag.	5
Kosmos _____	pag.	7
Mercury _____	pag.	9
Galaxy _____	pag.	11
Aster _____	pag.	13
Comet _____	pag.	15
Venus _____	pag.	17
Minerva _____	pag.	25
Venus with nut for gas meters NEW	pag.	27
Lpg NEW	pag.	28
Flare NEW	pag.	30
Kombi NEW	pag.	32
Copper-Copper NEW	pag.	34
Triflux _____	pag.	35
Delta _____	pag.	36
Olympic _____	pag.	37
Rolly _____	pag.	38
Miniball _____	pag.	39
Incas K _____	pag.	41
Incas M _____	pag.	42
Incas Extra _____	pag.	43
Space Dx/Sx NEW	pag.	45
Manifold K _____	pag.	47
Manifold M _____	pag.	48
Manifold A _____	pag.	49
Manifold angle _____	pag.	50
Extension NEW	pag.	51
Galaxy with nut for water meters NEW	pag.	52
Tappy _____	pag.	53
Hipress _____	pag.	55
Total Extra _____	pag.	56
Airy _____	pag.	57
Drainy _____	pag.	58
Aster with drain NEW	pag.	59
Sonda NEW	pag.	60
Isis _____	pag.	61
Y Strainer valve NEW	pag.	63

Brass joints for metal tubes

Kronos _____	pag.	65
--------------	------	----

Butterfly valves

Atlantis _____	pag.	67
Atlantis 40 _____	pag.	69
Atlantis with pneumatic actuator _____	pag.	71
Atlantis 40 with pneumatic actuator _____	pag.	73
Polaris _____	pag.	75
Polaris 40 _____	pag.	77
Polaris with pneumatic actuator _____	pag.	79
Polaris 40 with pneumatic actuator _____	pag.	81

Industrial valves

Sun WP _____	pag.	83
Sun WP with pneumatic actuator _____	pag.	85

Vega _____	pag.	87
Alba _____	pag.	89
Sunny _____	pag.	91
Minibinox _____	pag.	93
Monoblock AISI 316 _____	pag.	95
Monoblock A 105 _____	pag.	97
Monoblock TI _____	pag.	99
Titan _____	pag.	101
Titan with pneumatic actuator _____	pag.	103
Argos _____	pag.	105
Argos with pneumatic actuator _____	pag.	107
Moon AISI 316 _____	pag.	109
Moon AISI 316 with pneumatic actuator _____	pag.	111
Moon AISI 304 _____	pag.	113
Moon AISI 304 with pneumatic actuator _____	pag.	115
Moon A 105 _____	pag.	117
Moon A 105 with pneumatic actuator _____	pag.	119
Moon OT 58 _____	pag.	121
Moon OT 58 with pneumatic actuator _____	pag.	123
Moon ND AISI 316 _____	pag.	125
Moon ND AISI 316 with pneumatic actuator _____	pag.	127
Moon ND A 105 _____	pag.	129
Moon ND A 105 with pneumatic actuator _____	pag.	131
Moon PN 64/ANSI 300 _____	pag.	133
Moon CR _____	pag.	135
Moon 3W _____	pag.	137
Selene AISI 316 _____	pag.	139
Selene AISI 316 with pneumatic actuator _____	pag.	141
Selene A 105 _____	pag.	143
Selene A 105 with pneumatic actuator _____	pag.	145
Antares AISI 316 _____	pag.	147
Antares AISI 316 with pneumatic actuator _____	pag.	149
Antares A 105 _____	pag.	151
Antares ND A 105 with pneumatic actuator _____	pag.	153
Olympic with pneumatic actuator _____	pag.	155
Tristar _____	pag.	157
Gemini _____	pag.	159
Gemini with pneumatic actuator _____	pag.	161
Triflux with pneumatic actuator _____	pag.	163
Delta with pneumatic actuator _____	pag.	165
Total Steelball _____	pag.	167
Total Steelball with pneumatic actuator _____	pag.	169
Hipress with pneumatic actuator _____	pag.	171
Lybra with pneumatic actuator _____	pag.	173
Pneumatic actuator _____	pag.	175

Accessories and spare parts

Spare parts _____	pag.	177
Spare parts for butterfly valves _____	pag.	182
Valves accessories _____	pag.	183
Actuator accessories _____	pag.	185
Diagrams _____	pag.	187
Corrosion strength table _____	pag.	188
Table Flange UNI/DIN - Flange ANSI _____	pag.	196
Table _____	pag.	197
Protection rate of boxes _____	pag.	198

THE COMPANY

During the last years EFFEBI, with thirty years' experience in the production of brass ball valves, has operated in all fields of civil and industrial plant engineering, offering a vast range of increasingly innovative, tried and tested shut-off valves.

Supported by strictly controlled quality, certified according to ISO 9001:2000, EFFEBI has now added fittings and a full range of industrial valves and butterfly valves for civil and industrial use to its brass ball valve lines. Service is assured by facilities of suitable size, by a high level internal organization and by a sales network always on call and responsive to the customer's needs.



EFFEBI

COMPANY CERTIFICATIONS

In 1991 Effebi obtained – among the first companies in its business field – the quality certification according to ISO 9002; in 1995 it was one of the first companies in Italy which got ISO 9001 certification, the strictest quality standard certification, which includes also the engineering and design of the products. During 2001, Effebi updated again its quality certification, to assimilate the changes introduced by ISO 9001:2000. These are important improvements, which concern the company dynamics, such as the “customer satisfaction”, which evaluates and improves the comprehensive satisfaction level of the customers and an attention more focused on human resources, to bear out the theory which asserts that people form the companies.

CE-PED COMPLIANCE

The European Directive 97/23/CE for valves has the aim to protect the consumers against the risks of bursting in equipments under pressure. Ball valves are submitted to this regulation and Effebi has since long time spent all the necessary efforts to conform its products; from June 2002 all our valves are manufactured according to the Directive and, if necessary, they have the CE logo stamped on the body. Our choice was to conform our products and require the CE logo putting our valves in the most limiting list, granting the highest safety level to our customers.

We have also required the intervention of an international authority (the Buro Veritas), which has checked and will oversee in the future all the production procedures, from the planning to the final tests.

“Q AVR” QUALITY BRAND

During last February, Effebi supported a project promoted by Anima-AVR, oriented toward the introduction of an Italian Brand for manufacturers of high quality valves, taps and fittings. The project involved some Italian producers chosen through many quality qualifications, production and organizing performances.

The aim was to make a brand which gives importance to the main features of the best Italian manufacturers: experience, innovation, quality-oriented structure, certifications from main Italian and International Authorities, after sales service, personnel training.

The result was the introduction of “Q AVR” Quality Brand, which our Company achieved on June 2002.



PRODUCT CERTIFICATION

Effebi can boast about a long lasting tradition in the certification of its products, issued by recognized certification authorities, both in the industrial countries and in developing countries. More than fifty certifications and approvals from not less than 20 different countries, confirms the quality and reliability of our products, above all, according to the regulations of each sector, but also according to the equipment specifications. Effebi has focused its greatest attention on natural gas applications, updating our products according to the regulations.



FRANCE
ROB - GAZ



GERMANY
DIN - DVGW
Deutscher Verein des
Gas- und Wasserfaches



DENMARK
Boligministeriet Byggestyrelsen
Godkendelse



DENMARK
DG / Danmarks
Gasmateriel



SWITZERLAND / SVGW
Schweizer Verein von Gas- und
Wasserfachmännern



ENGLAND
Evaluation & Testing Centre



ENGLAND
BRITISH GAS
British Gas Corporation Research &
Technology Division



SINGAPORE
Institute of Standards
and Industrial Research



POLAND
IGNG
Instytut Górnictwa
Naftowego i Gazownictwa



RUSSIA
СЕРТИФИКАТ СООТВЕТСТВИЯ
СИСТЕМА СЕРТИФИКАЦИИ
ГОСТ Р ГОССТАНДАРТ РОССИИ



FRANCE
Attestation Conformité
Sanitaire



AUSTRIA / ÖVGW
Österreichische
Vereinigung für das
Gas- und Wasserfach



AUSTRALIA
Watermark Licence



AUSTRALIA / AGA
The Australian Gas
Association



NORWAY / DNV
Det Norske
veritas



CZECH REPUBLIC
Strojrenský Zkušební
Ústav STROJRENŠKÝ ZKUŠEBNÍ ÚSTAV



HUNGARY
Építésügyi
Minőségellenőrző Intézet



BELGIUM
AGB-BGV



USA - CANADA
CSA
Canadian Standards Association
Underwriters Lab. Inc.



POLSKA
APROBATA TECHNICZNA
Centralny Ośrodek Badawczo - Rozwojowy
Techniki Instalacyjnej "INSTAL"

PATENT

The stem packing assembled in EFFEBI ball valves is composed of conical seals, self-adjusting in accordance with a patent filed in the major industrialized countries.

This system has unique features:

- **it is automatic:** as the inner pressure increases a proportional sealing is achieved thanks to the reciprocal wedging of the sealing couples;
- **it is dynamic:** the two conical seals on the stem

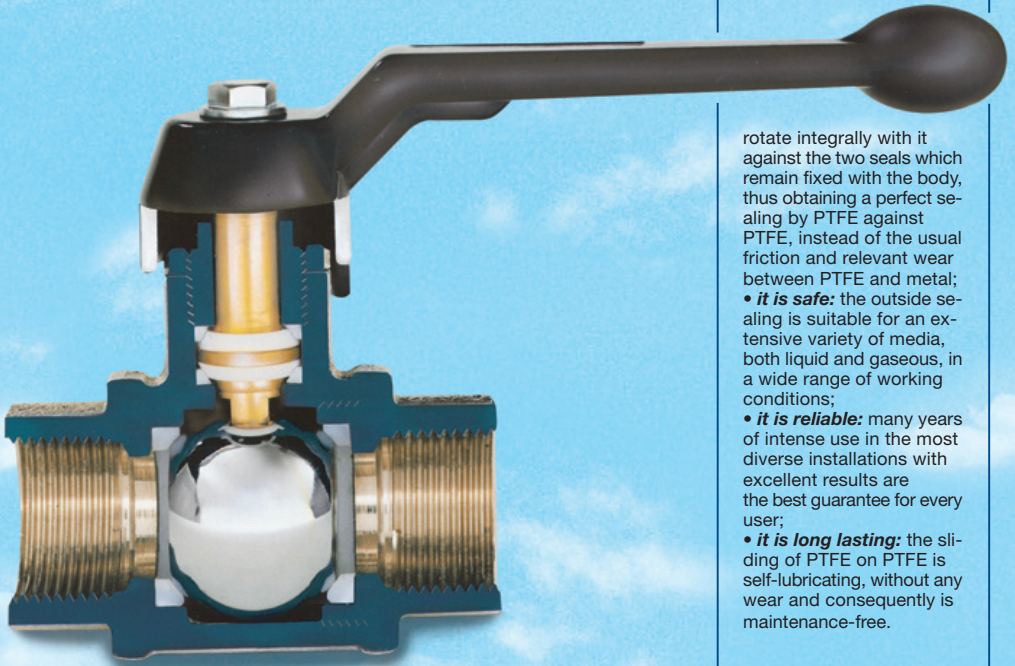

rotate integrally with it against the two seals which remain fixed with the body, thus obtaining a perfect sealing by PTFE against PTFE, instead of the usual friction and relevant wear between PTFE and metal;

- **it is safe:** the outside sealing is suitable for an extensive variety of media, both liquid and gaseous, in a wide range of working conditions;

- **it is reliable:** many years of intense use in the most diverse installations with excellent results are the best guarantee for every user;

- **it is long lasting:** the sliding of PTFE on PTFE is self-lubricating, without any wear and consequently is maintenance-free.

TOTAL

PN 100

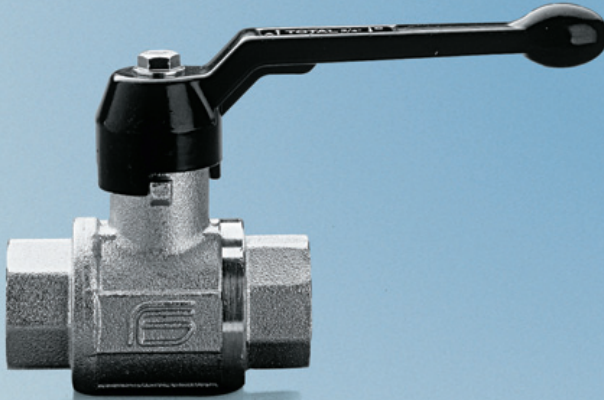

Art. 0101 F/F with lever in al. Available range: from 1/8" to 3" **Art. 0102** M/F with lever in al. Available range: from 1/8" to 2 1/2" **Art. 0103** M/M with lever in al. Available range: from 1/8" to 2 1/2"



Art. 0121 F/F with T-handle in aluminium from 1/8" to 1"
Art. 0122 M/F with T-handle in aluminium from 1/8" to 1"
Art. 0123 M/M with T-handle in aluminium from 1/8" to 1"



Art. 0141 F/F with square cap from 3/8" to 2"
Art. 0142 M/F with square cap from 3/8" to 2"
Art. 0143 M/M with square cap from 3/8" to 2"

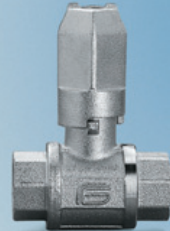

Art. 0151 F/F with underground adaptor from 3/8" to 3"
Art. 0152 M/F with underground adaptor from 3/8" to 2 1/2"
Art. 0153 M/M with underground adaptor from 3/8" to 2 1/2"



Art. 0161 F/F with sealing cap from 3/8" to 3"
Art. 0162 M/F with sealing cap from 3/8" to 2 1/2"
Art. 0163 M/M with sealing cap from 3/8" to 2 1/2"



Art. 0181 F/F with extension and lever from 3/8" to 3"

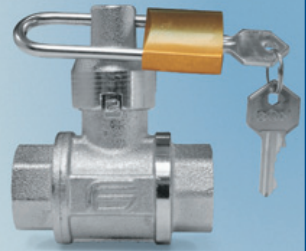

Art. 0161..L F/F Lockable from 3/4" to 3"

TOTAL

TECHNICAL FEATURES:

Temperature limits: for fluids from -20°C to +130°C (peak temperature +150°C)
for gas from -20°C to +60°C

Pressure limits: for fluids from 100 bar to 40 bar
for gas MOP5

Application fields:

TOTAL series is used in presence of special performance requirements, for example in the installations of: gas and water distribution, industrial and civil heating, water plants at medium and high pressure, hydraulics, oil and petrochemical fields, non aggressive media, steam and vacuum. On request available in degreased version.

Threaded end connections:

- Standard female and male according to ISO 7/1
- On request NPT or BSPT

Operation devices:

aluminium lever and T-handle, square cap, underground adaptor, sealing cap.
Available colours: black, red, green, blue, yellow

SPECIFIC FEATURES:

- the TOTAL valve, with full bore, is an extremely robust product
- with perfect air bubble sealing
- does not need any maintenance, is equipped with wrapping seats ensuring long life cycles
- four self-adjusting cone-shaped seals, with PTFE-PTFE sliding, therefore without wear, form two sealings with automatic functioning
- an adjusting gland allows the sealing reset on the stem
- all valves are tested according to a strict procedure covering severe inspections on the entire production
- the valve is approved according to DIN-DVGW standards: such approval was obtained for the first time in 1974 and then always renewed up to the present one.
- tested for vacuum at 1×10^{-2} mbar
- on request the valve is available with ATEX certificate

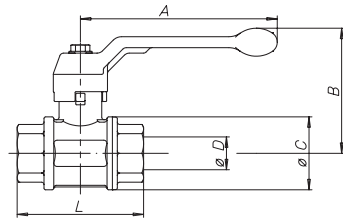
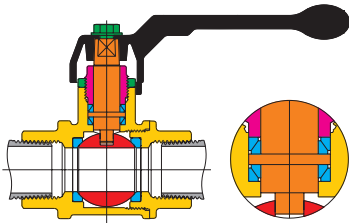

LIST OF COMPONENTS: description/materials/treatments

body and threaded end	yellow	hot stamped from bar	CW617N	UNI EN 12165
gland	violet	machined from bar	CW614N	UNI EN 12164
gland nut	green	machined from bar	CW614N	UNI EN 12164
stem	orange	machined from bar	CW617N	UNI EN 12164
chromium pl. polished ball	red	machined from bar	CW617N	UNI EN 12164
seats	blue	virgin PTFE		
operation device	black	die-cast alumini. alloy polyur c.		UNI 5076
fixing screw	green	zinc plated steel		
surface treatment	—	brilliant nickel-plating		

GENERAL TABLE: valve dimensions per type and size

nominal diameter	6	8	10	15	20	25	32	40	50	65	80
gas size in inch	1/8"	1/4"	3/8"	1/2"	3/4"	1"	1 1/4"	1 1/2"	2"	2 1/2"	3"
Ø D bore mm	8	8	10	15	20	25	32	40	50	65	80
A mm	75	75	100	100	120	120	150	150	175	280	280
B mm	52	52	61	64	76	80	98	104	119	155	167
Ø C mm	23	23	29	36	45	54	65	79	96	119	144
female L mm	50	51	55	69	77	89	103	114	134	160	185
female weight gr	160	150	245	370	635	890	1555	2315	3630	5540	8440
male L mm	51	55	60	75	86	99	113	125	147	166	—
female weight gr	147	152	255	379	656	923	1650	2400	3910	5520	—
male L mm	52	58	66	82	95	108	124	136	161	172	—
male weight gr	150	152	267	381	675	953	1685	2532	4050	5700	—

PRESSURE/TEMPERATURE DIAGRAM

at each pressure level corresponds a specific admissible temperature level and viceversa

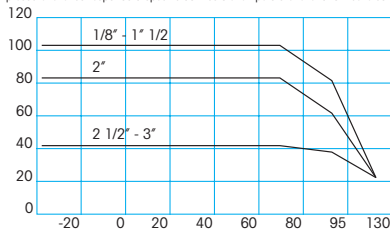

LOSS OF HEAD DIAGRAM:

the Kv value is the port capacity causing a pressure drop of 1 bar.

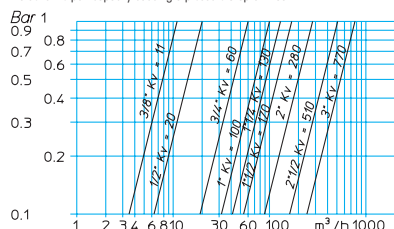

KOSMOS

PN 80

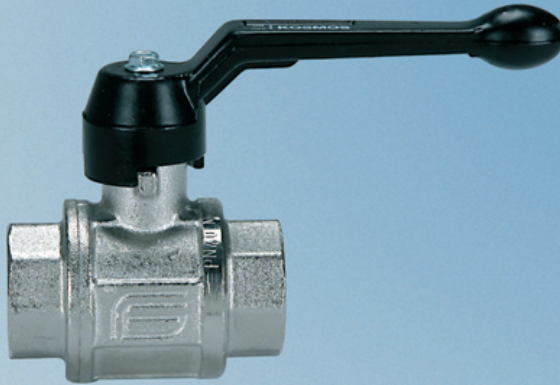

Art. 0301 F/F with lever in aluminium. Available range: from 1/8" to 3"

Art. 0302 M/F with lever in aluminium. Available range: from 1/8" to 2"



Art. 0321 F/F with T-handle in aluminium from 1/8" to 1"

Art. 0322 M/F with T-handle in aluminium from 1/8" to 1"



Art. 0381 F/F with extension and lever from 1/2" to 3"

Art. 0382 M/F with extension and lever from 1/2" to 2"

KOSMOS

TECHNICAL FEATURES:

Temperature limits: for fluids from -20°C to +130°C (peak temperature +150°C)
Pressure limits: for fluids from 80 bar to 40 bar

Application fields:

KOSMOS series is recommended in the following installations: water distribution, industrial and civil heating, water plants at medium and high pressure, hydraulics and pneumatics, oil and petrochemical fields, non aggressive media.

Threaded end connections:

• Standard Female and male according to ISO 228/1

Operation devices:

Aluminium lever and T-handle.

Available colours:

black

SPECIFIC FEATURES:

- the KOSMOS valve, with full bore, is a well dimensioned product, to be used in all those cases when high safety is required, thanks to the excellent solidity features, good performance guarantee, sealing capacity at pressure and temperature variations and working endurance
- does not need any maintenance, is equipped with wrapping seats ensuring long life cycles
- two self-adjusting cone-shaped seats and an antifriction ring, with PTFE-PTFE sliding, therefore without wear, guarantee a safe sealing
- all valves are tested according to a strict procedure covering severe inspections on the entire production

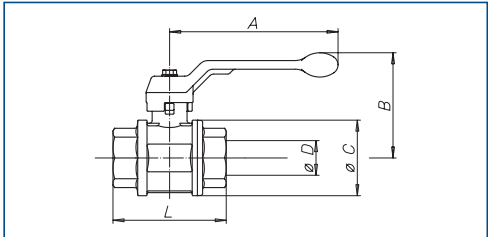
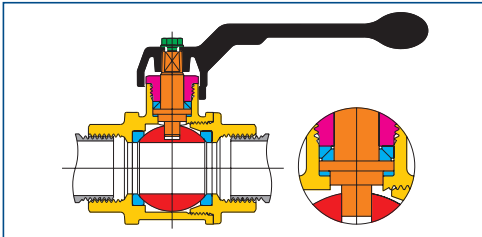

LIST OF COMPONENTS: description/materials/treatments

body and threaded end	yellow	hot stamped from bar	CW617N	UNI EN 12165
gland	violet	machined from bar	CW614N	UNI EN 12164
stem	orange	machined from bar	CW617N	UNI EN 12164
nickel chromium pl. polished ball	red	machined from bar	CW617N	UNI EN 12164
seals	blue	virgin PTFE		
operation device	black	die-cast alumin. alloy polyur c.		UNI 5076
fixing screw	green	zinc plated steel		
surface treatment	—	brilliant nickel-plating		

GENERAL TABLE: valve dimensions per type and size

nominal diameter	6	8	10	15	20	25	32	40	50	65	80
gas size in inch	1/8"	1/4"	3/8"	1/2"	3/4"	1"	1 1/4"	1 1/2"	2"	2 1/2"	3"
Ø D bore mm	8	8	10	15	20	25	32	40	50	65	80
A mm	75	75	70	97	97	110	140	140	170	280	280
B mm	52	52	49	57	61	70	84	91	102	155	167
Ø C mm	23	23	28	35	43	52	64	78	95	119	144
female	L mm	50	41	46	56	65	76	86	103	120	146
female	weight gr	160	135	165	280	435	680	1165	1870	3070	5315
male	L mm	52	47	56	66	76	87	97	115	134	159
female	weight gr	159	145	183	310	470	750	1270	1950	3160	5530

PRESSURE/TEMPERATURE DIAGRAM

at each pressure level corresponds a specific admissible temperature level and viceversa

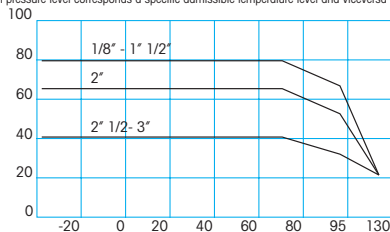

LOSS OF HEAD DIAGRAM:

the Kv value is the port capacity causing a pressure drop of 1 bar.

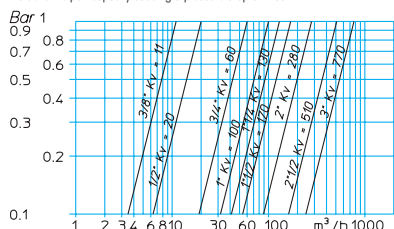

MERCURY

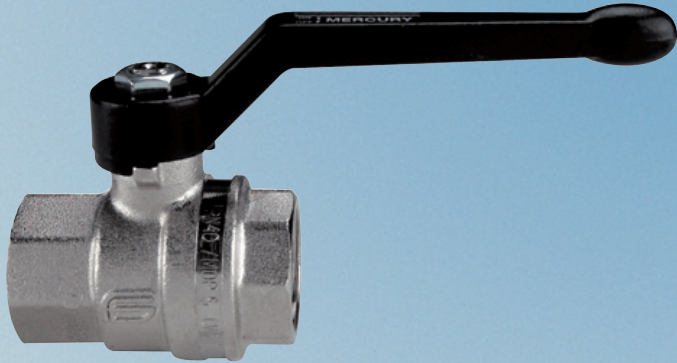

Art. 0401 F/F with lever in aluminium. Available range: from 1/4" to 4"

Art. 0402 M/F with lever in aluminium. Available range: from 1/4" to 2" 1/2"



Art. 0411 F/F with lever in steel from 1/4" to 4"

Art. 0412 M/F with lever in steel from 1/4" to 2" 1/2"



Art. 0421 F/F with T-handle in aluminium from 1/4" to 1"

Art. 0422 M/F with T-handle in aluminium from 1/4" to 1"



Art. 0441 F/F with square cap from 1/4" to 4"

Art. 0442 M/F with square cap from 1/4" to 2" 1/2"



Art. 0461 F/F with sealing cap from 1/4" to 4"

Art. 0462 M/F with sealing cap from 1/4" to 2" 1/2"

MERCURY

TECHNICAL FEATURES:

Temperature limits: for fluids from -15°C to +120°C (peak temperature +150°C)

Pressure limits: for fluids from 63 bar to 40 bar

Application fields:

MERCURY series is frequently applied to the following installations: water distribution, industrial and civil heating, water plants at medium pressure, hydraulics and pneumatics, agriculture.

Threaded end connections:

• Standard Female and male according to ISO 228/1

Operation devices:

Aluminium lever and T-handle, steel lever handle, square cap, sealing cap.

Available colours:

black.

SPECIFIC FEATURES:

- the MERCURY valve, with full bore, is a high reliability product, with remarkable versatility in the industrial and civil sector
- blow-out proof stem
- does not need any maintenance, is equipped with wrapping seats ensuring long life cycles
- an anti-friction ring forms the first automatic sealing at high pressure
- two self-adjusting cone-shaped seals, with PTFE-PTFE sliding, therefore without wear, form the second sealing at low pressure
- 1 O-Ring in NBR for sealing at low pressure and vacuum.
- all valves are tested according to a strict procedure covering severe inspections on the entire production

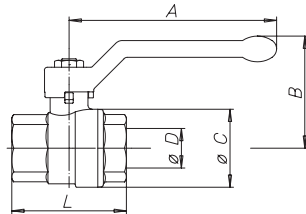
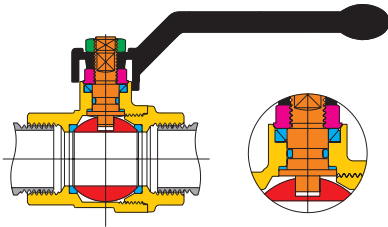
LIST OF COMPONENTS: description/materials/treatments

body and threaded end	yellow	hot stamped from bar	CW617N	UNI EN 12165
gland	violet	machined from bar	CW614N	UNI EN 12164
stem	orange	machined from bar	CW617N	UNI EN 12164
chromium pl. polished ball	red	machined from bar	CW617N	UNI EN 12164
seals	blue	virgin PTFE		
stem packing O-ring	blue	NBR		DIN 3535
operation device	black	die-cast alumim. alloy polyur. c.		UNI 5076
fixing nut	green	zinc plated steel		
surface treatment	—	brilliant nickel-plating		

GENERAL TABLE: valve dimensions per type and size

nominal diameter	8	10	15	20	25	32	40	50	65	80	100	
gas size in inch	1/4"	3/8"	1/2"	3/4"	1"	1 1/4"	1 1/2"	2"	2 1/2"	3"	4"	
Ø D bore mm	8	10	15	20	25	32	40	50	65	80	100	
A mm	85	85	85	105	105	130	130	165	260	260	260	
B mm	41	41	49	57	61	70	76	92	116	127	142	
Ø C mm	23	24	32	40	48	60	72	88	111	135	167	
female	L mm	37	42	50	58	69	81	93	110	133	156	192
female		weight gr	100	120	190	325	510	850	1310	2245	3350	5380
male	L mm	43	50	60	70	79	92	104	121	147	—	—
female		weight gr	106	135	212	367	560	950	1480	2500	3550	—

PRESSURE/TEMPERATURE DIAGRAM

at each pressure level corresponds a specific admissible temperature level and viceversa

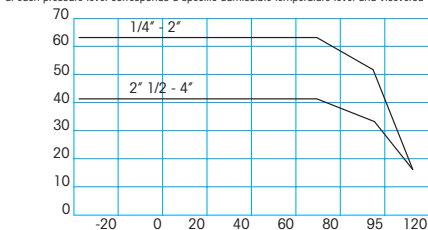
LOSS OF HEAD DIAGRAM:

the Kv value is the port capacity causing a pressure drop of 1 bar.

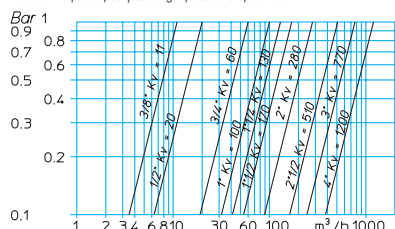

GALAXY

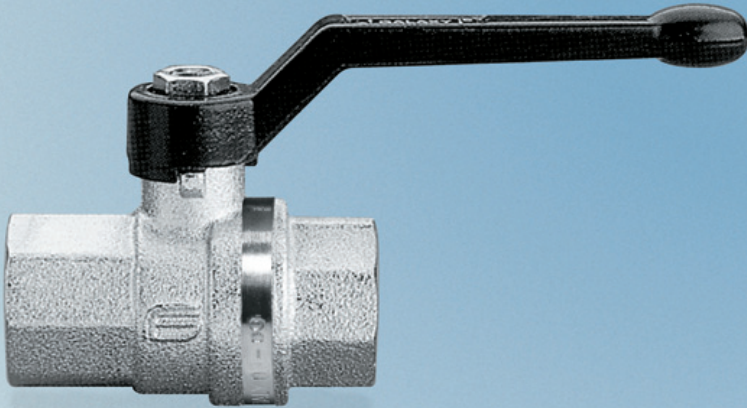

Art. 0501 F/F with lever in aluminium. Available range: from 1/4" to 4" **Art. 0502** M/F with lever in aluminium. Available range: from 1/4" to 2" 1/2" **Art. 0503** M/M with lever in aluminium. Available range: from 3/8" to 2"



Art. 0511 F/F with lever in steel from 1/4" to 1"
Art. 0512 M/F with lever in steel from 1/4" to 2" 1/2"



Art. 0521 F/F with T-handle from 1/4" to 1"
Art. 0522 M/F with T-handle from 1/4" to 1"



Art. 0551 F/F with underground adaptor from 1/4" to 4"
Art. 0552 M/F with underground adaptor from 1/4" to 2" 1/2"



Art. 0581 F/F with extension and lever from 1/4" to 4"
Art. 0582 M/F with extension and lever from 1/4" to 2" 1/2"



Art. 0591 F/F with gear handle from 1/4" to 2"
Art. 0592 M/F with gear handle from 1/4" to 2"

GALAXY

TECHNICAL FEATURES:

Temperature limits: for fluids from -15°C to +120°C (peak temperature +150°C)
 Pressure limits: for fluids from 63 bar to 40 bar

Application fields:

GALAXY series is mainly employed in the following installations: water distribution, industrial and civil heating, water plants at medium pressure, hydraulics and pneumatics, agriculture.

Threaded end connections:

- Standard Female/Female according to ISO 7/1 Rp
- Male according to ISO 7/1 R

Operation devices:

Aluminum lever and T-handle, steel lever handle. Rallenly gear handle. Underground adaptor, extension and lever.

Available colours:

black, red, blue.

SPECIFIC FEATURES:

- the GALAXY valve, with full bore, is a high reliability product, with remarkable operational flexibility in the industrial and civil sector
- provides good performances also in industrial installations apart from heating, pneumatics and agriculture
- blow-out proof stem
- does not need any maintenance, is equipped with wrapping seats ensuring long life cycles
- an antifriction ring forms the first automatic sealing at high pressure
- two self-adjusting cone-shaped seals, with PTFE-PTFE sliding, therefore without wear, form the second sealing at low pressure
- 1 O-Ring in NBR for sealing at low pressure and vacuum.
- all valves are tested according to a strict procedure covering severe inspections on the entire production.

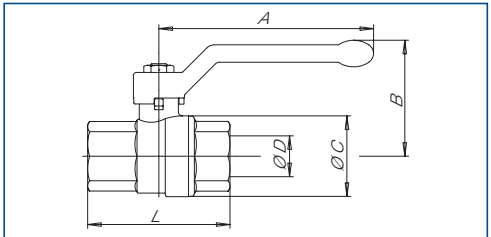
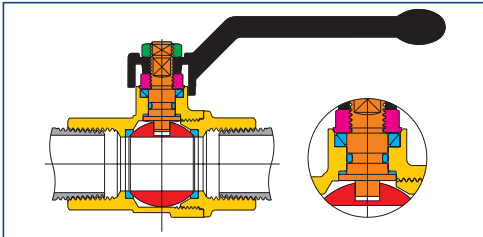
LIST OF COMPONENTS: description/materials/treatments

body and threaded end	yellow	hot stamped from bar	CW617N	UNI EN 12165
gland	violet	machined from bar	CW614N	UNI EN 12164
stem	orange	machined from bar	CW617N	UNI EN 12164
chromium pl. polished ball	red	machined from bar	CW617N	UNI EN 12164
seals	blue	virgin PTFE		
stem packing O-ring	blue	NBR		DIN 3535
operation device	black	die-cast alumin. alloy polyur. c.		UNI 5076
fixing nut	green	zinc plated steel		
surface treatment	—	brilliant nickel-plating		

GENERAL TABLE: valve dimensions per type and size

nominal diameter	8	10	15	20	25	32	40	50	65	80	100	
gas size in inch	1/4"	3/8"	1/2"	3/4"	1"	1 1/4"	1 1/2"	2"	2 1/2"	3"	4"	
Ø D bore mm	8	10	15	20	25	32	40	50	65	80	100	
A mm	85	85	85	105	105	130	130	165	260	260	260	
B mm	41	41	49	57	61	70	76	92	116	127	142	
Ø C mm	23	24	32	40	48	60	72	88	111	135	167	
female	L mm	49	51	61	70	84	98	108	130	159	182	219
female		weight gr	116	125	210	356	560	950	1400	2450	3770	5840
male	L mm	52	54	67	87	89	104	114	136	162	—	—
female	weight gr	113	140	220	380	583	980	1490	2520	3740	—	—

PRESSURE/TEMPERATURE DIAGRAM

at each pressure level corresponds a specific admissible temperature level and viceversa

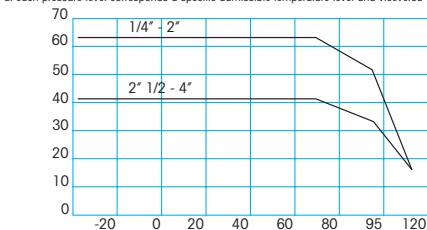
LOSS OF HEAD DIAGRAM:

the Kv value is the port capacity causing a pressure drop of 1 bar.

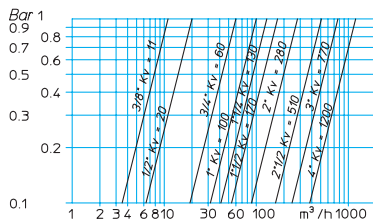

ASTER

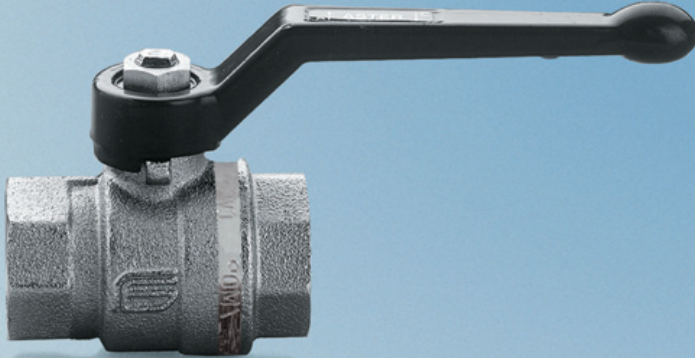

Art. 0801 F/F with lever in aluminium. Available range: from 1/4" to 4"

Art. 0802 M/F with lever in aluminium. Available range: from 1/4" to 2 1/2"



Art. 0806 M/M with lever in aluminium from 3/8" to 2"

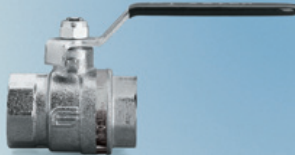

Art. 0811 F/F with handle in steel from 1/4" to 4"

Art. 0812 M/F with handle in steel from 1/4" to 2 1/2"



Art. 0821 F/F with T-handle from 1/4" to 1"

Art. 0822 M/F with T-handle from 1/4" to 1"



Art. 0827 F/H connector with T-handle from 3/8" to 3/4"

Art. 0828 M/H connector with T-handle from 3/8" to 3/4"



Art. 0881 F/F with extension and lever from 3/8" to 4"

Art. 0882 M/F with extension and lever from 3/8" to 2 1/2"



Art. 0891 F/F with gear handle from 3/8" to 2"

Art. 0892 M/F with gear handle from 3/8" to 2"

ASTER

TECHNICAL FEATURES:

Temperature limits: for fluids from -15°C to +100°C (peak temperature +130°C)
Pressure limits: for fluids from 40 bar to 40 bar

Application fields:

ASTER series guarantees good performances in the industrial and civil heating, water plants, hydraulics and pneumatics, agriculture.

Threaded end connections:

• Standard Female and male according to ISO 228/1

Operation devices:

Aluminium lever and T-handle, steel lever handle. Extension and lever, Rallenty.

Available colours:

black, red.

SPECIFIC FEATURES:

- the ASTER valve, with full bore, is compact, flexible and easy for installing
- blow-out proof stem
- does not need any maintenance, is equipped with wrapping seats ensuring long life cycles
- the stem packing is composed of 3 seals: two o-rings in NBR for low pressures and an antifriction ring in PTFE for high pressure
- all valves are tested to a strict procedure covering severe inspections on the entire production.

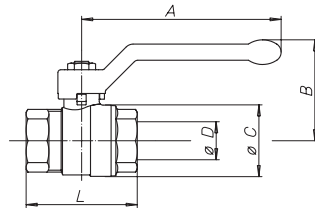
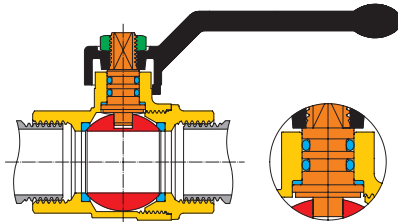

LIST OF COMPONENTS: description/materials/treatments

body and threaded end	yellow	hot stamped from bar	CW617N	UNI EN 12165
stem	orange	machined from bar	CW617N	UNI EN 12164
chromium pl. polished ball	red	machined from bar	CW617N	UNI EN 12164
seals	blue	virgin PTFE		
stem packing	blue	o-ring	NBR	DIN 3535
operation device	black	die-cast alumin. alloy polyur. c.		UNI 5076
fixing nut	green	zinc plated steel		
surface treatment	—	brilliant nickel-plating		

GENERAL TABLE: valve dimensions per type and size

nominal diameter	8	10	15	20	25	32	40	50	65	80	100
gas size in inch	1/4"	3/8"	1/2"	3/4"	1"	1 1/4"	1 1/2"	2"	2 1/2"	3"	4"
Ø D bore mm	10	10	15	20	25	32	40	50	65	80	100
A mm	85	85	85	105	105	130	130	165	260	260	260
B mm	42	42	46	53	57	70	76	92	116	127	142
Ø C mm	23	24	30	38	46	58	70	86	111	135	167
female	L mm	37	42	50	58	69	81	93	110	133	156
female	weight gr	100	120	160	285	450	743	1130	1767	3350	5380
male	L mm	43	49	54	70	79	91	104	122	151	—
female	weight gr	106	134	190	330	505	813	1160	1937	3550	—

PRESSURE/TEMPERATURE DIAGRAM

at each pressure level corresponds a specific admissible temperature level and viceversa

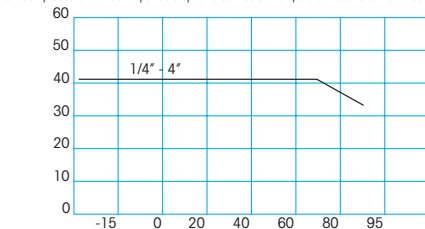

LOSS OF HEAD DIAGRAM:

the Kv value is the port capacity causing a pressure drop of 1 bar.

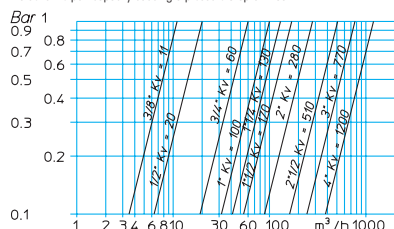

COMET

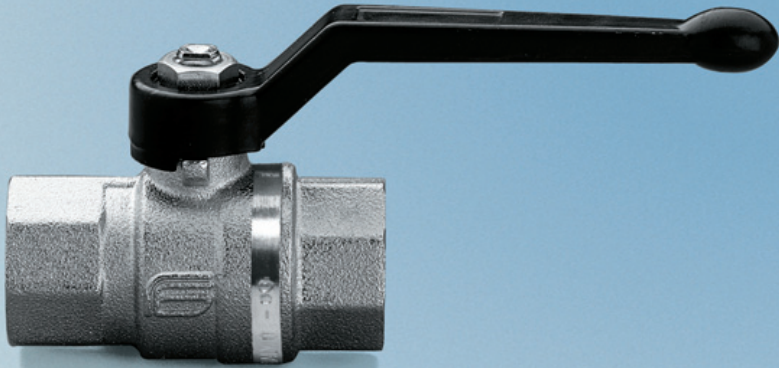

Art. 0901 F/F with lever in aluminium. Available range: from 1/4" to 4" **Art. 0902** M/F with lever in aluminium. Available range: from 1/4" to 2 1/2"



Art. 0911 F/F with lever in steel from 1/4" to 4"
Art. 0912 M/F with lever in steel from 1/4" to 2 1/2"



Art. 0921 F/F with T-handle from 1/4" to 1"
Art. 0922 M/F with T-handle from 1/4" to 1"



Art. 0941 F/F with square cap from 3/8" to 4"
Art. 0942 M/F with square cap from 3/8" to 2 1/2"



Art. 0961 F/F with sealing cap from 3/8" to 4"
Art. 0962 M/F with sealing cap from 3/8" to 2 1/2"

COMET

TECHNICAL FEATURES:

Temperature limits: for fluids from -15°C to +100°C (peak temperature +130°C)

Pressure limits: for fluids 40 bar

Application fields: COMET series is employed where the need of a safe valve, guaranteeing a faultless sealing in the industrial and civil heating, water plants, hydraulics and pneumatics, agriculture has to match a competitive price.

Threaded end connections:

- Standard Female according to ISO 7/1 Rp
- Male according to ISO 7/1R

Operation devices:

Aluminium lever and T-handle, steel lever handle.
Square cap, sealing cap.

Available colours:

black, red.

SPECIFIC FEATURES:

- the COMET valve, with full bore, is compact, flexible and easy for installing
- blow-out proof stem
- does not need any maintenance, is equipped with wrapping seats ensuring long life cycles
- the stem packing is composed of 3 seals: two O-rings for low pressures and an anti-friction ring in PTFE for high pressure
- all valves are tested according to a strict procedure covering severe inspections on the entire production.

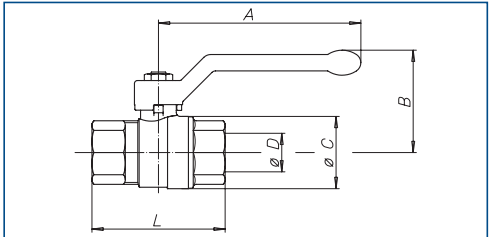
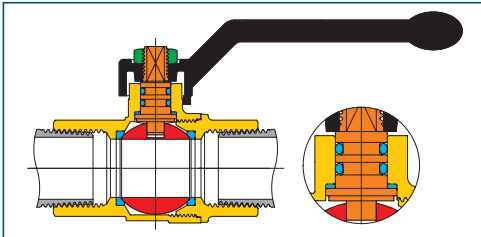

LIST OF COMPONENTS: description/materials/treatments

body and threaded end	yellow	hot stamped from bar	CW617N	UNI EN 12165
stem	orange	machined from bar	CW617N	UNI EN 12164
chromium pl. polished ball	red	machined from bar	CW617N	UNI EN 12164
seals	blue	virgin PTFE		
stem packing	blue	O-ring	NBR	DIN 3535
operation device	black	die-cast alumin. alloy polyur c.		UNI 5076
fixing nut	green	zinc plated steel		
surface treatment	—	brilliant nickel-plating		

GENERAL TABLE: valve dimensions per type and size

nominal diameter	8	10	15	20	25	32	40	50	65	80	100	
gas size in inch	1/4"	3/8"	1/2"	3/4"	1"	1 1/4"	1 1/2"	2"	2 1/2"	3"	4"	
Ø D bore mm	10	10	15	20	25	32	40	50	65	80	100	
A mm	85	85	85	105	105	130	130	165	260	260	260	
B mm	42	42	46	53	57	70	76	92	116	127	142	
Ø C mm	23	24	30	38	46	58	70	86	111	135	167	
female	L mm	49	50	61	70	84	98	108	130	159	182	219
female	weight gr	116	130	182	315	496	803	1150	1887	3770	5840	10130—
male	L mm	52	54	67	78	89	103	113	136	162	—	—
female	weight gr	113	140	200	350	530	850	1280	1967	3740	—	—

PRESSURE/TEMPERATURE DIAGRAM

at each pressure level corresponds a specific admissible temperature level and viceversa

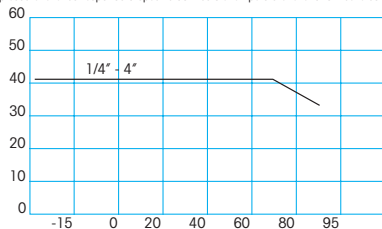

LOSS OF HEAD DIAGRAM:

the Kv value is the port capacity causing a pressure drop of 1 bar.

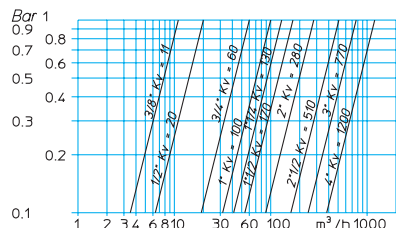

VENUS



Art. 1001 f/f with lever in aluminium from 1/4" to 4"

Art. 1002 m/f with lever in aluminium from 1/4" to 2 1/2"



Art. 1011 f/f with lever in steel from 1/4" to 4"

Art. 1012 m/f with lever in steel from 1/4" to 2 1/2"



Art. 1021 f/f with T-handle from 1/4" to 1"

Art. 1022 m/f with T-handle from 1/4" to 1"



Art. 1041 f/f with square cap from 1/4" to 4"

Art. 1042 m/f with square cap from 1/4" to 2 1/2"

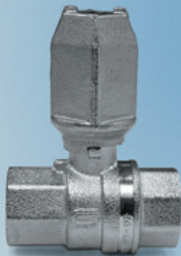

Art. 1051 f/f with underground adaptor from 1/4" to 4"

Art. 1052 m/f with underground adaptor from 1/4" to 2 1/2"



Art. 1061 f/f with sealing cap from 1/4" to 4"

Art. 1062 m/f with sealing cap from 1/4" to 2 1/2"



Art. 1021..F f/f with sealing drilling from 1/4" to 1"

Art. 1022..F m/f with sealing drilling from 1/4" to 1"

VENUS **ROB - GAZ - EN 331**

TECHNICAL FEATURES:

Temperature limits: for fluids from -15°C to +120°C (peak temperature +150°C)
 for gas from -20°C to +60°C

Pressure limits: for fluids from 63 bar to 40 bar
 for gas MOP5

Application fields:

VENUS series is particularly recommended in gas installations.

Threaded end connections:

- Standard female according to ISO 7/1 Rp
- male according to ISO 7/1

Operation devices:

aluminium lever and T-handle, steel lever handle, square cap, sealing cap, underground adaptor, sealing T-handle.

Available colours: yellow.

SPECIFIC FEATURES:

The VENUS valve, with full bore, has been designed to comply with the EN 331 European norm covering gas ball valves and is already certified. Thanks to its construction features it guarantees a high working reliability at low and very low pressures which are typical in gas installations.

- blow-out proof stem
- does not need any maintenance, is equipped with wrapping seats ensuring long life cycles
- an anti-friction ring forms the first automatic sealing at high pressure
- two self-adjusting cone-shaped seats, with PTFE-PTFE sliding, therefore without wear, form the second sealing at low pressure
- 1 O-Ring in NBR for sealing at very low pressure and vacuum
- All valves are tested according to a strict procedure covering severe inspections on the entire production.
- on request the valve is available with ATEX certificate

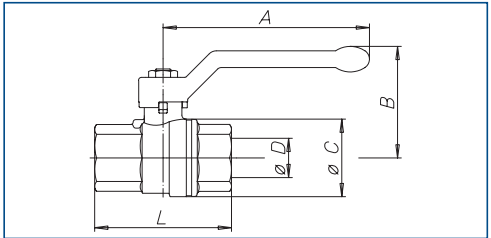
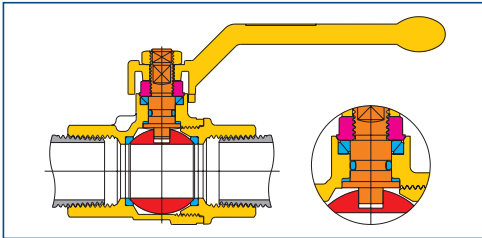
LIST OF COMPONENTS: description/materials/treatments

body and threaded end	yellow	hot stamped from bar	CW617N	UNI EN 12165
gland	violet	machined from bar	CW614N	UNI EN 12164
stem	orange	machined from bar	CW617N	UNI EN 12164
chromium pl. polished ball	red	machined from bar	CW617N	UNI EN 12164
seals	blue	virgin PTFE		
stem packing o-ring	blue	NBR		DIN 3535
operation device	yellow	die-cast alum. alloy polyur c.		UNI 5076
fixing nut	green	zinc plated steel		
surface treatment	—	brilliant nickel-plating		

GENERAL TABLE: valve dimensions per type and size

nominal diameter	8	10	15	20	25	32	40	50	65	80	100	
gas size in inch	1/4"	3/8"	1/2"	3/4"	1"	1 1/4"	1 1/2"	2"	2 1/2"	3"	4"	
Ø D bore mm	8	10	15	20	25	32	40	50	65	80	100	
A mm	85	85	85	105	105	130	130	165	260	260	260	
B mm	41	41	49	57	61	75	81	97	116	127	142	
Ø C mm	23	24	32	40	48	60	72	88	111	135	167	
female	L mm	49	50	61	70	84	98	108	130	159	182	219
female	weight gr	116	125	210	356	585	950	1400	2450	3770	5840	10130
male	L mm	52	54	67	78	89	104	114	136	162	—	—
female	weight gr	113	140	220	380	600	980	1490	2520	3740	—	—

PRESSURE/TEMPERATURE DIAGRAM

at each pressure level corresponds a specific admissible temperature level and viceversa

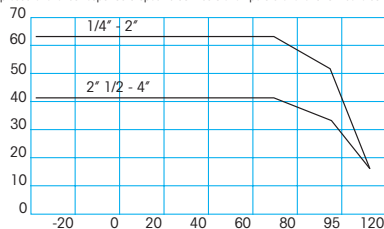

LOSS OF HEAD DIAGRAM:

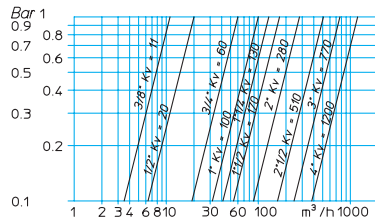
the Kv value is the port capacity causing a pressure drop of 1 bar.

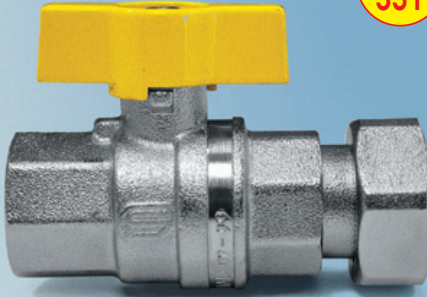

VENUS with nut

**EN
331**



Art. 1021..XG f/nut + tail

Art. 1022..XG m/nut + tail

TECHNICAL FEATURES:

Temperature limits: for fluids from -15°C to +120°C (peak temperature +150°C)
for gas from -20°C to +60°C

Pressure limits: for fluids 63 bar
for gas MOP 5

Operation devices:

Aluminium T-handle. Available colours: yellow.

Specific features:

The connections have sizes moved by one position. Nevertheless size 1/2" x 1/2" is also available. The valve body derives from VENUS, certified according to EN 331:

- blow-out proof stem
- does not need any maintenance, is equipped with wrapping seats ensuring long life cycles
- an anti-friction ring forms the first automatic sealing at high pressure
- two self-adjusting cone-shaped seals with PTFE-PTFE sliding, therefore without wear, form the second sealing at low pressure
- 1 O-Ring in NBR for sealing at very low pressure and vacuum
- all valves are tested according to a strict procedure covering severe inspections on the entire production.

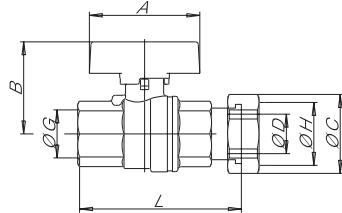
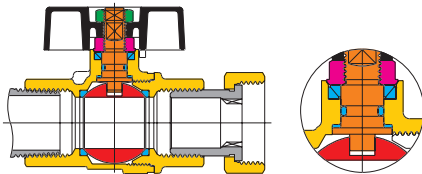
LIST OF COMPONENTS: description/materials/treatments

body and threaded end	yellow	hot stamped from bar	CW617N	UNI EN 12165
gland	violet	machined from bar	CW614N	UNI EN 12164
stem	orange	machined from bar	CW617N	UNI EN 12164
chromium pl. polished ball	red	machined from bar	CW617N	UNI EN 12164
nut	violet	hot stamped from bar	CW617N	UNI EN 12165
tail	yellow	hot stamped from bar	CW617N	UNI EN 12165
seals	blue	virgin PTFE		
stem packing o-ring	blue	NBR		DIN 3535
operation device	yellow	die-cast alum. alloy polyur. c.		
fixing nut	green	zinc plated steel		
surface treatment	—	brilliant nickel-plating		

GENERAL TABLE: valve dimensions per type and size

nominal diameter	10	15	15	20	25	32												
gas size in inch	3/8"x1/2"	1/2"x1/2"	1/2"x3/4"	3/4"x1"	1"x1" 1/4"	1" 1/4"x1" 1/2"												
Ø D bore mm	10	10	15	20	25	32												
A mm	47	47	47	56	56	130												
B mm	30	30	38	46	50	78												
Ø C mm	28	28	33	41	50	56												
Ø G	3/8"	1/2"	1/2"	3/4"	1"	1" 1/4												
Ø H	1/2"	1/2"	3/4"	1"	1" 1/4	1" 1/2												
female L mm	67	65	76	85	102	118												
male L mm	71	69	82	93	107	124												

VENUS with UNI hose union

**EN
331**

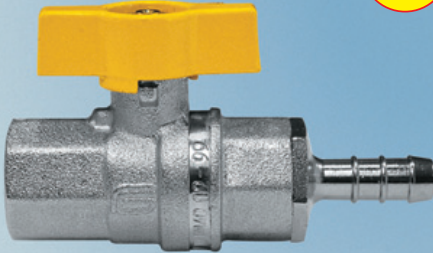

Art. 1021..XA f/hose union UNI 7141-8
Art. 1021..XB f/hose union UNI 7141-13

TECHNICAL FEATURES:

Temperature limits: for fluids from -15°C to +120°C (peak temperature +150°C)
for gas from -20°C to + 60°C

Pressure limits: for fluids 63 bar
for gas MOP 5

Operation devices:

Aluminium T-handle. Available colours: yellow.

Specific features:

The valve is available with hose union for gas tube according to UNI 7141-13 and with hose union for tube UNI 7141-8 which is particularly suitable for LPG.
The valve body derives from VENUS, certified according to EN 331:

- blow-out proof stem
- does not need any maintenance, is equipped with wrapping seats ensuring long life cycles
- an antifriction ring forms the first automatic sealing at high pressure
- two self-adjusting cone-shaped seals with PTFE-PTFE sliding, therefore without wear, form the second sealing at low pressure
- 1 O-Ring in NBR for sealing at very low pressure and vacuum
- all valves are tested according to a strict procedure covering severe inspections on the entire production.

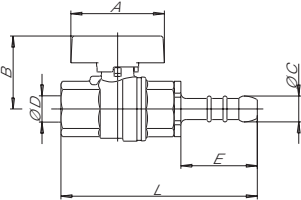
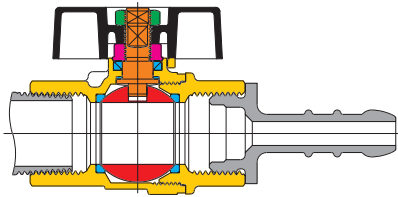

LIST OF COMPONENTS: description/materials/treatments

body and threaded end	yellow	hot stamped from bar	CW617N	UNI EN 12165
gland	violet	machined from bar	CW614N	UNI EN 12164
stem	orange	machined from bar	CW617N	UNI EN 12164
chromium pl. polished ball	red	machined from bar	CW617N	UNI EN 12164
hose union	violet	machined from bar	CW614N	UNI EN 12164
seals	blue	virgin PTFE		
operation device	yellow	die-cast alum. alloy polyur. c.		UNI 5076
fixing nut	green	zinc plated steel		
surface treatment	—	brilliant nickel-plating		

GENERAL TABLE: valve dimensions per type and size

nominal diameter	10	10	15	15									
gas size in inch	3/8"x8	3/8"x13	1/2"x8	1/2"x13									
Ø D bore mm	10	10	10	10									
A mm	47	47	47	47									
B mm	30	30	30	30									
Ø C mm	9,8	14	9,8	14									
E mm	29	44	29	44									
female L mm	79	94	83	98									
male L mm	83	98	87	102									

VENUS Angle

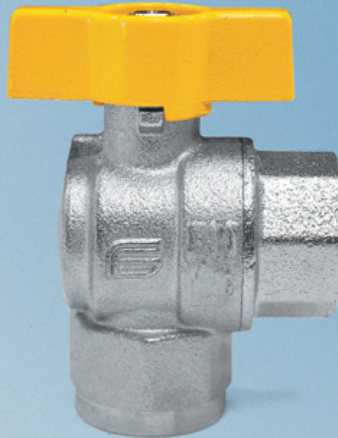

EN
331

Art. 1071 f/f with T-handle from 1/2" to 1"



Art. 1072 m/f with T-handle from 1/2" to 1"



Art. 1073 m/m with T-handle from 1/2" to 1"



Art. 1074 f/m with T-handle from 1/2" to 1"

VENUS Angle

TECHNICAL FEATURES:

Temperature limits:	for fluids	from -15°C to +100°C
	for gas	from -15°C to +60°C
Pressure limits:	for fluids	from 40 bar to 32 bar
	for gas	MOP 5

Application fields:

VENUS Angle series is particularly recommended in gas installations.

Threaded end connections:

- Standard female and male according to UNI ISO 7/1

Operation devices:

aluminium T-handle.

Available colours:

yellow.

SPECIFIC FEATURES:

The VENUS angle valve, with full bore, is heavy and well dimensioned. The VENUS stem packing guarantees a high reliability above all in applications with low and very low pressures, which are typical in domestic installations. The T-handle is in polyurethane coated aluminium and ensures solidity and durability.

- blow-out proof stem
- does not need any maintenance, is equipped with wrapping seats ensuring long life cycles
- an anti-friction ring forms the first automatic sealing at high pressure
- two self-adjusting cone-shaped seats, with PTFE-PTFE sliding, therefore without wear, form the second sealing at low pressure
- 1 O-Ring in NBR for sealing at very low pressure and vacuum
- All valves are tested according to a strict procedure covering severe inspections on the entire production.

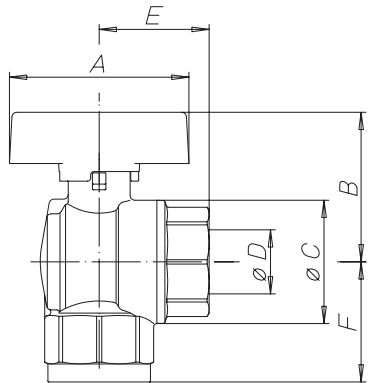
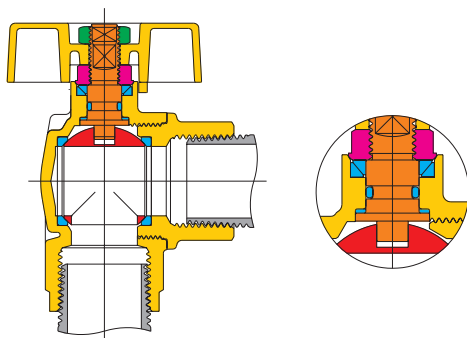
LIST OF COMPONENTS: description/materials/treatments

body and threaded end	yellow	hot stamped from bar	CW617N	UNI EN 12165
gland	violet	machined from bar	CW614N	UNI EN 12164
stem	orange	machined from bar	CW617N	UNI EN 12164
chromium pl. polished ball	red	machined from bar	CW617N	UNI EN 12164
seals	blue	virgin PTFE		
O-ring stem packing	blue	NBR		DIN 3535
operation device	yellow	die-cast alum. alloy polyur. c.		UNI 5076
fixing nut	green	zinc plated steel		
surface treatment	—	brilliant nickel-plating		

GENERAL TABLE: valve dimensions per type and size

nominal diameter	15	20	25
gas size in inch	1/2"	3/4"	1"
Ø D bore mm	15	20	25
A mm	47	56	56
B mm	32	38	46
Ø C mm	32	40	48
E mm	38	46	50
F mm	33	38	46
weight gr	212	365	566

PRESSURE/TEMPERATURE DIAGRAM

at each pressure level corresponds a specific admissible temperature level and viceversa

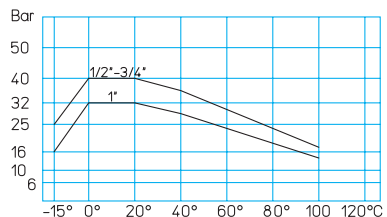

VENUS Angle with nut



Art. 1076..XG f/nut + tail

Art. 1079..XG m/nut + tail

TECHNICAL FEATURES:

Temperature limits: for fluids from -15°C to +100°C
for gas from -15°C to +60°C

Pressure limits: for fluids from 40 bar to 32 bar
for gas MOP 5

Operation devices:

Aluminium T-handle. Available colours: yellow.

SPECIFIC FEATURES:

The connections have sizes moved by one position. Nevertheless size 1/2" x 1/2" is also available. The valve body derives from VENUS Angle:

- blow-out proof stem
- does not need any maintenance, is equipped with wrapping seats ensuring long life cycles
- an antifriction ring forms the first automatic sealing at high pressure
- two self-adjusting cone-shaped seals with PTFE-PTFE sliding, therefore without wear, form the second sealing at low pressure
- all valves are tested according to a strict procedure covering severe inspections on the entire production.

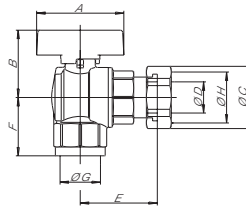
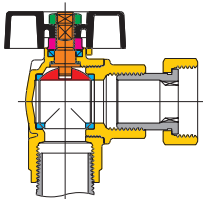
LIST OF COMPONENTS: description/materials/treatments

body and threaded end	yellow	hot stamped from bar	CW617N	UNI EN 12165
gland	violet	machined from bar	CW614N	UNI EN 12164
stem	orange	machined from bar	CW617N	UNI EN 12164
chromium pl. polished ball	red	machined from bar	CW617N	UNI EN 12164
nut	violet	hot stamped from bar	CW617N	UNI EN 12165
tail	yellow	hot stamped from bar	CW617N	UNI EN 12165
seals	blue	virgin PTFE		UNI 5076
operation device	yellow	die-cast alum. alloy polyur. c.		
fixing nut	green	zinc plated steel		
surface treatment	—	brilliant nickel-plating		

GENERAL TABLE: valve dimensions per type and size

nominal diameter	15	15																	
gas size in inch	1/2"x1/2"	1/2"x3/4"																	
Ø D bore mm	10	10																	
A mm	47	47																	
B mm	30	30																	
Ø C mm	25	33																	
Ø G	1/2"	1/2"																	
Ø H	1/2"	3/4"																	
E mm	42	46																	
female L mm	31	31																	
male L mm	28	28																	

VENUS Angle with UNI hose union



Art. 1076..XA f/hose union UNI 7141-8
Art. 1076..XB f/hose union UNI 7141-13

TECHNICAL FEATURES:

Temperature limits: for fluids from -15°C to +100°C
for gas from -15°C to +60°C

Pressure limits: for fluids from 40 bar to 32 bar
for gas MOP 5

Operation devices:

Aluminium T-handle. Available colours: yellow.

SPECIFIC FEATURES:

The valve is available with hose union for gas tube according to UNI 7141-13 and with hose union for tube according to UNI 7141-8 which is particularly suitable for LPG. The valve body derives from VENUS Angle:

- blow-out proof stem
- does not need any maintenance, is equipped with wrapping seats ensuring long life cycles
- an anti-friction ring forms the first automatic sealing at high pressure
- two self-adjusting cone-shaped seals with PTFE-PTFE sliding, therefore without wear, form the second sealing at low pressure
- all valves are tested according to a strict procedure covering severe inspections on the entire production.

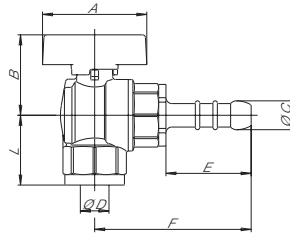
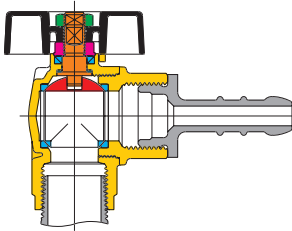
LIST OF COMPONENTS: description/materials/treatments

description	material	treatment	part number	UNI EN
body and threaded end	yellow	hot stamped from bar	CW617N	UNI EN 12165
gland	violet	machined from bar	CW614N	UNI EN 12164
stem	orange	machined from bar	CW617N	UNI EN 12164
chromium pl. polished ball	red	machined from bar	CW617N	UNI EN 12164
hose union	violet	machined from bar	CW614N	UNI EN 12164
seals	blue	virgin PTFE		
operation device	yellow	die-cast alum. alloy polyur. c.		UNI 5076
fixing nut	green	zinc plated steel		
surface treatment	—	brilliant nickel-plating		

GENERAL TABLE: valve dimensions per type and size

dimension	15	15								
nominal diameter	15	15								
gas size in inch	1/2"x8	1/2"x13								
Ø D bore mm	10	10								
A mm	47	47								
B mm	30	30								
Ø C mm	9,8	14								
E	29	44								
F	58	73								
female L mm	31	31								
male L mm	27	27								

MINERVA

EN
331

EN
1775



HTB
HIGH TEMPERATURE
BURSTING

Art. 1111 t/f with steel lever handle from 1/2" to 2"



Art. 1112 t/m with steel lever handle from 1/2" to 2"



Art. 1121 t/f with T-handle from 1/2" to 1"



Art. 1122 t/m with T-handle from 1/2" to 1"

MINERVA EN 331 - EN 1775 HTB

TECHNICAL FEATURES:

Temperature limits: for fluids from -15°C to +120°C
for gas from -20°C to +60°C

Pressure limits: for fluids 63 bar
for gas MOP 5

Application fields:

The MINERVA gas valve has been specifically developed for the gas installations after the meter, for a bigger safety and reliability into the house.

SPECIFIC FEATURES:

- MINERVA is a gas valve certified by DVGW - Germany, which guarantees the perfect agreement between the product and the regulations, according to EN 331 standards of '98, that establishes the constructive, dimensional and functional features of the gas valve in Europe, and according EN 1775 standards of 2000 (in addition to DIN 3537/1) that imposes the resistance of the gas plant to high temperatures in cases of fire - the HTB.

The valve, innovative for conception and realization, is tested and certified to resist at 650°C for one hour, the reasonable length of time for the assistance in case of fire. The normative establishes a length of 30 minutes, but the EFFEBI technology has allowed to double the required time. All the essential data of the valve (certifications, production date, ecc.) are indelibly engraved on the turned band directly on the body (EFFEBI patented system).

- blow-out proof stem
- does not need any maintenance, is equipped with wrapping seats ensuring long life cycles
- an antifriction ring forms the first automatic sealing at high pressure
- two self-adjusting cone-shaped seals, with PTFE-PTFE sliding, therefore without wear, form the second sealing at low pressure
- 1 O-Ring in NBR for sealing at very low pressure and vacuum
- all EFFEBI valves are tested according to a strict procedure covering severe inspections on the entire production.
- on request the valve is available with ATEX certificate

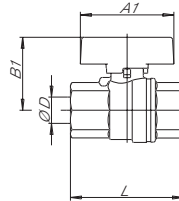
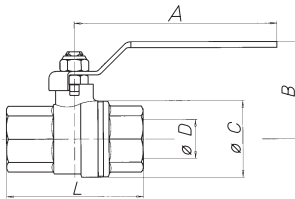

GENERAL TABLE: valve dimensions per type and size

nominal diameter	15	20	25	32	40	50							
gas size in inch	1/2"	3/4"	1"	1 1/4"	1 1/2"	2"							
Ø D passaggio mm	13/15	18/20	23/25	30/32	38/40	47,5/50							
A mm	85	105	105	130	130	165							
B mm	49	57	61	75	81	97							
A1	47	47	47	56	56	130							
B1	30	30	38	46	50	78							
Ø C mm	32	40	48	60	72	88							
emale	L mm	61	70	84	98	108	130						
female	weight gr	210	356	585	950	1400	2450						
male	L mm	67	78	89	104	114	136						
female	weight gr	220	380	600	980	1490	2520						

PRESSURE/TEMPERATURE DIAGRAM

at each pressure level corresponds a specific admissible temperature level and viceversa

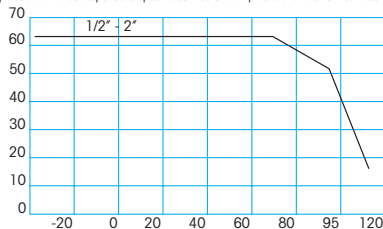

LOSS OF HEAD DIAGRAM:

the KV value is the port capacity causing a pressure drop of 1 bar.

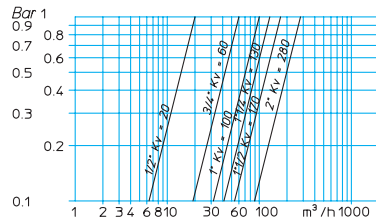

VENUS WITH NUT FOR GAS METERS



NEW

Art. 2162G424 male 1/2" ISO 228 / turnable nut 3/4"
Art. 2164G405 male 3/4" ISO 228 / turnable nut 3/4"

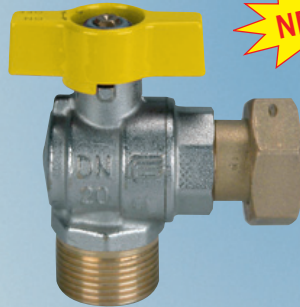

NEW

Art.2168G424 angle, male 1/2" ISO 228 / turnable nut 3/4"
Art. 2168G405 angle, male 3/4" ISO 228 / turnable nut 3/4"

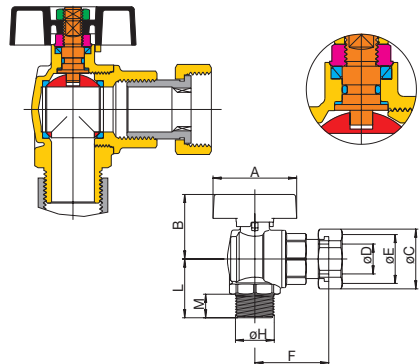
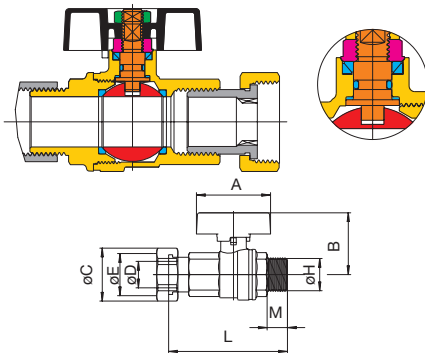
TECHNICAL FEATURES

Temperature limits: for fluids from -15°C to +120°C
Pressure limits: for fluids PN 40 for gas MOP 5

Operation devices:

Aluminium T-handle.
Available colours: yellow or red.

SPECIFIC FEATURES

Models: male/turnable nut for water meters with sealing hole on nut, 1,5 mm bore.

- blow-out proof stem
- Does not need any maintenance as it is equipped with wrapping seals ensuring long-life cycles.
- 1 antifriction ring forms the first automatic sealing at high pressure
- 2 PTFE cone-shaped sliding seals without wear form the second sealing at low pressure
- 1 NBR O-Ring for sealing at very low pressure and vacuum
- All valves are tested according to a strict procedure covering severe inspections on the entire production.
- For pressure and temperature table refer to Aster.

LIST OF COMPONENTS description/materials/treatments

Body and threaded end	yellow	hot-stamped from bar	CW617N	UNI EN 12165
Gland	violet	machined from bar	CW614N	UNI EN 12164
Stem	orange	machined from bar	CW614N	UNI EN 12164
Chromium-plated polished ball	red	machined from bar	CW614N	UNI EN 12164
Nut	yellow	hot-stamped from bar	CW617N	UNI EN 12165
Seats	blue	virgin PTFE	CW617N	UNI EN 12165
Stem o-ring	blue	NBR		
Operation device	black	die-cast aluminium alloy polyurethane c.		DIN 3535
Fixing screw	green	zinc-plated steel		UNI 5076
Surface treatment	--	brilliant nickel-plating		

GENERAL TABLE:

	STRAIGHT		ANGLE	
nominal diameter	15	20	15	20
gas size in inch	1/2" x 3/4"	3/4" x 3/4"	1/2" x 3/4"	3/4" x 3/4"
Ø D bore mm	15	15	15	15
A mm	47	47	47	47
B mm	37,5	37,5	37,5	37,5
Ø C mm	34	34	34	34
Ø E	3/4"	3/4"	3/4"	3/4"
F mm			42,3	42,3
Ø H	1/2"	3/4"	1/2"	3/4"
L mm	75,8	79,3	31,5	35
M	11,7	15,2	12	16

LPG

**NPT
THREAD**

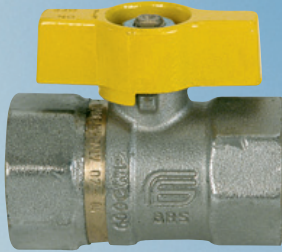

Art. 4097 F/F NPT Available range from 3/8" to 3/4"

TECHNICAL FEATURES:

Temperature limits: for fluids from -15°C to +100°C
for gas from -15°C to +60°C
Pressure limits: for fluids 40 bar
for gas MOP 10 (UL® and CSA® approved)

Application fields:

LPG valves are studied for Liquid Propane Gas applications, developed according to UL® and CSA® standard.

Threaded end connections:

3/8" - 1/2" - 3/4" Female NPT threads

Operation devices: yellow aluminium T-handle

Specific features:

- The LPG valve is compact, versatile and easy to install.
- The Female-Female type is threaded according to NPT standard, as requested by the most important LPG application
- Blow-out proof stem.
- It does not need maintenance, it is equipped with wrapping lateral seats ensuring long life cycles
- The stem package system is composed of 3 seals: two NBR o-ring seals for low pressure and a PTFE ring for high pressure.
- All EFFEBI valves are 100% tested according to a strict procedure covering severe inspections on the entire production.

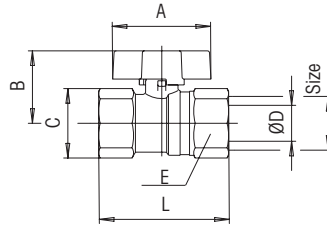
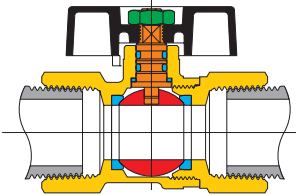

LIST OF COMPONENTS: description/materials/treatments

body and threaded end	yellow	hot stamped from bar	CW617N	UNI EN 12165
stem	orange	machined from bar	CW614N	UNI EN 12164
chromium pl. polished ball	red	machined from bar	CW617N	UNI EN 12164
seals	blue	Reinforced PTFE with glass fiber		
stem packing	blue	NBR		DIN 3535
operation device	black	die-cast alumin. alloy polyur. c.		UNI 5076
fixing nut	green	zinc plated steel		

GENERAL TABLE: valve dimensions per type and size

nominal diameter	10	15	20						
size	3/8" NPT	1/2" NPT	3/4" NPT						
Ø D bore mm	10	10	15						
A mm	47	47	47						
B mm	30,8	30,8	34,7						
Ø C mm	24	26,4	32,7						
E wrench size	21	25	31						
L mm	47	55,8	66,2						
weight gr	128	163	246						

LPG

**NPT
THREAD**

NEW



Art 4094 F/F NPT with sealed side tap. Available range from 3/8" to 3/4"

TECHNICAL FEATURES:

Temperature limits: for fluids from -15°C to +100°C
for gas from -15°C to +60°C

Pressure limits: for fluids 40 bar
for gas MOP 10 (UL® and CSA® approved)

Application fields:

LPG valves are studied for Liquid Propane Gas applications, developed according to UL® and CSA® standard.

Threaded end connections:

3/8" - 1/2" - 3/4" Female NPT threads

Operation devices: yellow aluminium T-handle

Specific features:

- The LPG valve is compact, versatile and easy to install.
- The Female-Female type is threaded according to NPT standard, as requested by the most important LPG application
- The valve is supplied with a sealed side tap allowing to run a leakage test or a pressure test, without dismantling the valve.
- Blow-out proof stem.
- It does not need maintenance, it is equipped with wrapping lateral seals that guarantee a high duration in the number of cycles.
- The stem package system is composed of 3 seals: two NBR o-ring seals for low pressure and a PTFE ring for high pressure.
- All EFFEBI valves are 100% tested according to a strict procedure covering severe inspections on the entire production.

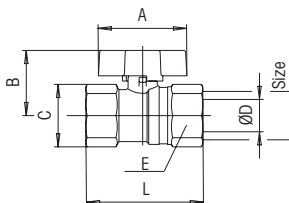
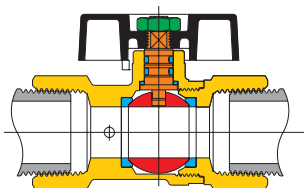

LIST OF COMPONENTS: description/materials/treatments

description	materials	treatments		
body and threaded end	yellow	hot stamped from bar	CW617N	UNI EN 12165
stem	orange	machined from bar	CW614N	UNI EN 12164
chromium pl. polished ball	red	machined from bar	CW617N	UNI EN 12164
seals	blue	Reinforced PTFE with glass fiber		
stem packing	blue	NBR		DIN 3535
operation device	black	die-cast alumin. alloy polyur. c.		UNI 5076
fixing nut	green	zinc plated steel		

GENERAL TABLE: valve dimensions per type and size

nominal diameter	10	15	20						
size	3/8" NPT	1/2" NPT	3/4" NPT						
Ø D bore mm	10	10	15						
A mm	47	47	47						
B mm	30,8	30,8	34,7						
C mm	24	26,4	32,7						
E wrench size	21	25	31						
L mm	52	62,3	69						
weight gr	147	182	271						

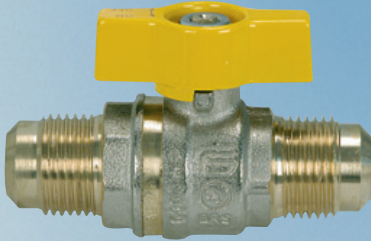
FLARE



Art. 4091 Flare/Flare SAE 45°. Available range from 3/8" to 5/8"

TECHNICAL FEATURES:

Temperature limits: for fluids from -15°C to +100°C
for gas from -15°C to +60°C

Pressure limits: for fluids from 40 bar to 32 bar
for gas MOP 10 (UL® and CSA® approved)

Application fields:

- FLARE is studied for Liquid Propane Gas applications, developed according to UL® and CSA® standards.

Threaded end connections:

3/8" SAE - 1/2" SAE - 5/8" SAE Flare - Flare threads

Operation devices: yellow aluminium T-handle

Specific features:

- The FLARE valve is compact, versatile and easy to install.
- With "flare" connection, the pipe does not need to be threaded
- Blow-out proof stem.
- It does not need maintenance, it is equipped with wrapping lateral seats ensuring long life cycles
- The stem package system is composed of 3 seals: two NBR o-ring seals for low pressure and a PTFE ring for high pressure.
- All EFFEBI valves are 100% tested according to a strict procedure covering severe inspections on the entire production.

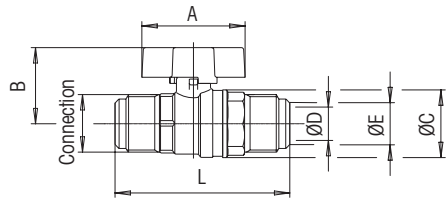
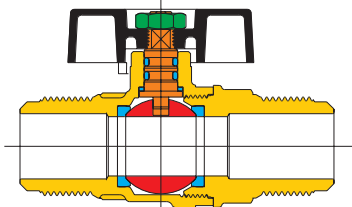

LIST OF COMPONENTS: description/materials/treatments

body and threaded end	yellow	hot stamped from bar	CW617N	UNI EN 12165
stem	orange	machined from bar	CW614N	UNI EN 12164
chromium pl. polished ball	red	machined from bar	CW617N	UNI EN 12164
seals	blue	Reinforced PTFE with glass fiber		
stem packing	blue	NBR		DIN 3535
operation device	black	die-cast alumin. alloy polyur. c.		UNI 5076
fixing nut	green	zinc plated steel		

GENERAL TABLE: valve dimensions per type and size

connection	3/8" SAE	1/2" SAE	5/8" SAE					
thread	5/8" UNF	3/4" UNF	7/8" UNF					
Ø D bore mm	7,15	10,3	12,7					
A mm	47	47	47					
B mm	30,8	30,8	34,7					
Ø C mm	24	24	31					
ØE inches	3/8"	1/2"	5/8"					
ØE mm	9,5	12,7	15,9					
L mm	65,5	72	80,3					
weight gr	151	167	254					

FLARE



Art 4095 Flare/Flare SAE 45° with sealed side top. Available range from 3/8" to 5/8"

TECHNICAL FEATURES:

Temperature limits: for fluids from -15°C to +100°C
for gas from -15°C to +60°C

Pressure limits: for fluids 40 bar
for gas MOP 10 (UL® and CSA® approved)

Application fields:

- FLARE is studied for Liquid Propane Gas applications, developed according to UL® and CSA® standards.

Threaded end connections:

3/8" SAE - 1/2" SAE - 5/8" SAE Flare - Flare threads

Operation devices: yellow aluminium T-handle

Specific features:

- The FLARE valve is compact, versatile and easy to install.
- With "flare" connection, the pipe does not need to be threaded
- The valve is supplied with a sealed side tap allowing to run a leakage test or a pressure test, without dismantling the valve.
- Blow-out proof stem.
- It does not need maintenance, it is equipped with wrapping lateral seats ensuring long life cycles.
- The stem package system is composed of 3 seals: two NBR o-ring seals for low pressure and a PTFE ring for high pressure.
- All EFFEBI valves are 100% tested according to a strict procedure covering severe inspections on the entire production.

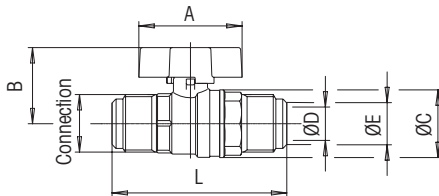
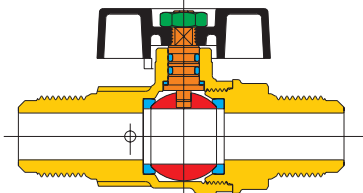

LIST OF COMPONENTS: description/materials/treatments

body and threaded end	yellow	hot stamped from bar	CW617N	UNI EN 12165
stem	orange	machined from bar	CW614N	UNI EN 12164
chromium pl. polished ball	red	machined from bar	CW617N	UNI EN 12164
seals	blue	Reinforced PTFE with glass fiber		
stem packing	blue	NBR		DIN 3535
operation device	black	die-cast alumin. alloy polyur. c.		UNI 5076
fixing nut	green	zinc plated steel		

GENERAL TABLE: valve dimensions per type and size

connection	3/8" SAE	1/2" SAE	5/8" SAE						
thread	5/8" UNF	3/4" UNF	7/8" UNF						
Ø D bore mm	7,15	10,3	12,7						
A mm	47	47	47						
B mm	30,8	30,8	34,7						
Ø C mm	24	24	31						
Ø E mm	9,5	12,7	15,9						
L mm	71	76,5	88,5						
weight gr	176	190	293						

KOMBI

**NPT
THREAD**

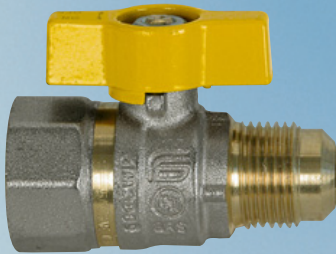

Art. 4092 - Art. 4093 Female NPT/SAE 45° copper end

TECHNICAL FEATURES:

Temperature limits: for fluids from -15°C to +100°C
for gas from -15°C to +60°C

Pressure limits: for fluids 40 bar
for gas MOP 10

Application fields:

• KOMBI valve is mainly studied for Liquid Propane Gas applications, developed according to UL® and CSA® standard.

Threaded end connections:

1/2" Female NPT – 3/8" SAE 45° copper end
1/2" Female NPT – 1/2" SAE 45° copper end
3/4" Female NPT – 5/8" SAE 45° copper end

Operation devices: yellow aluminium T-handle

Specific features:

- The KOMBI valve is compact, versatile and easy to install. It offers the possibility to combine two different connections without adding any fitting
- With "flare" connection, the pipe does not need to be threaded
- The Female connection is threaded according to NPT standard, as requested by the most important LPG applications
- Blow-out proof stem.
- It does not need maintenance, it is equipped with wrapping lateral seats ensuring long life cycles.
- The stem package system is composed of 3 seals: two NBR o-ring seals for low pressure and a PTFE ring for high pressure.
- All EFFEBI valves are 100% tested according to a strict procedure covering severe inspections on the entire production.

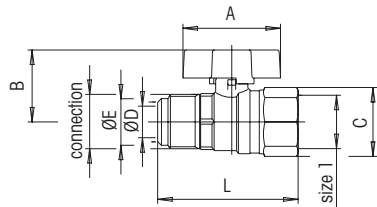
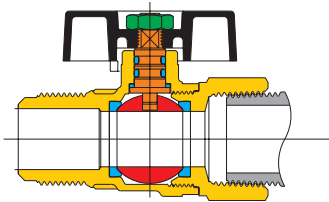
LIST OF COMPONENTS: description/materials/treatments

body and threaded end	yellow	hot stamped from bar	CW617N	UNI EN 12165
stem	orange	machined from bar	CW614N	UNI EN 12164
chromium pl. polished ball	red	machined from bar	CW617N	UNI EN 12164
seals	blue	Reinforced PTFE with glass fiber		
stem packing	blue	NBR		DIN 3535
operation device	black	die-cast alumin. alloy polyur. c.		UNI 5076
fixing nut	green	zinc plated steel		

GENERAL TABLE: valve dimensions per type and size

connection	3/8" SAE 45°	1/2" SAE 45°	5/8" SAE 45°						
thread	5/8" UNF	3/4" UNF	7/8" UNF						
size 1	1/2" NPT	1/2" NPT	3/4" NPT						
Ø D bore mm	7,15	10,3	12,7						
A mm	47	47	47						
B mm	30,8	30,8	34,7						
Ø C mm	26,4	26,4	32,7						
ØE mm	9,5	12,7	15,9						
L mm	59,2	61,3	68,7						
weight gr	159	157	234						

KOMBI W

ISO 7/1
THREAD



Art. 4949 (brass) Female ISO 7/1 Rp / Gas 60° copper end Art. 4950 (DZR) Female ISO 7/1 Rp / Gas 60° copper end

TECHNICAL FEATURES:

Temperature limits: for fluids from -15°C to +100°C
for gas from -15°C to +60°C

Pressure limits: for fluids 40 bar (W = PN 16)
MOP 10
for gas

Application fields:

• KOMBI valve is studied for Gas applications, and Water applications developed according to AGA® standard (Art 4949 and 4950) and Watermark® standard (Art 4950)

Threaded end connections:

Art 4949 - Art 4950

1/2" Female ISO 7/1 Rp – 1/2" Gas 60° copper end
3/4" Female ISO 7/1 Rp – 3/4" Gas 60° copper end

Operation devices: yellow aluminium T-handle (Art 4949)
green aluminium T-handle (Art 4950)

Specific features:

- The KOMBI valve is compact, versatile and easy to install. It offers the possibility to combine two different connections without adding any fitting
- With "flare" connection, the pipe does not need to be threaded
- Blow-out proof system.
- It does not need maintenance, it is equipped with wrapping lateral seats ensuring long life cycles.
- The stem package system is composed of 3 seals: two NBR o-ring seals for low pressure and a PTFE ring for high pressure.
- All EFFEBI valves are 100% tested according to a strict procedure covering severe inspections on the entire production.

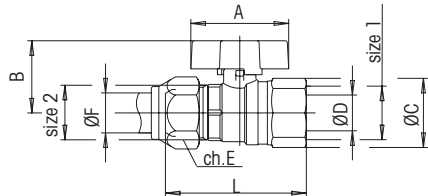
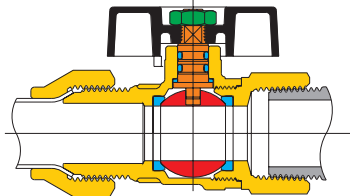

LIST OF COMPONENTS: description/materials/treatments			4949	4950	
body and threaded end	yellow	hot stamped from bar	CW617N	CW602N	UNI EN 12165
stem	orange	machined from bar	CW614N	CW602N	UNI EN 12164
chromium pl. polished ball	red	machined from bar	CW617N	CW602N	UNI EN 12164
seals	blue	Reinforced PTFE with glass fiber			
stem packing	blue	NBR			DIN 3535
operation device	black	die-cast alumin. alloy polyur. c.			UNI 5076
fixing nut	green	zinc plated steel			

GENERAL TABLE: valve dimensions per type and size									
size 1	1/2"Rp	3/4"Rp							
size 2	1/2" BSP 60°	3/4" BSP 60°							
Ø D bore mm	10	15							
A mm	47	47							
B mm	30,8	34,7							
Ø C mm	26,4	32,7							
E wrench size	24	30							
ØF inches	1/2"	3/4"							
L mm	63,1	70,2							
weight gr	193	300							

Copper-Copper (Cu_xCu)



Art. 4946 - Art. 4947 - Art. 4948

TECHNICAL FEATURES:

Temperature and pressure limits:
For gas: -15°C + 60°C MOP 10 (AGA approved)
For fluids: -15°C + 100°C 40 bar (**W** = PN 16)

Application fields:

- The COPPER-COPPER (Cu_xCu) valve is studied particularly for water and gas installations with copper pipes.

Specific features:

- The COPPER-COPPER (Cu_xCu) valve is compact, versatile and easy to install.
- With "flare" connection, the pipe does not need to be threaded.
- The sealing with the copper pipe is without olives, but is obtained introducing the pipe into the nuts and screwing these on the ends of the valve. The particular flare shape of the ends guarantees a perfect metallic sealing.
- Blow-out proof stem.
- Does not need any maintenance, is equipped with wrapping seats ensuring long life cycles.
- The stem packing is composed of 3 seals: two O-rings for low pressures and an antifriction ring in PTFE for high pressure.
- Art 4948 is manufactured in DZR copper alloy (**Watermark**® approved)
- All EFFEBI valves are tested according to a strict procedure covering severe inspections on the entire production.

Sizes and end-connections (BRASS):

- Art. 4946 3/8" - 9,5 copper 60°
1/2" - 13 copper 60°
3/4" - 19 copper 60°

Sizes and end-connections (BRASS):

- Art. 4947 3/8" UNF - 8 copper 45°
5/8" UNF - 9,5 copper 45°
3/4" UNF - 13 copper 45°

Sizes and end-connections (DZR):

- Art. 4948 1/2"-13 copper 60°
3/4"-19 copper 60°

Operation devices:

Yellow (BRASS) or green (DZR) aluminium T-handle

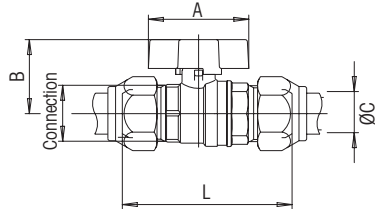
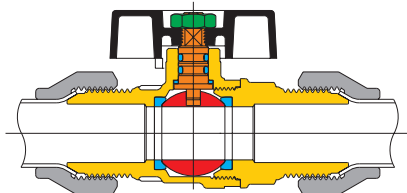

LIST OF COMPONENTS: description/materials/treatments

			4946/4947	4948	
body and threaded end	yellow	hot stamped from bar	CW617N	CW602N	UNI EN 12165
stem	orange	machined from bar	CW614N	CW602N	UNI EN 12164
chromium pl. polished ball	red	machined from bar	CW617N	CW602N	UNI EN 12164
seals	blue	Reinforced PTFE with glass fiber			
stem packing	blue	NBR			
operation device	black	die-cast alumin. alloy polyur. c.			UNI 5076
fixing nut	green	zinc plated steel			

GENERAL TABLE: valve dimensions per type and size Art. 4946

connection	3/8" BSP 60°	1/2" BSP 60°	3/4" BSP 60°
A mm	47	47	47
B mm	30,8	30,8	34,7
ØC inches	3/8"	1/2"	3/4"
ØC mm	9,5	13	19
L mm	67,5	71,3	79,4
weight gr	180	240	390

GENERAL TABLE: valve dimensions per type and size Art. 4947

connection	5/16" SAE 45°	3/8" SAE 45°	1/2" SAE 45°
A mm	47	47	47
B mm	30,8	30,8	30,8
ØC inches	5/16"	3/8"	1/2"
ØC mm	8	9,5	12,7
L mm	62,9	66,5	67,5
weight gr	173	176	203

GENERAL TABLE: valve dimensions per type and size Art. 4948

connection	1/2" BSP 60°	3/4" BSP 60°
A mm	47	47
B mm	30,8	34,7
ØC inches	1/2"	3/4"
ØC mm	13	19
L mm	71,3	79,4
weight gr	240	390

TRIFLUX



Art. 1100 3-way L-ported with lever in aluminium. Available range: from 1/4" to 2"
Art. 1120 3-way L-ported with lever in aluminium. Available range: from 1/4" to 2"

TECHNICAL FEATURES:

Temperature limits: for fluids from -15°C to +100°C
 Pressure limits: for fluids from 64 bar to 16 bar

Application fields:

TRIFLUX series is available both with L and T bore and allows to divert the flow in all directions including the inlet shut off, applicable to each of the three threaded ends. It is suggested for gas and water distribution, industrial and civil heating, water plants at medium pressure, hydraulics and pneumatics, non aggressive media and vacuum.

Threaded end connections:

- Standard Female to ISO 7/1 Rp

Operation devices:

Aluminium lever. Available colours: black.

SPECIFIC FEATURES:

- the TRIFLUX valve offers exceptional performances in the side and upper sealing in many applications
- the lever, thanks to an original device. Patented for the lever positioning all along 360°. Allows to perform all the operations with no need to be removed
- does not need any maintenance, is equipped with wrapping seats. According to a patented system. Ensuring long life cycles
- four self-adjusting cone-shaped seals, with PTFE-PTFE sliding, therefore without wear, form two sealings with automatic functioning
- an adjusting gland allows the sealing reset on the stem
- all valves are tested according to a strict procedure covering severe inspections on the entire production.

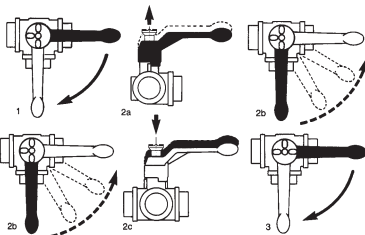
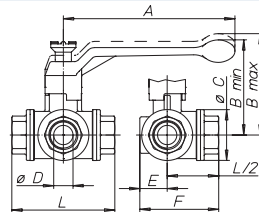
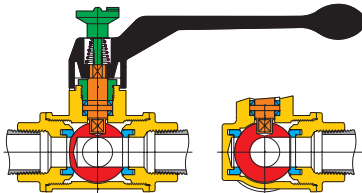

THE DIRECTION OF THE FLOW IS UNDERSTANDABLE FROM THE MARKING ON THE POSITION INDICATOR.

POSITION 1 and 3: active operations with rotation of the ball

POSITION 2a - 2b - 2c: passive operations with recovery of lever position with no ball rotation.

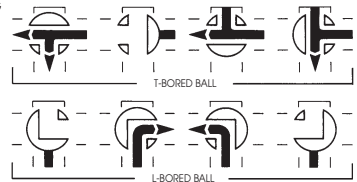
LIST OF COMPONENTS: description/materials/treatments

body and threaded end	yellow	hot stamped from bar	CW617N UNI EN 12165
gland	violet	machined from bar	CW614N UNI EN 12164
stem	orange	machined from bar	CW617N UNI EN 12164
chromium pl. polished ball	red	machined from bar	CW617N UNI EN 12164
seals	blue	virgin PTFE	
operation device	black	die-cast alumin. alloy polyur c.	UNI 5076
position indicator	orange		CW614N UNI EN 12164
spring + washer	violet	stainless steel	
screw	green	zinc plated steel	

GENERAL TABLE: valve dimensions per type and size

nominal diameter	8	10	15	20	25	32	40	50
gas size in inch	1/4"	3/8"	1/2"	3/4"	1"	1"1/4	1"1/2	2"
Ø D bore mm	10	13	13	18	23	29	35	44
A mm	130	130	130	160	160	195	195	235
B min mm	77	77	77	89	93	110	115	129
B max mm	85	85	85	98	102	121	125	141
Ø C mm	38	38	38	48	58	67	78	95
E mm	21	21	21	26	31	34	40	47
F mm	56	56	61	74	88	99	114	132
L mm	71	71	80	96	113	130	147	169
weight with L ball gr	679	643	637	1100	1710	2660	3710	5880
weight with T ball gr	677	639	632	1090	1695	2610	3660	5820

DELTA



Art. 1150 3-way L-port with lever in aluminium. Available range: from 1/4" to 2"

TECHNICAL FEATURES:

Temperature limits: for fluids from -10°C to +120°C
Pressure limits: for fluids 10 bar max

Application fields:

DELTA series is available with L bore and allows only the diversion of the flow without shutting off the flow with the typical operation of a standard two-way valve. It is suggested for gas and water distribution, industrial and civil heating, water plants at medium pressure, hydraulics and pneumatics, oil and petrochemical fields, non aggressive media.

Threaded end connections:

• Standard Female to ISO 7/1 Rp

Operation devices:

Aluminium lever. Available colours: black.

Specific features:

- the DELTA valve with full bore is a product of easy and safe utilization guaranteeing a long working endurance
- does not need any maintenance, is equipped with wrapping seats ensuring long life cycles
- four self-adjusting cone-shaped seals, with PTFE-PTFE sliding, therefore without wear, form two sealings with automatic functioning
- an adjusting gland allows the sealing reset on the stem
- all valves are tested according to a strict procedure covering severe inspections on the entire production.

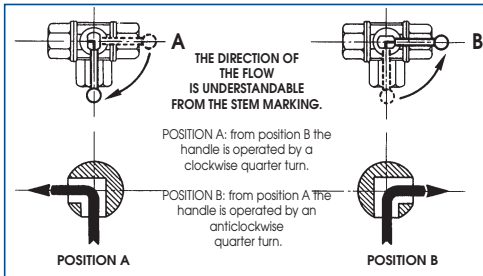
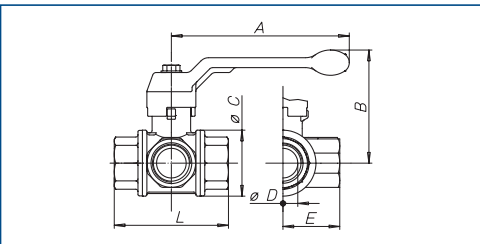
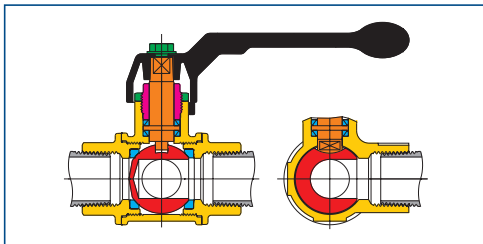
LOSS OF HEAD DIAGRAM:

the Kv value is the port capacity causing a pressure drop of 1 bar.

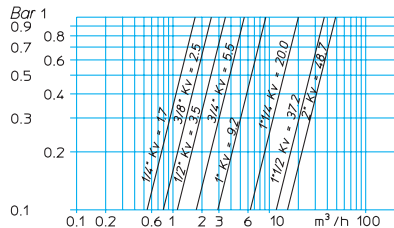
LIST OF COMPONENTS: description/materials/treatments

body and threaded end	yellow	hot stamped from bar	CW617N	UNI EN 12165
gland	violet	machined from bar	CW614N	UNI EN 12164
gland nut	green	machined from bar	CW614N	UNI EN 12164
stem	orange	machined from bar	CW617N	UNI EN 12164
chromium pl. polished ball	red	virgin PTFE	CW617N	UNI EN 12164
seals	blue	die-cast alumin. alloy polyur. c.		
operation device	black	stainless steel		UNI 5076
fixing screw	green	zinc plated steel		
surface treatment	-	brilliant nickel-plating		

GENERAL TABLE: valve dimensions per type and size

nominal diameter	8	10	15	20	25	32	40	50
gas size in inch	1/4"	3/8"	1/2"	3/4"	1"	1 1/4"	1 1/2"	2"
Ø D bore mm	10	10	14	19	24	30,5	38,5	48,5
A mm	100	100	100	120	120	150	150	175
B mm	61	61	64	76	80	98	104	119
Ø C mm	29	29	36	45	54	65	79	96
E mm	26	27	33	38	46	54	61	73
L mm	52	55	69	77	89	103	114	134
weight gr	295	270	410	680	1000	1740	2490	4020

OLYMPIC



Art. 1206 3-piece bolted and flanged with lever in aluminium. Available range: from DN 20 to DN 100

TECHNICAL FEATURES:

Temperature limits: for fluids from -15°C to +120°C
 Pressure limits: for fluids 16 bar for all the sizes available

Application fields:

OLYMPIC series is suggested in the case of frequent interchangeability of components, e.g. for maintenance reasons.
 It is usually employed for gas and water distribution, industrial and civil heating, water plants, hydraulics and pneumatics, oil and petrochemical fields, non aggressive media.

Connections:

• Standard Flanges to UNI 2240 and 2229 (sealing raised face PN 16)
 overall length to ISO 5752 (table 6 medium series PN 16)

Operation devices:

Aluminium lever. Available colours: black, yellow.

SPECIFIC FEATURES:

- the OLYMPIC valve with full bore, manufactured according to international standards, is of the type bolted with connection round flanges
- does not need any maintenance, is equipped with wrapping seats ensuring long life cycles
- four self-adjusting cone-shaped seals, with PTFE-PTFE sliding, therefore without wear, form two sealings with automatic functioning
- an adjusting gland allows the sealing reset on the stem
- all valves are tested according to a strict procedure covering severe inspections on the entire production.

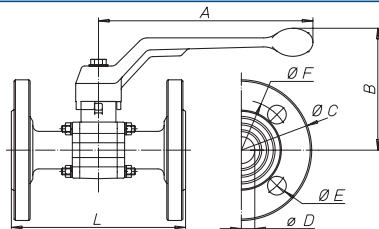
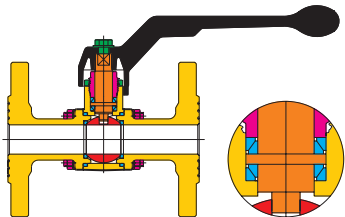
LIST OF COMPONENTS: description/materials/treatments

body and threaded end	yellow	hot stamped from bar	CW617N	UNI EN 12165
gland	violet	machined from bar	CW614N	UNI EN 12164
gland nut	green	machined from bar	CW614N	UNI EN 12164
stem	orange	machined from bar	CW617N	UNI EN 12164
chromium pl. polished ball	red	machined from bar	CW617N	UNI EN 12164
seals	blue	virgin PTFE		
O-Ring for flange sealing	blue	VITON		
operation device	black	die-cast alumin. alloy polyur c.		UNI 5076
tie rods, nuts and spring washers	violet	yellow zinc plated steel		
fixing screw	green	zinc plated steel		
surface treatment	—	brilliant nickel-plating		

GENERAL TABLE: valve dimensions per type and size

nominal diameter	20	25	32	40	50	65	80	100
size	DN 20	DN 25	DN 32	DN 40	DN 50	DN 65	DN 80	DN 100
Ø D bore mm	20	25	32	40	50	65	80	100
A mm	160	160	195	195	235	280	280	280
B mm	91	95	112	118	132	155	167	180
Ø C mm	105	115	140	150	165	185	200	220
Ø E mm	14	14	18	18	18	18	18	18
number of holes	4	4	4	4	4	4	8	8
Ø F mm	75	85	100	110	125	145	160	180
L mm	130	140	165	165	203	222	241	305
weight gr	2390	3050	4800	6140	8720	12800	16520	24500

LOSS OF HEAD DIAGRAM:

The Kv value is the port capacity causing a pressure drop of 1 bar.

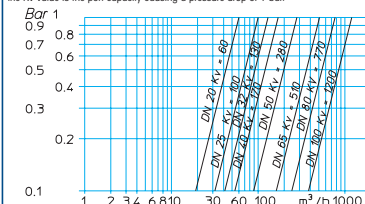

ROLLY



Art. 1216 with mobile flanges with lever in aluminium. Available range: from DN 15 to DN80

TECHNICAL FEATURES:

Temperature limits: for fluids from -20°C to +130°C
Pressure limits: for fluids 16 bar for all the sizes available

Application fields:

ROLLY series can be employed as an alternative to OLYMPIC. It is usually employed for gas and water distribution, industrial and civil heating, water plants, hydraulics and pneumatics, oil and petrochemical fields, non aggressive media.

Connections:

• Standard Flanges to UNI 2278 (sealing raised face PN16)

Operation devices:

Aluminium lever. Available colours: black

SPECIFIC FEATURES:

- the ROLLY valve, with full bore, employs the TOTAL ball valve as the basic component
- the flanges in steel are revolving and allow the positioning of the valve with respect to pipe axis
- does not need any maintenance, is equipped with wrapping seats ensuring long life cycles
- four self-adjusting cone-shaped seals, with PTFE-PTFE sliding, therefore without wear, form two sealings with automatic functioning
- an adjusting gland allows the sealing reset on the stem
- all valves are tested according to a strict procedure covering severe inspections on the entire production.

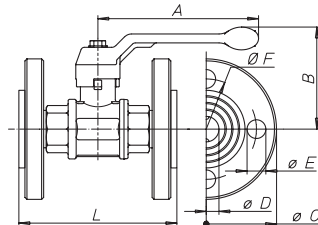
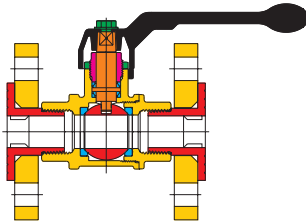
LIST OF COMPONENTS: description/materials/treatments

body and threaded end	yellow	hot stamped from bar	CW617N	UNI EN 12165
gland	violet	machined from bar	CW614N	UNI EN 12164
gland nut	green	machined from bar	CW614N	UNI EN 12164
stem	orange	machined from bar	CW617N	UNI EN 12164
chromium pl. polished ball	red	machined from bar	CW617N	UNI EN 12164
seals	blue	virgin PTFE		
O-ring	blue	NBR		DIN 3535
operation device	black	die-cast alumin. alloy polyur. c.		UNI 5076
turnable flanges	yellow	zinc plated steel		
threaded joint	red	hot stamped from bar	CW617N	UNI EN 12165
fixing screw	violet	zinc plated steel		
surface treatment	—	brilliant nickel-plating		

GENERAL TABLE: valve dimensions per type and size

nominal diameter	15	20	25	32	40	50	65	80
size	DN 15	DN 20	DN 25	DN 32	DN 40	DN 50	DN 65	DN 80
Ø D bore mm	15	20	25	32	40	50	65	80
A mm	100	160	160	195	195	235	280	280
B mm	64	92	96	113	120	135	155	167
Ø C mm	95	105	115	140	150	165	185	200
Ø E mm	14	14	14	18	18	18	18	18
number of holes	4	4	4	4	4	4	4	8
Ø F mm	65	75	85	100	110	125	145	160
L mm	105	118	135	149	161	181	209	238
weight gr	1635	2470	3280	5200	6700	9200	12550	17000

LOSS OF HEAD DIAGRAM:

the Kv value is the port capacity causing a pressure drop of 1 bar.

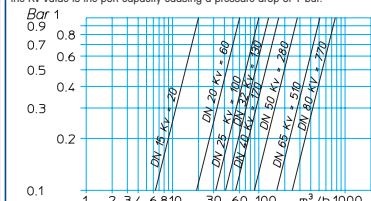

MINIBALL

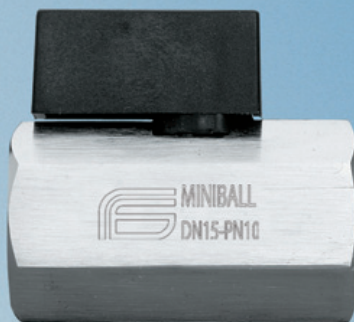

Art. 1501 F/F with little lever. Available range: from 1/8" to 1/2"

Art. 1502 M/F with little lever. Available range: from 1/8" to 1/2"

Art. 1503 M/F with little lever. Available range: from 1/8" to 1/2"



Art. 1511 F/F with driving screw from 1/8" to 1/2"

Art. 1512 M/F with driving screw from 1/8" to 1/2"

Art. 1513 M/M with driving screw from 1/8" to 1/2"

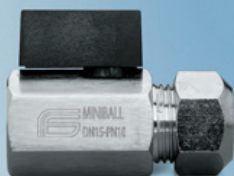

Art. 1521 C/F with little lever from 3/8" to 1/2"

Art. 1522 C/M with little lever from 3/8" to 1/2"

Art. 1523 C/C with little lever from 3/8" to 1/2"



Art. 1531 C/F with driving screw from 3/8" to 1/2"

Art. 1532 C/M with driving screw from 3/8" to 1/2"

Art. 1533 C/C with driving screw from 3/8" to 1/2"



Art. 1571 F/H with little lever from 1/8" to 1/2"

Art. 1572 M/H with little lever from 1/8" to 1/2"

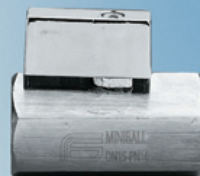

Art. 1591 F/F with little lever chromium plated from 1/8" to 1/2"

Art. 1592 M/F with little lever chromium plated from 1/8" to 1/2"

Art. 1593 M/M with little lever chromium plated from 1/8" to 1/2"

MINIBALL

TECHNICAL FEATURES:

Temperature limits: for fluids from -10°C to +90°C
Pressure limits: for fluids 10 bar max.

Application fields: MINIBALL series is mainly employed in combination with water exposed pipes, sanitation plants, civil heating, compressed air, tank discharge

Threaded end connections:

- Standard
- Female and male to ISO 228/1.

On request: Female and male ISO 7/1.

Operation devices: Glass filled nylon little lever chromium plated little lever, driving screw.
Available colours: black.

SPECIFIC FEATURES:

- the MINIBALL valve, with reduced bore, covers a wide range allowing considerable applications, particularly where space is reduced
- all valves are tested according to a strict procedure covering severe inspections on the entire production.

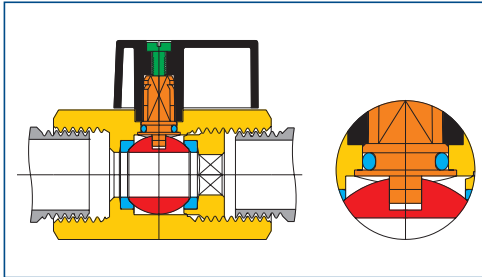

LOSS OF HEAD DIAGRAM:

the Kv value is the port capacity causing a pressure drop of 1 bar.

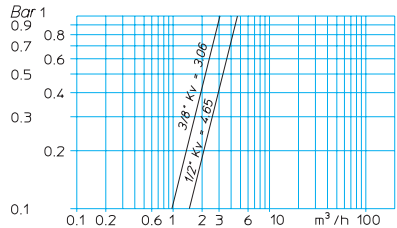

LIST OF COMPONENTS: description/materials/treatments

body and threaded end	yellow	machined from bar	CW617N	UNI EN 12164
stem	orange	machined from bar	CW617N	UNI EN 12164
chromium pl. polished ball	red	machined from bar	CW617N	UNI EN 12164
seals	blue	virgin PTFE		
stem packing	blue	O-ring		DIN 3535
operation device	black	glass filled nylon		
hose union	-	machined from bar	CW617N	UNI EN 12164
elastic pin	-	zinc plated steel		
nut for copper/copper version	-	machined from bar	CW614N	UNI EN 12164
olive for copper/copper version	-	virgin PTFE		
fixing screw	green	zinc plated steel		
surface treatment	-	brilliant nickel-plating		

GENERAL TABLE: valve dimensions per type and size

Size	bore	Weight														
		A	B	C	E	ch F	G	L	M	N	art.	art.	art.	art.	art.	
gas	Ø D	mm	mm	mm	mm	mm	mm	mm	mm	mm	1501	1502	1503	1511	1512	1513
1/8"	5,5	19	19	22	9	19	15	36	17	48	78	63	73	78	58	72
1/4"	5,5	19	19	22	9	19	15	36	17	48	71	61	77	70	61	74
3/8"	8,0	19	21	23	9	21	17	41	20	53	86	83	104	81	80	99
1/2"	10,0	22	25	30	11	25	19	48	23	62	137	130	169	133	126	165

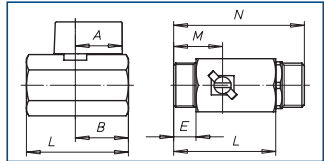

GENERAL TABLE: valve dimensions per type and size

Size	tube bore	Weight																	
		A	B	C	E	ch F	G	ch H	I	L1	L2	L3	art.	art.	art.	art.	art.		
gas	copper	Ø D	mm	mm	mm	mm	mm	mm	mm	mm	mm	mm	mm	mm	mm	mm	mm	mm	
3/8"	x 10	8	19	21	23	9	21	17	19	40	49	61	68	97	118	132	93	117	130
3/8"	x 12	8	19	21	23	9	21	17	19	41	50	62	70	93	116	127	90	109	124
1/2"	x 12	10	22	25	30	11	25	19	24	48	57	71	80	162	199	231	159	194	227
1/2"	x 14	10	22	25	30	11	25	19	24	49	58	72	82	188	195	223	154	192	215

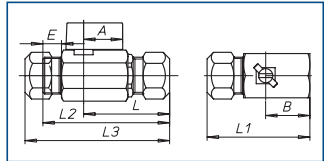

GENERAL TABLE: valve dimensions per type and size

Size	bore	Weight											
		A	B	C	E	ch F	G	H	Ø I	L	art.	art.	
gas	Ø D	mm	mm	mm	mm	mm	mm	mm	mm	mm	mm	mm	mm
1/8"	5,5	19	19	22	9	19	36	27	10,5	63	91	76	
1/4"	5,5	19	19	23	9	19	36	29	10,5	65	87	79	
3/8"	8,0	19	21	24	9	21	41	29	14,0	70	112	110	
1/2"	10,0	22	25	30	11	25	48	30	14,0	78	177	170	

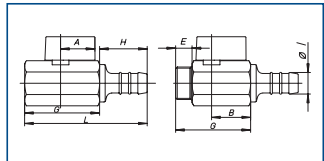

INCAS K



Art. 1600 for wall embedding 1/1 with chromium plated knob. Available range: from 1/2" to 1"



Art. 1605 for wall embedding 1/1 with chromium plated lever. Available range: from 1/2" to 1"



Art. 1610 for wall embedding 1/1 with chromium plated blind cap. Available range: from 1/2" to 1"

TECHNICAL FEATURES:

Temperature limits: for fluids from -15°C to +100°C
Pressure limits: for fluids 80 bar

Application fields:

INCAS K series is suitable for civil sanitation plants where the ball valve needs to be embedded in the wall

Threaded end connections:

- Standard. Female to ISO 228/1

Operation devices:

brilliant chromium plated knob or lever with rosette or cap with operation key

SPECIFIC FEATURES:

- the INCAS K valve, with full bore according to international standards, is suitable for wall embedding in water, heating and sanitation plants.. Structurally it derives from the KOSMOS series, with the same main features.
- does not need any maintenance, is equipped with wrapping seats ensuring long life cycles
- at disposal also extension sets to lengthen the distance between valve and operation devices up to 20 mm
- all valves are tested according to a strict procedure covering severe inspections on the entire production.

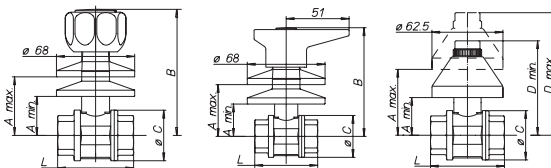
PRESSURE/TEMPERATURE DIAGRAM

at each pressure level corresponds a specific admissible temperature level and viceversa

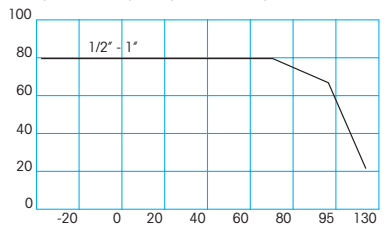
LIST OF COMPONENTS: description/materials/treatments

body and threaded end	hot stamped from bar	CW617N	UNI EN 12165
gland	machined from bar	CW614N	UNI EN 12164
stem	machined from bar	CW617N	UNI EN 12164
chromium pl. pol. ball	machined from bar	CW617N	UNI EN 12164
seals	virgin	PTFE	
stem packing	o-ring		DIN 3535
operation device	nickel-chrom. pl.	brass	CW614N UNI EN 12164 CW617N UNI EN 12165
fixing screw	zinc-plated steel		
surface treatment	brilliant	nickel-plating	

GENERAL TABLE: valve dimensions per type and size

nominal diameter	15	20	25
gas size in inch	1/2"	3/4"	1"
Ø C bore mm	15	20	25
A min/max mm	28/52	32/55	36/59
B mm	104	108	112
Ø C mm	35	43	52
D min/max mm	78/102	82/105	86/109
L mm	56	65	76
Art. 1600 weight gr	552	707	953
Art. 1605 weight gr	537	692	938
Art. 1610 weight gr	398	559	802

INCAS M



Art. 1620 for wall embedding 1/1" with chromium plated knob. Available range: from 1/2" to 1"



Art. 1625 for wall embedding 1/1" with chromium plated lever. Available range: from 1/2" to 1"



Art. 1630 for wall embedding 1/1" with chromium plated blind cap. Available range: from 1/2" to 1"

TECHNICAL FEATURES:

Temperature limits: for fluids from -15°C to +100°C
Pressure limits: for fluids 63 bar

Application fields:

INCAS M series is suitable for civil sanitation plants where the ball valve needs to be embedded in the wall

Threaded end connections:

- Standard Female to ISO 228/1

Operation devices:

brilliant chromium plated knob or lever with rosette or cap with operation key

SPECIFIC FEATURES:

- the INCAS M valve, with full bore according to international standards, is suitable for wall embedding in water, heating and sanitation plants. Structurally it derives from the MERCURY series, with the same main features.
- does not need any maintenance, is equipped with wrapping seats ensuring long life cycles
- at disposal also extension sets to lengthen the distance between valve and operation devices up to 20 mm
- all valves are tested according to a strict procedure covering severe inspections on the entire production.

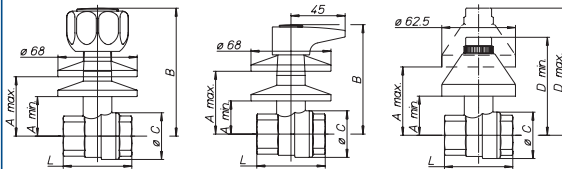

PRESSURE/TEMPERATURE DIAGRAM

of each pressure level corresponds a specific admissible temperature level and viceversa

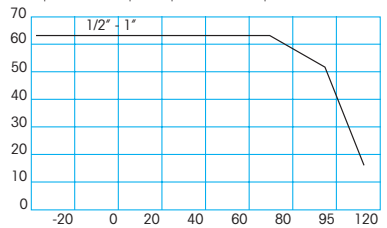

LIST OF COMPONENTS: description/materials/treatments

body and threaded end	hot stamped from bar	CW617N	UNI EN 12165
gland	machined from bar	CW614N	UNI EN 12164
stem	machined from bar	CW617N	UNI EN 12164
chromium pl. pol. ball	machined from bar	CW617N	UNI EN 12164
seals	virgin PTFE		
stem packing	o-ring		DIN 3535
operation device	nickel-chrom. pl. brass	CW614N UNI EN 12164	CW617N UNI EN 12165
fixing screw	zinc-plated steel		
surface treatment	brilliant nickel-plating		

GENERAL TABLE: valve dimensions per type and size

nominal diameter	15	20	25
gas size in inch	1/2"	3/4"	1"
Ø D bore mm	15	20	25
A min/max mm	28/152	32/57	36/60
B mm	103	107	111
Ø C mm	32	40	48
D min/max mm	78/102	82/105	86/103
L mm	50	58	69
Art. 1620 weight gr	478	610	783
Art. 1625 weight gr	451	583	756
Art. 1630 weight gr	337	466	642

INCAS EXTRA



For wall embedding
Extractable

Not necessary to break
the wall to do maintenance

Art. 1670 Wall embedding ball valve with extractable ball. Available range: 1/2" and 3/4"



Art. 7130 Chromium plated knob for INCAS EXTRA



Art. 7135 Chromium plated lever



Art. 7140 Chromium plated blind cap



Art. 7170 Knob/lever extension Kit



Art. 7200 Stem-ball-seats Kit



Art. 7180 Chromium plated cap extension Kit

INCAS EXTRA

TECHNICAL FEATURES:

 Temperature limits: for fluids from -20°C to +100°C
 Pressure limits: for fluids PN 16

Application fields:

INCAS EXTRA series is suitable for heating and sanitation wall embedded installations

Threaded end connections:

- Standard Female to ISO 7/1 Rp

Operation devices:

knob, lever handle or cap

SPECIFIC FEATURES:

- the INCAS EXTRA valve, with full bore, has been designed to offer the possibility to replace one or more sealing components if necessary, without replacing the complete ball valve
- Safety: the valve is designed to cope with the usual pressures of heating installations up to 100°C
- Endurance: the ball rotates perfectly supported on its axis, in order to avoid any forcing on the seals and consequently guarantees long life cycles with high safety margins
- at disposal also extension sets to lengthen the distance between valve and accessories up to 20 mm
- for loss of head diagram please refer to TOTAL series
- all valves are tested according to a strict procedure covering severe inspections on the entire production.

LIST OF COMPONENTS: description/materials/treatments

body	hot stamped from bar	CW617N	UNI EN 12165
gland	machined from bar	CW617N	UNI EN 12165
stem	machined from bar	CW617N	UNI EN 12164
nickel-chrom. pl. ball	machined from bar	CW617N	UNI EN 12164
seals	virgin PTFE		
stem packing	NBR O-ring		DIN 3535
operation devices	nickel-chromium plated brass	CW617N	UNI EN 12165
fixing screw	zinc plated steel		
washer	stainless steel AISI 304		

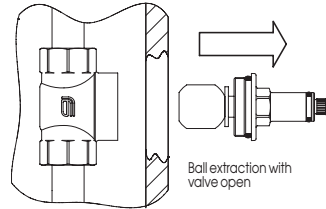
VALVE MAINTENANCE SCHEME

Ball extraction with valve open

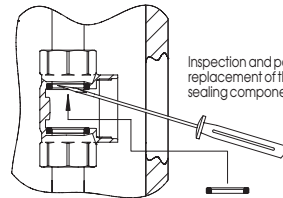

Inspection and possible replacement of the sealing components

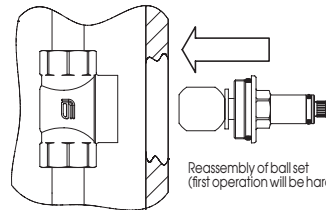

Reassembly of ball set (first operation will be harder)

INCAS EXTRA with knob

Size	DN	A	B
1/2"	15	28 - 50	103
3/4"	20	31 - 53	106
1"	25	34 - 56	109

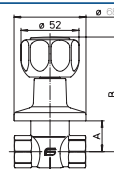
INCAS EXTRA with lever

Size	DN	A	B
1/2"	15	28 - 50	104
3/4"	20	31 - 53	107
1"	25	34 - 56	110

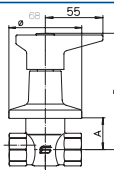
INCAS EXTRA with cap

Size	DN	A	B
1/2"	15	30 - 52	80 - 102
3/4"	20	33 - 55	83 - 105
1"	25	34 - 56	86 - 108

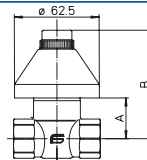

MANIFOLD K

TECHNICAL FEATURES:

 Temperature limits: for fluids from -20°C to +130°C
 Pressure limits: for fluids 80 bar

Application fields:

MANIFOLD K is recommended in heating installations for manifold purposes

Threaded end connections:

- Standard Female to ISO 228/1

Operation devices:

Aluminium T-handle Available colours: black, red and blue.

SPECIFIC FEATURES:

- the MANIFOLD K valve is supplied with one end female gas threaded and the other end with nut and tail where the metal sealing is supported by an O-ring. It is full bore according to international standards and has the same features of KOSMOS series from which it derives.
- does not need any maintenance, is equipped with wrapping seats ensuring long life cycles
- all valves are tested according to a strict procedure covering severe inspections on the entire production.

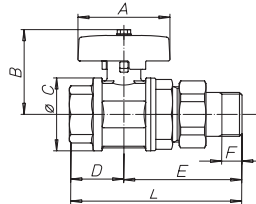
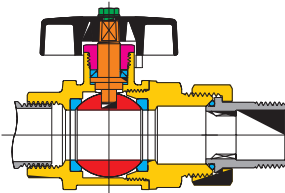
Art. 2027 F/Nut+tail with T-handle. Available range: from 1/2" to 1"

LIST OF COMPONENTS: description/materials/treatments

body and threaded end	yellow	hot stamped from bar	CW617N	UNI EN 12165
nut and tail	yellow	hot stamped from bar	CW617N	UNI EN 12165
gland	violet	machined from bar	CW614N	UNI EN 12164
stem	orange	machined from bar	CW617N	UNI EN 12164
chromium pl. polished ball	red	machined from bar	CW617N	UNI EN 12164
seals	blue	Virgin PTFE		
tail seal	blue	NBR O-ring		DIN 3535
operation device	black	die-cast alumin. alloy polyur. C.		UNI 5076
fixing screw	green	zinc-plated steel		
surface treatment	—	brilliant nickel-plating		

GENERAL TABLE: valve dimensions per type and size

nominal diameter	15	20	25						
gas size in inch	1/2"	3/4"	1"						
Ø bore mm	15	20	25						
A mm	55	55	70						
B mm	46	51	61						
Ø C mm	33	40	49						
D mm	28	33	38						
E mm	65	72	85						
F mm	10	12	14						
L mm	93	105	122						
weight gr	392	598	871						

MANIFOLD M



Art. 2037 F/Nut+tail with T-handle. Available range: from 1/2" to 2"

TECHNICAL FEATURES:

Temperature limits: for fluids from -15°C to +120°C
Pressure limits: for fluids 63 bar

MANIFOLD M series is recommended in heating installations for manifold purposes

Threaded end connections:

- Standard Female to ISO 228/1

Operation devices:

Aluminium T-handle Available colours: black, red and blue.

SPECIFIC FEATURES:

- the MANIFOLD M valve is supplied with one end female gas threaded and the other end with nut and tail where the metal sealing is supported by an O-ring. It is full bore according to international standards and has the same features of MERCURY series from which it derives.
- does not need any maintenance, is equipped with wrapping seats ensuring long life cycles
- all valves are tested according to a strict procedure covering severe inspections on the entire production.

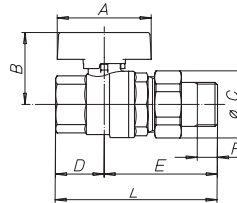
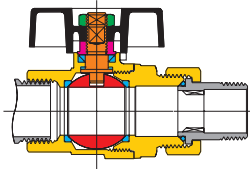
LIST OF COMPONENTS: description/materials/treatments

body and threaded end	yellow	hot stamped from bar	CW617N	UNI EN 12165
nut and tail	yellow	hot stamped from bar	CW617N	UNI EN 12165
gland	violet	machined from bar	CW614N	UNI EN 12164
stem	orange	machined from bar	CW617N	UNI EN 12164
chromium pl. polished ball	red	machined from bar	CW617N	UNI EN 12164
seals	blue	Virgin PTFE		
	blue			DIN 3535
tail seal	blue	NBR O-ring		DIN 3535
operation device	black	die-cast alumin. alloy polyur. C.		UNI 5076
fixing screw	green	zinc-plated steel		
surface treatment	—	brilliant nickel-plating		

GENERAL TABLE: valve dimensions per type and size

nominal diameter	15	20	25	32	40	50				
gas size in inch	1/2"	3/4"	1"	1 1/4"	1 1/2"	2"				
Ø bore mm	15	20	25	32	40	50				
A mm	47	56	56	130	130	165				
B mm	33	43	47	70	76	92				
Ø C mm	33	41	49	41	47	55				
D mm	25	29	34	55	69	90				
E mm	59	68	78	74	76	77				
F mm	10	12	14	15	16	18				
L mm	84	98	112	129	145	167				
weight gr	276	472	740	1195	1985	3390				

MANIFOLD A



TECHNICAL FEATURES:

Temperature limits: for fluids from -15°C to +100°C
Pressure limits: for fluids 40 bar

Application fields:

is recommended in heating installations for manifold sets.

Threaded end connections:

- standard female to ISO 228/1

Operation devices: aluminium T-handle. Available colours: black, red, blue.

SPECIFIC FEATURES:

- the MANIFOLD A valve is supplied with one end female gas threaded and the other end with nut and tail where the metal sealing is supported by an O-ring. It is full bore according to international standards and has the same features of ASTER series from which it derives.
- does not need any maintenance, is equipped with wrapping seats ensuring long life cycles.
- all valves are tested according to a strict procedure covering severe inspections on the entire production.

Art. 2047 F/Nut+tail with T-handle. Available range: from 1/2" to 1"

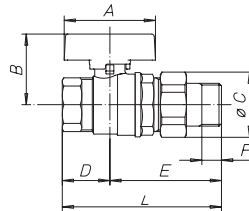
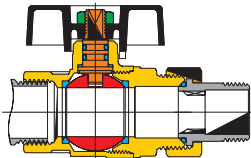

LIST OF COMPONENTS: description/materials/treatments

body and threaded end	yellow	hot stamped from bar	CW617N	UNI EN 12165
nut and tail	yellow	hot stamped from bar	CW617N	UNI EN 12165
stem	orange	machined from bar	CW617N	UNI EN 12164
chromium pl. polished ball	red	machined from bar	CW617N	UNI EN 12164
seals	blue	Virgin PTFE		
stem packing	blue	NBR O-ring		DIN 3535
tail seal	blue	NBR O-ring		DIN 3535
operation device	black	die-cast alumin. alloy polyur. C.		UNI 5076
fixing nut	green	zinc-plated steel		
surface treatment	—	brilliant nickel-plating		

GENERAL TABLE: valve dimensions per type and size

nominal diameter	15	20	25							
gas size in inch	1/2"	3/4"	1"							
Ø bore mm	15	20	25							
A mm	47	56	56							
B mm	35	42	47							
Ø C mm	33	40	49							
D mm	25	33	35							
E mm	59	65	77							
F mm	10	12	14							
L mm	84	98	112							
weight gr	256	438	694							

MANIFOLD Angle



TECHNICAL FEATURES:

Temperature limits: for fluids from -15°C to +120°C
Pressure limits: for fluids from 50 bar to 32 bar

Application fields:

The valve is recommended for heating installations with manifold sets.

Threaded end connections:

- Standard female to ISO 7/1Rp

Operation devices:

aluminium T-handle. Available colours: black, red, blue.

SPECIFIC FEATURES:

- the MANIFOLD RIGHT ANGLE series, is supplied with threaded female end connection in the lower part and tail end connection with metal seal supported by an O-ring. It is full bore according to international standards and has the same features of VENUS ANGLE series from which it derives.
- is perfectly air bubble tight.
- does not need any maintenance and is equipped with wrapping seats ensuring long life cycles.
- all valves are tested according to a strict procedure covering severe inspections on the entire production.

Art. 2077 F/Nut+tail with T-handle. Available range: from 1/2" to 1"

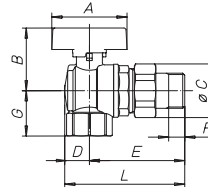
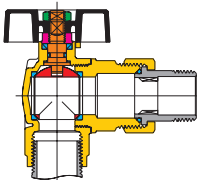

LIST OF COMPONENTS: description/materials/treatments

body and threaded end	yellow	hot stamped from bar	CW617N	UNI EN 12165
nut and tail	yellow	hot stamped from bar	CW617N	UNI EN 12165
gland	violet	machined from bar	CW614N	UNI EN 12164
stem	orange	machined from bar	CW617N	UNI EN 12164
chromium pl. polished ball	red	machined from bar	CW617N	UNI EN 12164
seals	blue	Virgin PTFE		
stem O-ring	blue	NBR O-ring		DIN 3535
tail seal	blue	NBR O-ring		DIN 3535
operation device	black	die-cast alumin. alloy polyur. C.		UNI 5076
fixing screw	green	zinc-plated steel		
surface treatment	—	brilliant nickel-plating		

GENERAL TABLE: valve dimensions per type and size

nominal diameter	15	20	25																
gas size in inch	1/2"	3/4"	1"																
Ø bore mm	15	20	25																
A mm	47	56	56																
B mm	38	46	50																
Ø C mm	33	40	49																
D mm	16	20	24																
E mm	60	70	82																
F mm	10	12	14																
G mm	27	32	38																
L mm	76	90	106																
weight gr	288	481	759																

EXTENSION



NEW

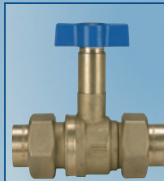

Art. 2170 F/F with lever in aluminium. Available range: from 1/2" to 2" **Art. 2185** Available range 3/4" and 1"

TECHNICAL FEATURES:

Temperature limits: For fluids: -15°C +100°C
Pressure limits: For fluids: PN 40 For gas: MOP 5

Application fields:

- The ball valve EXTENSION is recommended for central heating or cooling systems that need insulation.

Specific features:

- The full bore valve EXTENSION is an extremely rugged product.
- The extension is fixed and it does not swing during operation as it is an integral part of the body. In this way you can avoid that, as it can happen with classical aluminium extensions, insulation moves during opening and closing operation of the valve. You can also avoid condensate between the body of the valve and the extension.
- The opening and closing brackets of 90° are inside the valve. This feature allows the valve to be manoeuvred by a spanner if you need to dismantle the handle. During this operation, be sure that the ball is in the right position.
- It does not need maintenance, it is equipped with wrapping lateral seats that guarantee a high duration in number of cycles.
- The stem package system is made up of 3 NBR o-ring.
- All EFFEBI valves are 100% tested according to a strict procedure covering severe inspections on the entire production.
- Art.4790 has been developed for installations with welding end nipples.

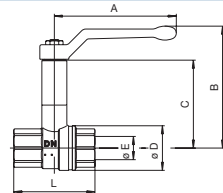
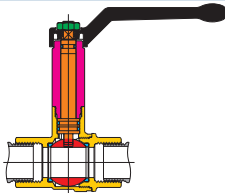

LIST OF COMPONENTS: description/materials/treatments

body and threaded end	yellow	hot stamped from bar	CW617N	UNI EN 12165
stem	orange	machined from bar	CW617N	UNI EN 12164
chromium pl. polished ball	red	machined from bar	CW617N	UNI EN 12164
seals	blue	Virgin PTFE		
stem o-ring	blue	EPDM		
upper stem o-ring	blue	NBR		DIN 3535
extension and gland	violet	hot stamped from bar	CW617N	UNI EN 12165
operation device	black	die-cast alumin. alloy polyur. C.		UNI 5076
fixing nut	green	zinc-plated steel		
external treatment	—	brilliant nickel-plating		

GENERAL TABLE: valve dimensions per type and size

nominal diameter	15	20	25	32	40	50									
gas size in inch	1/2"	3/4"	1"	1" 1/4	1" 1/2	2"									
Ø E bore mm	15	20	25	32	40	50									
A mm	85	105	105	130	130	165									
B mm	95	100	104	114	120	127									
C mm	68	71	75	79	85	85									
Ø D	31	38.5	47	57.5	70	88.5									
L mm	61	69.5	83.5	97	108	130									
weight gr	308	460	628	908	1.295	2.058									

GALAXY WITH NUT FOR WATER METERS

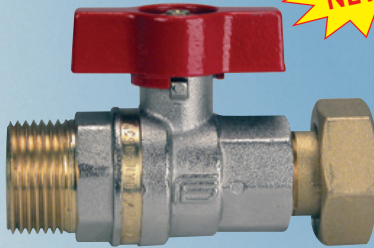

Art. 2162R424 male 1/2" ISO 228 / turnable nut 3/4"
Art. 2164R405 male 3/4" ISO 228 / turnable nut 3/4"

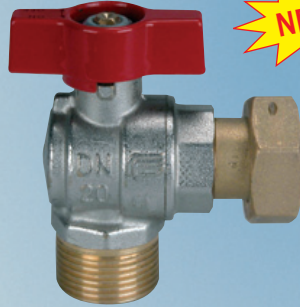

Art.2166R424 angle, male 1/2" ISO 228 / turnable nut 3/4"
Art. 2168R405 angle, male 3/4" ISO 228 / turnable nut 3/4"

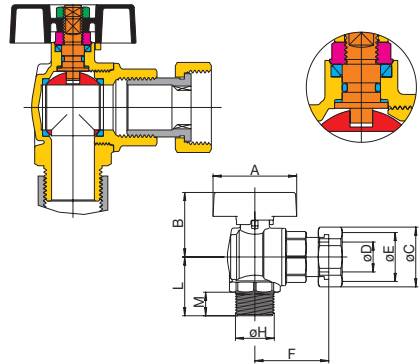
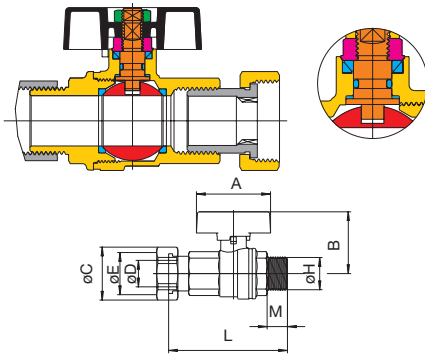
TECHNICAL FEATURES

Temperature limits: for fluids from -15°C to +120°C
Pressure limits: for fluids PN 63 for gas MOP 5

Operation devices:

Aluminium T-handle.
Available colours: red or yellow.

SPECIFIC FEATURES

Models: male/turnable nut for water meters with sealing hole on nut, 1,5 mm bore.

- blow-out proof stem
- Does not need any maintenance as it is equipped with wrapping seals ensuring long-life cycles.
- 1 antifriction ring forms the first automatic sealing at high pressure
- 2 PTFE cone-shaped sliding seals without wear form the second sealing at low pressure
- 1 NBR O-Ring for sealing at very low pressure and vacuum
- All valves are tested according to a strict procedure covering severe inspections on the entire production.
- For pressure and temperature table refer to Galaxy.

LIST OF COMPONENTS description/materials/treatments

Body and threaded end	yellow	half-stamped from bar	CW617N	UNI EN 12165
Gland	violet	machined from bar	CW614N	UNI EN 12164
Stem	orange	machined from bar	CW614N	UNI EN 12164
Chromium-plated polished ball	red	machined from bar	CW614N	UNI EN 12164
Nut	yellow	half-stamped from bar	CW617N	UNI EN 12165
Seats	blue	virgin PTFE	CW617N	UNI EN 12165
Stem o-ring	blue	NBR		
Operation device	black	die-cast aluminium alloy polyurethane c.		DIN 3535
Fixing screw	green	zinc-plated steel		UNI 5076
Surface treatment	--	brilliant nickel-plating		

GENERAL TABLE:

	STRAIGHT		ANGLE	
	15	20	15	20
nominal diameter	15	20	15	20
gas size in inch	1/2" x 3/4"	3/4" x 3/4"	1/2" x 3/4"	3/4" x 3/4"
Ø D bore mm	15	15	15	15
A mm	47	47	47	47
B mm	37,5	37,5	37,5	37,5
Ø C mm	34	34	34	34
Ø E mm	3/4"	3/4"	3/4"	3/4"
F mm			42,3	42,3
Ø H mm	1/2"	3/4"	1/2"	3/4"
L mm	75,8	79,3	31,5	35
M mm	11,7	15,2	12	16

TAPPY

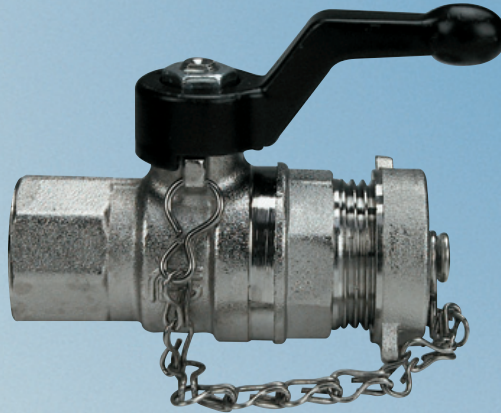

Art. 2151 1/2" plug with aluminium lever handle



Art. 2152 m/plug with aluminium lever handle



Art. 2156 1/2" plug with square cap



Art. 2157 m/plug with square cap



Art. 2161 1/2" hose union+plug and aluminium lever handle

TAPPY

TECHNICAL FEATURES:

Temperature limits: from -15°C to +120°C

Pressure limits: for fluids 40 bar

Application fields:

The TAPPY valve is designed particularly to be used as draining valve for boiler.

SPECIFIC FEATURES:

- the TAPPY valve, with reduced bore, is compact, versatile and easy to install.
- in the square cap version, the plug may be used as wrench for the handling of the cap.
- blow-out proof stem.
- does not need any maintenance, is equipped with wrapping seats ensuring long life cycles.
- the stem packing is composed of 3 seals: two O-rings for low pressures and an anti-friction ring in PTFE for high pressure.
- all EFFEBI valves are tested according to a strict procedure covering severe inspections on the entire production.

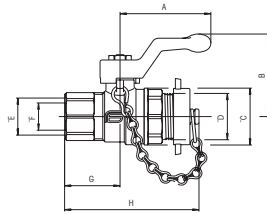
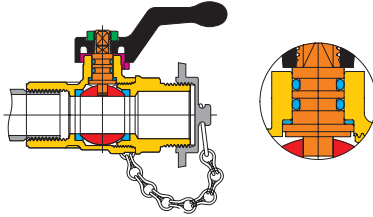

LIST OF COMPONENTS: description/materials/treatments

body and threaded end	yellow	machined from bar	CW617N	UNI EN 12165
stem	orange	machined from bar	CW614N	UNI EN 12164
chromium pl. polished ball	red	machined from bar	CW614N	UNI EN 12164
seals	blue	virgin PTFE		
stem o-ring	blue	O-ring	NBR	DIN 3535
operation device	black	die-cast aluminium alloy polyur. c.		UNI 5076
fixing screw	green	zinc-plate steel		
surface treatment	-	brilliant nickel plating		
dope		loctite AVX 586		
plug		hot stampod from bar	CW617N	UNI EN 12165
echain		nickel plated	CW614N	UNI EN 21164
plug packing		rubber		

GENERAL TABLE: valve dimensions per type and size

nominal diameter	15																		
gas size in inch	1/2"x3/4"																		
Ø bore mm	15																		
A mm	50																		
B mm	46																		
Ø C mm	31																		
E mm	3/4"																		
F mm	1/2"																		
L mm	31																		
weight gr	74																		

PRESSURE/TEMPERATURE DIAGRAM

at each pressure level corresponds a specific admissible temperature level and viceversa

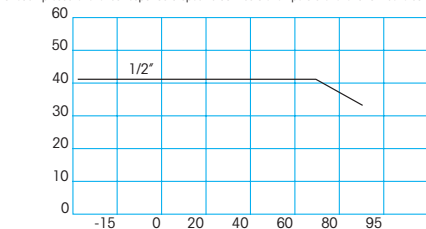

LOSS OF HEAD DIAGRAM:

the KV value is the port capacity causing a pressure drop of 1 bar.

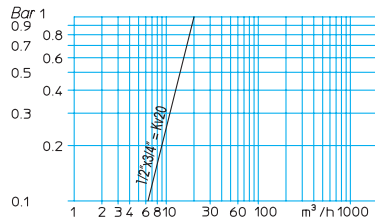

HIPRESS

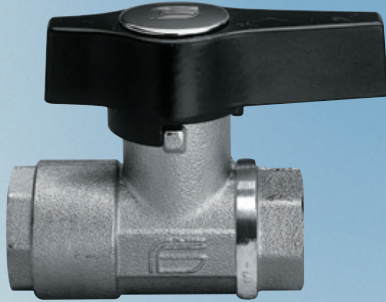
PN210

Art. 2321 for high pressure F/F with T-handle. Available range: from 3/8" to 1"

TECHNICAL FEATURES:

Temperature limits: for fluids from -20°C to +80°C
Pressure limits: for fluids 210 bar

Application fields:

HIPRESS series is particularly recommended for hydraulic installations, pneumatics and industrial plants in general, in presence of high pressures

Threaded end connections:

- Standard Female to ISO 7/1 Rp

Operation devices:

Aluminium T-handle Available colours: black.

SPECIFIC FEATURES:

- The HIPRESS valve, with reduced bore, has been designed for high pressures in a monobloc piece of high sturdiness.
- does not need any maintenance, is equipped with special seals ensuring long life cycles.
- all valves are tested according to a strict procedure covering severe inspections on the entire production.

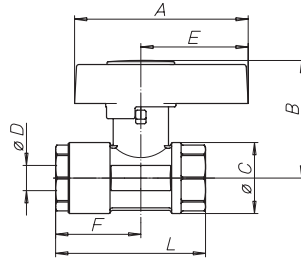
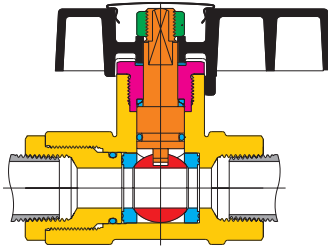
LIST OF COMPONENTS: description/materials/treatments

body and threaded end	yellow	hot stamped from bar	CW617N	UNI EN 12165
gland	violet	machined from bar	CW614N	UNI EN 12164
stem	orange	machined from bar	CW617N	UNI EN 12164
chromium pl. polished ball	red	machined from bar	CW617N	UNI EN 12164
seals	blue	acetalic resin		
stempacking	blue	O-ring		
operation device	black	die-cast alumin. alloy polyur. c.		UNI 5076
fixing nut	green	zinc plated steel		
T-handle cover	black	chromium plated brass		
surface treatment	-	brilliant nickel-plating		

GENERAL TABLE: valve dimension per type and size

nominal diameter	10	15	20	25
gas size in inch	3/8"	1/2"	3/4"	1"
Ø bore mm	8	12	16	20
A mm	73	73	110	110
B mm	54	56	75	77
Ø C mm	30	36	45	53
E mm	43	43	68	68
F mm	44	47	54	56
L mm	75	85	95	105
weight gr	482	637	1179	1536

LOSS OF HEAD DIAGRAM:

the kv value is the port capacity causing a pressure drop of 1 bar.

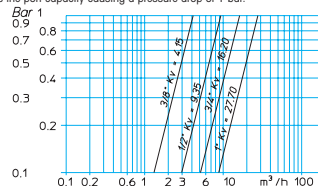

TOTAL EXTRA

Art. 2330 F/F with extractable kit with lever in aluminium. Available range: 1/2" to 3/4"

Art. 7300
 Kit ball/stem/gland/seals

TECHNICAL FEATURES:

 Temperature limits: for fluids from -20°C to +100°C
 Pressure limits: for fluids PN 16

Application fields: TOTAL EXTRA series is particularly recommended for installations where the medium has a strong wearing power against the inside valve components with the consequent requirement for frequent and quick replacement of the interception device.

Threaded end connections: • Standard female/female to ISO 7/1 Rp

Operation devices: Aluminium lever. Available colours: black.

SPECIFIC FEATURES:

- the TOTAL EXTRA series, with full bore, is conceived in order to allow at all time to replace all the inside components without dismantling the valve from the installation: the body is a solid stamping without any connection, therefore without any possible leakage and is integral with the pipe where it is installed.
- safety: the valve is designed to cope with installation pressure up to 100° C temperature.
- working life: the ball rotates perfectly supported on its axis so as to avoid any stress on the seats, thus guaranteeing long life cycles in full safety.
- the possible inside worn components are easily replaceable by the relevant kits.

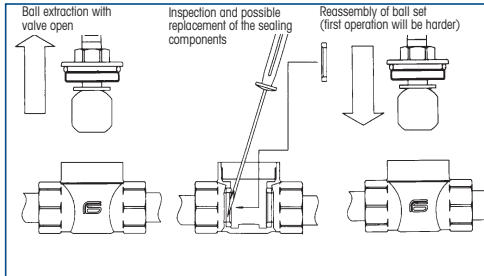
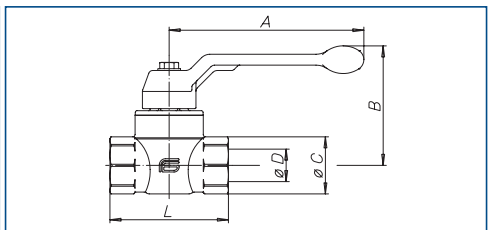
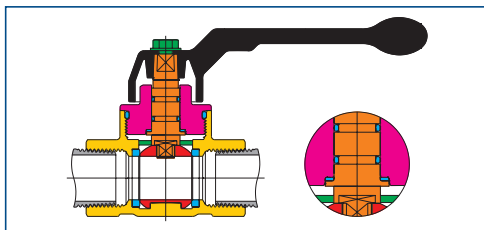
PRESSURE/TEMPERATE DIAGRAM:

at each pressure level corresponds a specific admissible temperature level and viceversa

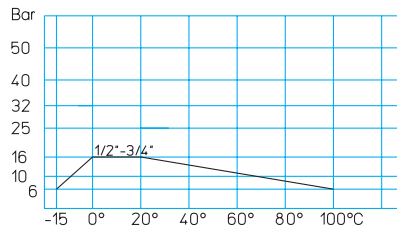

LIST OF COMPONENTS: description/materials/treatments

description	materials	treatments
body	yellow	hot stamped from bar CW617N UNI EN 12165
gland	violet	machined from bar CW614N UNI EN 12164
stem	orange	machined from bar CW617N UNI EN 12164
chromium pl. ball	red	machined from bar CW617N UNI EN 12164
seals	blue	virgin PTFE
stem packing o-rings	blue	NBR DIN 3535
operation device	black	die-cast alumin. polyur. c. UNI 5076
fixing nut	green	zinc plated steel
washer	green	stainless steel Aisi 304
surface treatment	-	brilliant nickel-plating

GENERAL TABLE: valve dimensions per type and size

nominal diameter	15	20
gas size in inch	1/2"	3/4"
Ø D bore mm	15	20
A mm	120	120
B mm	71	74
Ø C mm	29	35
L mm	64	73
weight gr	400	565

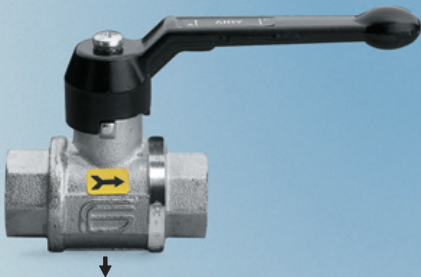
AIRY



Art. 2351 F/F with lever in aluminium, with exhaust. Available range: from 1/4" to 2"

TECHNICAL FEATURES:

Temperature limits: for fluids from -0°C to +60°C
Pressure limits: for fluids 40 bar

Application fields:

AIRY series is used specifically in compressed air installations

Threaded end connections:

- Standard Female to ISO 7/1 Rp

Operation devices:

Aluminium lever handle. Available colours: black.

SPECIFIC FEATURES:

- The AIRY valve, with full bore, is a product derived from TOTAL series. In order to exhaust the compressed air inside the downstream pipe section and avoid damages to the seats the ball is drilled transversally whereas the valve body is drilled at the bottom, as shown in the cross sectioned valve.
- does not need any maintenance, is equipped with wrapping seats ensuring high life cycles.
- Four self-adjusting cone-shaped seals, with PTFE-PTFE sliding, therefore without wear, form two sealings with automatic functioning.
- An adjusting gland allows the sealing reset on the stem.
- all valves are tested according to a strict procedure covering severe inspections on the entire production.

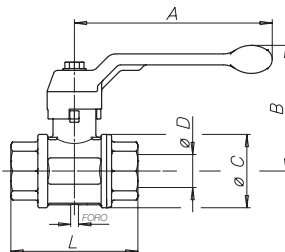
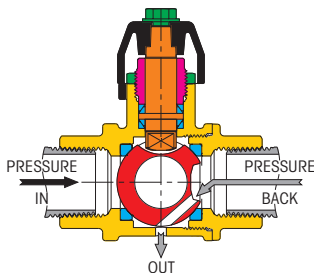
LIST OF COMPONENTS: description/materials/treatments

body and threaded end	yellow	hot stamped from bar	CW617N	UNI EN 12165
gland	violet	machined from bar	CW614N	UNI EN 12164
gland nut	green	machined from bar	CW614N	UNI EN 12164
stem	orange	machined from bar	CW617N	UNI EN 12164
chromium pl. polished ball	red	machined from bar	CW617N	UNI EN 12164
seals	blue	virgin PTFE		
operation device	black	die-cast alumin. alloy polyur c.		UNI 5076
fixing screw	green	zinc plated steel		
surface treatment	—	brilliant nickel-plating		

GENERAL TABLE: valve dimensions per type and size

nominal diameter	8	10	15	20	25	32	40	50				
gas size in inch	1/4"	3/8"	1/2"	3/4"	1"	1 1/4"	1 1/2"	2"				
Ø D bore mm	10	10	15	20	25	32	40	50				
A mm	100	100	100	120	120	150	150	175				
B mm	61	61	64	76	80	98	104	119				
Ø C mm	29	29	36	45	54	65	79	96				
L mm	52	55	69	77	89	103	114	134				
weight gr	245	245	370	635	890	1550	2300	3630				
vent	2,5	2,5	2,5	2,5	2,5	2,5	2,5	2,5				

DRAINY



Art. 2371 F/F with drain cock and plug with steel lever. Available range: from 1/2" to 1"

TECHNICAL FEATURES:

Temperature limits: for fluids from -15°C to +100°C
Pressure limits: for fluids 40 bar

Application fields:

DRAINY series is employed in water and heating installations.

Threaded end connections:

- Standard. Female and male to ISO 228/1

Operation devices:

Steel lever handle. Available colours: black.

SPECIFIC FEATURES:

- The DRAINY valve, with full bore, is provided with a side boiler discharge little valve and with a threaded drilling for the possible connection of a pressure gauge.
- blow-out proof stem.
- does not need any maintenance, is equipped with wrapping seats ensuring high life cycles
- all valves are tested according to a strict procedure covering severe inspections on the entire production

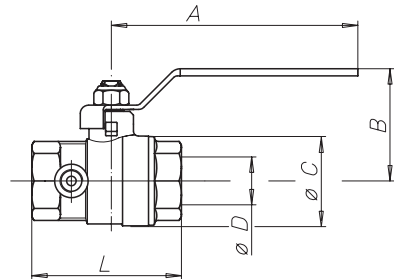
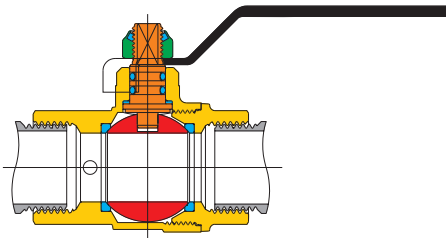
LIST OF COMPONENTS: description/materials/treatments

body and threaded end	yellow	hot stamped from bar	CW617N	UNI EN 12165
stem	orange	machined from bar	CW617N	UNI EN 12164
chromium pl. polished ball	red	machined from bar	CW617N	UNI EN 12164
seals	blue	virgin PTFE		
stem packing	blue	O-ring in NBR		DIN 3535
operation device	black	zinc plated steel, PVC coated		
fixing nut	green	zinc plated steel		
surface treatment	—	brilliant nickel-plating		

GENERAL TABLE: valve dimensions per type and size

DN	15	20	25						
gas size in inch	1/2"	3/4"	1"						
Ø D mm	15	20	25						
A mm	85	105	105						
B mm	41	48	52						
Ø C mm	30	38	4 6						
female L mm	58	65	75						
female weight gr	247	373	548						

ASTER WITH DRAIN



Art. 2374 F/F with drain and aluminium lever from 1/2" to 2"



Art. 2375 F/F with turnable drain and aluminium lever from 1/2" to 2"

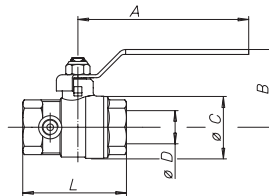
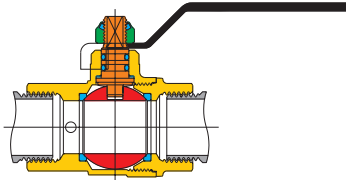

TECHNICAL FEATURES:

Temperature limits: for fluids from -15°C to +100°C
Pressure limits: for fluids PN40

Application fields:

The ASTER series with drain is mainly used for heating and water systems.

Threaded end connections:

• Standard female according to UNI ISO 228/1.

Operation devices:

Aluminium lever. Available colours: red.

SPECIFIC FEATURES

- Art. 2374 ASTER full bore ball valve is provided with a drain for liquids generally used for heating, air-conditioning and water systems and a threaded Tee branch for pressure or temperature source.
- Art. 2375 ASTER full bore ball valve is provided with a turnable drain for easy connection of a drainage pipe for liquids normally used in heating, air-conditioning and water systems.
The drain is closed by a knurled knob.
- Does not need any maintenance as it is equipped with wrapping seats ensuring long-life cycles.
- All valves are tested according to a strict procedure covering severe inspections on the entire production.
- For pressure and temperature table refer to Aster.

LIST OF COMPONENTS description/materials/treatments

Body and threaded end	yellow	hot-stamped from bar	CW617N	UNI EN 12165
Stem	orange	machined from bar	CW614N	UNI EN 12164
Chromium-plated polished ball	red	machined from bar	CW614N	UNI EN 12164
Seats	blue	virgin PTFE		
Stem o-ring	blue	NBR		UNI 5076
Operation device	black	die-cast aluminium alloy polyurethane c.		
Fixing screw	green	zinc-plated steel		
Surface treatment	--	brilliant nickel-plating		

GENERAL TABLE: valve dimensions per type and size

nominal diameter	15	20	25	32	40	50								
gas size in inch	1/2"	3/4"	1"	1 1/4"	1 1/2"	2"								
Ø D bore mm	15	20	25	32	40	50								
A mm	85	105	105	130	130	165								
B mm	41	48	52	63	69	83								
Ø C mm	30	38	46	57,5	70	85,5								
L mm	58	65	75	86,5	98	116								
weight gr	247	373	568	886	1297	2149								

SONDA

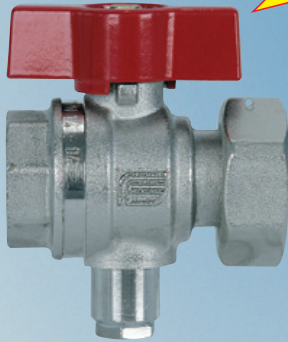

Art 4789

TECHNICAL FEATURES:

Temperature limits: For fluids: -15°C +100°C (with a maximum of 130°C)

Pressure limits: For fluids: PN 32

Application fields:

- The ball valve "Sonda" is used in central heating systems and where it is necessary to have a temperature/pressure point.
- Usually a valve at the beginning of the system and another one at the end of it are installed in order to calculate the difference in temperature connected with heat meter.

Specific features:

- The full bore valve "Sonda" is an extremely rugged product.
- The valve has got a connection, M10x1 threaded. Removing the tap it is possible to insert in the valve body a measuring instrument that, thanks to the drilling in the lower part of the ball, goes to direct contact with the fluid that has to be intercepted.
- The sealing tap is drilled in order to allow the sealing of the valve to the meter.
- Blow-out proof system.
- It does not need maintenance, it is equipped with wrapping lateral seals that guarantee a high duration in the number of cycles.
- The stem package system is made up of 3 seals: two NBR o-ring seals for low pressure and a PTFE ring for high pressure.
- All EFFEBI valves are 100% tested according to a strict procedure covering severe inspections on the entire production.

Sizes: 3/4" x1"

Threading ends and connections: Female/ISO 228 sealing cap.

Operation devices: Red aluminium T-handle

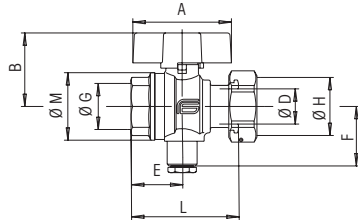
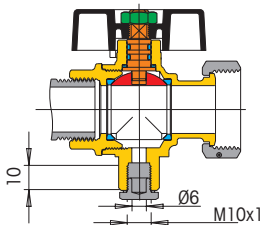

LIST OF COMPONENTS: description/materials/treatments

body and threaded end	yellow	hot stamped from bar	CW617N	UNI EN 12165
stem	orange	machined from bar	CW614N	UNI EN 12164
chromium pl. polished ball	red	machined from bar	CW617N	UNI EN 12164
seals	blue	virgin PTFE		
stem packing	blue	NBR		
operation device	black	die-cast alumin. alloy polyur. c.		UNI 5076
fixing nut	green	zinc plated steel		

GENERAL TABLE: valve dimensions per type and size

Nominal diameter	20																			
Gas size in inch	3/4"x1"																			
Ø D bore mm	20																			
A mm	56																			
B mm	42																			
E mm	29																			
Ø G	3/4"																			
F mm	33,8																			
Ø H	1"																			
Ø M	38,5																			
L mm	61																			
weight gr.	340																			

ISIS w

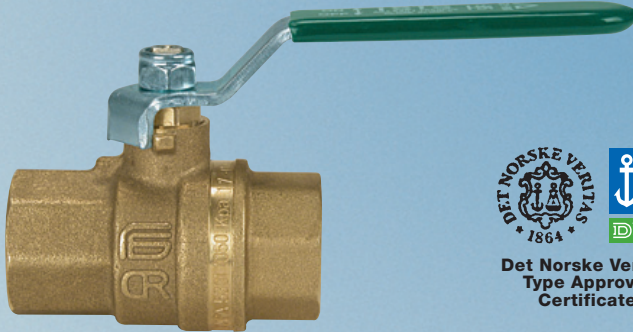

Det Norske Veritas
Type Approval
Certificate

Art. 2411 1/4" "CR" alloy with steel lever from 1/4" to 4"

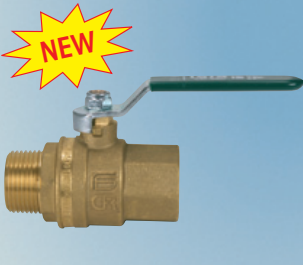

Art. 2412 MF from 1/2" to 1"



Art. 2415 copper-copper ends "CR" alloy with steel lever from 15mm to 54 mm



Art. 2421 1/4" "CR" alloy with T-handle from 1/4" to 1"



Art. 2481 1/4" "CR" alloy with extension from 1/4" to 2"

ISIS

TECHNICAL FEATURES:

Temperature limits: for fluids from -15°C to +120°C
Pressure limits: for fluids from 25 bar to 20 bar

Application fields:

ISIS series is manufactured with DZR copper alloy, studied on purpose for environmental protection. It is particularly suitable for those installations where high aggressive water causes zinc leaching in the standard brass alloys and weakens the material molecular structure.

Threaded end connections:

- Standard Female according to ISO 7/1 Rp
- On request Female according to ISO 7/1 Rc Male ISO 7/1

Operation devices:

Aluminium lever and T-handle, steel lever handle, Ralenty gear handle, extension.

Available colours:

green, black and yellow.

SPECIFIC FEATURES:

- The ISIS valve, with full bore, is a product particularly suitable for ensuring a high working reliability of medium pressure in water installations; it is certified by BRITISH GAS, by the WATER RESEARCH CENTRE, by DNV and by Watermark.
- blow-out proof stem.
- does not need any maintenance, is equipped with wrapping seats ensuring long life cycles.
- an anti-friction ring forms the first automatic sealing at high pressure.
- Two self-adjusting cone-shaped seats, with PTFE-PTFE sliding, therefore without wear, form the second sealing at low pressure.
- 1 O-Ring in EPDM for sealing at low pressure and vacuum
- all valves are tested according to a strict procedure covering severe inspections on the entire production.

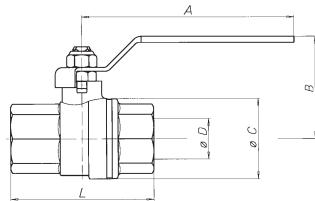
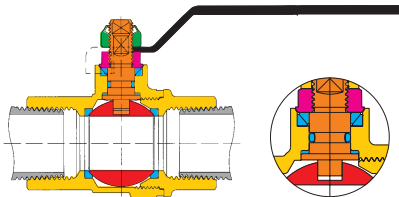

LIST OF COMPONENTS: description/materials/treatments

Component	Description	Material/Treatment	Code	UNI EN
body and threaded end	yellow	hot stamped from bar	CW602N	UNI EN 12165
gland	violet	machined from bar	CW614N	UNI EN 12164
stem	orange	machined from bar	CW602N	UNI EN 12164
chromium pl. polished ball	red	machined from bar	CW602N	UNI EN 12164
seals	blue	virgin PTFE		
O-ring	blue	EPDM		
operation device	black	zinc plated steel, PVC coated		
fixing nut	green	zinc plated steel		

GENERAL TABLE: valve dimensions per type and size

nominal diameter	8	10	15	20	25	32	40	50	65	80	100	
gas size in inch	1/4"	3/8"	1/2"	3/4"	1"	1 1/4"	1 1/2"	2"	2 1/2"	3"	4"	
Ø bore mm	10	10	15	20	25	32	40	50	65	80	100	
A mm	85	85	85	105	105	130	130	165	248	248	260	
B mm	37	37	44	52	56	63	69	83	108	123	142	
Ø C mm	27	27	32	40	48	60	72	88	135	167	167	
female	L mm	49	50	61	70	84	98	108	130	182,5	219	219
female	weight gr	190	175	226	386	588	962	1520	2650	3900	5990	10130

PRESSURE/TEMPERATURE DIAGRAM

at each pressure level corresponds a specific admissible temperature level and viceversa

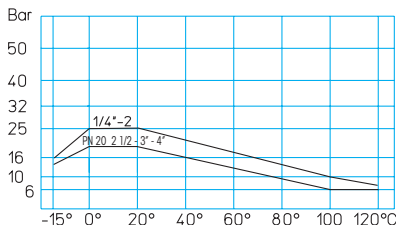

LOSS OF HEAD DIAGRAM:

the Kv value is the port capacity causing a pressure drop of 1 bar.

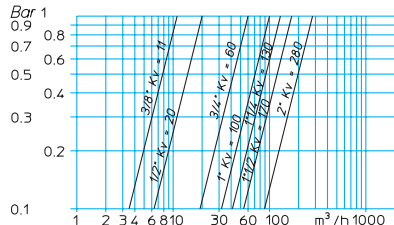

Y STRAINER VALVE



Art. 2435 F/F ISO 7/1 Rc "CR" alloy with handle from 1/2" to 1"

Temperature and pressure limits:

For fluids: from -15°C to +120°C
PN 25

Application fields:

The Y STRAINER combined valve, is manufactured with DZR copper alloy, projected on purpose for environmental protection. It is particularly suitable for those installations where high aggressive water causes zinc leakage in the standard brass alloys and weakens the material molecular structure. The incorporated strainer, makes the valve suitable for fluids with solid suspended particles.

Specific features:

- The Y STRAINER valve, with full bore, is an extremely robust product.
- Extremely compact because combines a ball valve with a Y strainer in a single product, therefore it allows to save space and time for installing.
- The incorporated strainer is in stainless steel with perforated metal sheet, instead of a metal net, for a bigger reliability and endurance.
- The valve has many points that, after to be finished, may be used to insert gauging instruments.
- Unscrewing the 1/4" threaded plug, is also possible to check the strainer and, if necessary, remove the deposited impurities. It's also possible, unscrewing the nut, to enow out the whole strainer.
- The materials and the seats are WRC patented.
- Blow-out proof stem.
- Does not need any maintenance, is equipped with wrapping seats ensuring long life cycles.
- An antifriction ring forms the first automatic sealing at high pressure.
- Two self-adjusting cone-shaped seats, with PTFE-PTFE sliding, therefore without wear, form the second sealing at low pressure.
- O-Ring in EPDM for sealing at very low pressure and vacuum.
- All EFFEBI valves are tested according to a strict procedure covering severe inspections on the entire production.

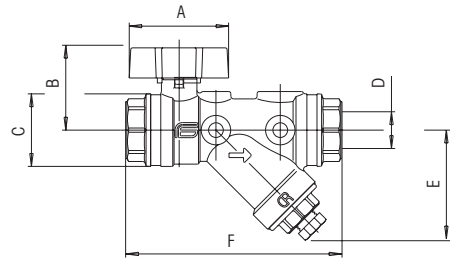
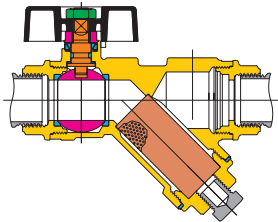

LIST OF COMPONENTS: description/materials/treatments

body and threaded end	yellow	hot stamped from bar	CW602N	UNI EN 12165
gland	violet	machined from bar	CW614N	UNI EN 12164
stem	orange	machined from bar	CW602N	UNI EN 12164
chromium pl. polished ball	red	machined from bar	CW602N	UNI EN 12164
seals	blue	virgin PTFE		
o-ring	blue	EPDM		
operation device	black	zinc plated steel, PVC coated		
fixing nut	green	zinc plated steel		
filter	brown	perforated metal sheet	AISI316	
filter plug	yellow	hot stamped from bar	CW602N	UNI EN 12165
drainage plug	gray	machined from bar	CW602N	UNI EN 12164

GENERAL TABLE: valve dimensions per type and size

nominal diameter	15	20	25										
gas size in inch	1/2"	3/4"	1"										
Ø D bore mm	15	20	25										
A mm	85	105	105										
B mm	43.8	52	55.8										
Ø C mm	34	42	49										
Ø E mm	44.5	56.3	59										
F mm	110	129	151.5										
weight gr	528	798	1180										

Y STRAINER VALVE



Art. 2435 Copper-Copper ends "CR" alloy with h-handle from 15 - 22 - 28 mm.

Temperature and pressure limits:

For fluids: from -15°C to +120°C
PN 25

Application fields:

The Y STRAINER combined valve, is manufactured with DZR copper alloy, projected on purpose for environmental protection.

Is particularly suitable for those installations where high aggressive water causes zinc leakage in the standard brass alloys and weakens the material molecular structure.

The incorporated strainer, makes the valve suitable for fluids with solid suspended particles.

Specific features:

- The Y STRAINER valve, with full bore, is an extremely robust product.
- Extremely compact because combines a ball valve with a Y strainer in a single product, therefore it allows to save space and time for installing.
- The incorporated strainer is in stainless steel with perforated metal sheet, instead of a metal net, for a bigger reliability and endurance.
- The valve has many points that, after to be finished, may be used to insert gauging instruments.
- Unscrewing the 1/4" threaded plug, is possible to check the strainer and, if necessary, remove the deposited impurities. It's also possible, unscrewing the nut, to draw out the whole strainer.
- The materials and the seals are WRC patented.
- Blow-out proof stem.
- Does not need any maintenance, is equipped with wrapping seats ensuring long life cycles.
- An antifriction ring forms the first automatic sealing at high pressure.
- Two self-adjusting cone-shaped seals, with PTFE-PTFE sliding, therefore without wear, form the second sealing at low pressure.
- O-Ring in EPDM for sealing at very low pressure and vacuum.
- All EFFEBI valves are tested according to a strict procedure covering severe inspections on the entire production.

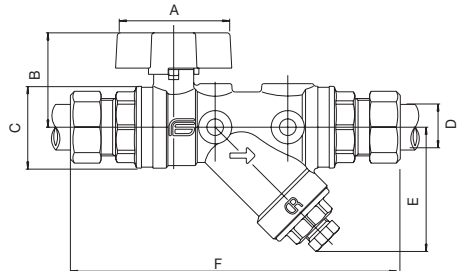
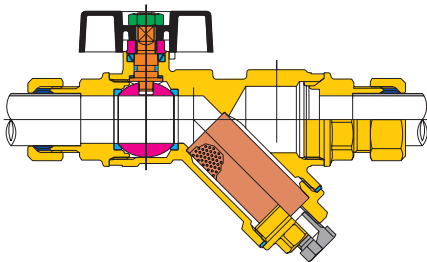
LIST OF COMPONENTS: description/materials/treatments

body and threaded end	yellow	hot stamped from bar	CW602N	UNI EN 12165
gland	violet	machined from bar	CW614N	UNI EN 12164
stem	orange	machined from bar	CW602N	UNI EN 12164
chromium pl. polished ball	red	machined from bar	CW602N	UNI EN 12164
seals	blue	virgin PTFE		
o-ring	blue	EPDM		
operation device	black	zinc plated steel, PVC coated		
fixing nut	green	zinc plated steel		
filter	brown	perforated metal sheet	AISI316	
filter plug	yellow	hot stamped from bar	CW602N	UNI EN 12165
drainage plug	yellow	machined from bar	CW602N	UNI EN 12164

GENERAL TABLE: valve dimensions per type and size

nominal diameter	15	20	25										
gas size in inch	1/2"	3/4"	1"										
Ø D bore mm	15	22	28										
A mm	47	56	56										
B mm	37,5	45,5	49,5										
Ø C mm	34	42	49										
Ø E mm	48	60	59										
F mm	137	159	174										
weight gr	570	892	1357										

KRONOS



Art. E 101 metal tube joint nut-female. Available range 3/8" to 2"



Art. E 102 metal tube joint nut-male 3/8" to 2"



Art. E 103 metal tube joint nut-nut 3/8" to 2"

KRONOS

TECHNICAL FEATURES: Temperature limits: for fluids from -20°C to +90°C
for gas from -20°C to + 60°C

Pressure limits: for fluids up to 50 bar
for gas PN 4

Application fields:

KRONOS metal tube joints are recommended for repairs in case of renovation of civil installations, in civil and industrial heating, in water distribution at medium pressure.

Threaded end connections:

• Standard female to ISO 7/1 Rp male to ISO 7/1 R

SPECIFIC FEATURES:

- Indispensable for a rapid intervention, easy and definitive on damaged pipes, the KRONOS metal tube joint is an ideal completion of the wide ball valve range produced by Effebi.
- In the three versions, nut-female, nut-male, nut-nut, KRONOS offers a complete possibility of intervention at low costs. The well-dimensioned body allows an easy assembly operation also in the most difficult cases. The sealing system by soft material seals (NBR) is designed in order to cover also a possible undersized tube diameter.
- The brass olive adheres also in presence of heavy surface tube deteriorations by means of a self-locking indent for a specific anti-sliding action and the surface chromium-plating guarantees big stoutness in the grip. The nuts are dimensioned to ensure a firmer grip.
- The KRONOS joint is tested for performances suitable for the widest applications, both for water (up to 50 bar) and for gas (4 bar).

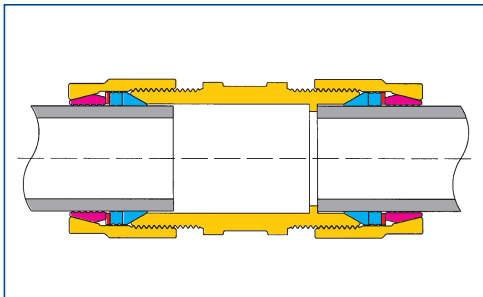

Installation instructions

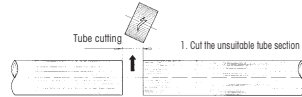

- For easy assembly use a lubricant
2. Blend slightly an end of the tube and insert the joint up to counterboring
 3. Re-align the tube and position the joint up to counterboring

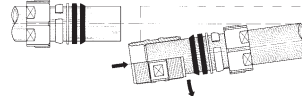

4. Screw adequately the nuts

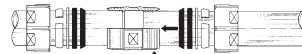

5. Tight nuts properly



LIST OF COMPONENTS: description/materials/treatments

body	yellow	hot stamped from bar	CW617N	UNI EN 12165
outside nuts	yellow	hot stamped from bar	CW617N	UNI EN 12165
ring	red	machined from bar	CW617N	UNI EN 12165
conical seal	blue	NBR	DIN 3535	
special seal	blue	NBR	DIN 3535	
olive	violet	machined from bar	CW617N	UNI EN 12165
surface treatment	-	brilliant nickel-plating		

Art. E 101 FEMALE JOINT

GENERAL TABLE: dimensions per type and size

nominal diameter	10	15	20	25	32	40	50
gas size in inch	3/8"	1/2"	3/4"	1"	1 1/4"	1 1/2"	2"
Ø bore mm	10	15	20	25	32	40	50
A mm	58	68	74	79	84	89	94
Ø B mm	29	33	40	47	58	64	77
weight gr	130	180	250	340	530	630	860

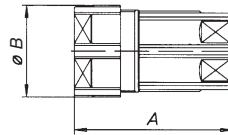

Art. E 102 MALE/NUT JOINT

GENERAL TABLE: dimensions per type and size

nominal diameter	10	15	20	25	32	40	50
gas size in inch	3/8"	1/2"	3/4"	1"	1 1/4"	1 1/2"	2"
Ø bore mm	10	15	20	25	32	40	50
A mm	58	68	74	79	84	89	94
Ø C mm	29	33	40	47	58	64	77
weight gr	125	170	235	325	510	615	870

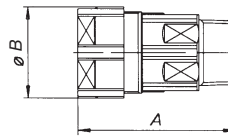

Art. E 103 NUT/NUT JOINT

GENERAL TABLE: dimensions per type and size

nominal diameter	10	15	20	25	32	40	50
gas size in inch	3/8"	1/2"	3/4"	1"	1 1/4"	1 1/2"	2"
Ø bore mm	10	15	20	25	32	40	50
A mm	86	86	90	90	102	103	104
Ø B mm	29	33	40	47	58	64	77
weight gr	220	270	365	460	720	815	1020

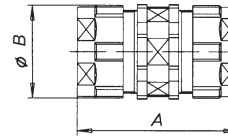

ATLANTIS

MAIN STANDARD FEATURES

- CONSTRUCTION :
 BODY IN CAST IRON: GG25 / ASTM A126-B
 DISC IN STAINLESS STEEL: ASTM A351 CF8 (AISI 304)
- General prescriptions: BS 5155 - MSS SP67 - API 609
 - DIAMETER: from DN40 to DN600
 - Connection with flanges:
 PN6-PN10-PN16-ANSI 150 from DN40 to DN300
 PN6-PN10 from DN350 to DN600
 - Maximum working pressure (between flanges):
 PN16 from DN40 to DN300
 PN10 from DN350 to DN600
 - TEMPERATURE LIMITS WITH SEALING SEATS IN:
 EPDM from -20°C to +110°C (with peaks up to +130°C)
 NBR from -20°C to +90°C (with peaks up to +100°C)
 VITON from -10°C to +160°C
 - Face to face dimensions in conformity with:
 BS5155 - ISO5752 - MSS SP67 - API609 - DIN3202/3-K1
 - Top flange with ISO5211 connection
 - Blow-out proof stem
 - Operation device: lever handle from DN40 to DN200
 manual reduction gear from DN250 to DN600
 - Tests: Hydraulic on body: 1.5 x nominal pressure
 Hydraulic for sealing: 1.1 x nominal pressure
 Pneumatic for sealing: 6 bar
 - Locking device from DN40 to DN200
 - Tested for vacuum of 1 -10⁻⁷ bar
 - Polyurethanic coating



STANDARD PART NUMBERS **Art. B101** WITH EPDM **Art. B102** WITH NBR



BOLTS AND TIE RODS DIMENSIONS

SIZE	PN10 Flanging			PN16 Flanging			SIZE	PN10 Flanging			PN16 Flanging		
	Ø x Length	holes	holes	Ø x Length	holes	holes		Ø x Length	holes	holes	Ø x Length	holes	holes
1 1/2"	40	M16x110	4	M16x110	4	4	1 1/2"	40	M16x90	4	M16x90	4	4
2"	50	M16x130	4	M16x130	4	4	2"	50	M16x100	4	M16x100	4	4
2 1/2"	65	M16x130	4	M16x130	4	4	2 1/2"	65	M16x100	4	M16x100	4	4
3"	80	M16x140	4	M16x140	4	4	3"	80	M16x100	8	M16x100	8	8
4"	100	M16x150	8	M16x150	8	8	4"	100	M16x110	8	M16x110	8	8
5"	125	M16x150	8	M16x150	8	8	5"	125	M16x120	8	M16x120	8	8
6"	150	M20x160	8	M20x160	8	8	6"	150	M20x120	8	M20x120	8	8
8"	200	M20x170	8	M20x170	12	8	8"	200	M20x130	8	M20x130	12	8
10"	250	M20x180	12	M24x190	12	12	10"	250	M20x140	12	M24x150	12	12
12"	300	M20x190	12	M24x200	12	12	12"	300	M20x160	12	M24x160	12	12
14"	350	M24x190	16	M24x220	16	14	14"	350	M20x160	16	M24x170	16	16
16"	400	M24x230	16	M27x240	16	16	16"	400	M24x190	16	M27x200	16	16
20"	500	M24x250	20	M30x280	20	20	20"	500	M24x200	20	M30x230	20	20
24"	600	M24x300	20	M33x300	20	24	24"	600	M24x260	20	M33x270	20	20

SPECIAL EXECUTIONS

- Yellow lever handle for gas
- Reduction gear with manual operation also for small DN
- Disc in AISI 316 or GGG40 nickel plated till DN200
- VITON seals
- For further special requests please consult our technical/commercial service

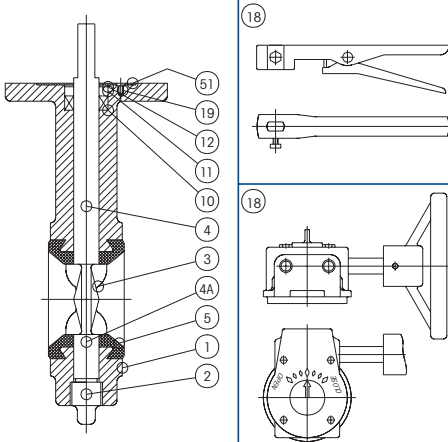

	APPLICATION FOR:	NOT RECOMMENDED FOR:
with EPDM	Water, sea water, steam, brine, esters, alcohols, ketones, caustic sodas, abrasive substances, food compounds, phosphates, inorganic acids, etc.	Hydrocarbons, oils, greases, dry air.
with NBR	Natural gas, air, water, sea water, pickle, oils and greases	Solvents, benzene, xylol.
VITON	Mineral oil, benzene, oil for hydraulic purposes and high temperatures, sulphuric acid propane.	Not recommended for glycolic fluids, vegetable oil, acetone ethylic acetate, acetic acid.

LIST OF VALVE COMPONENTS AND MATERIALS

REF.	PART	Q.ty	MATERIAL
1	BODY	1	CAST IRON GG25/ASTM A126-B
2	PLUG	1	NICKEL PLATED C. STEEL
3	DISC	1	CF8 (AISI 304)
4	STEM	1	TYPE 410
4A	LOWER STEM	1	TYPE 410
5	SEAT	1	EPDM or NBR
10	UPPER SEAL	1	EPDM or NBR
11	BUSHING	1	DELIRIN
12	RING	1	STEEL FOR SPRINGS
19	SCREW	2	NICKEL PLATED C. STEEL
51	WASHER	1	NICKEL PLATED C. STEEL
18	LEVER HANDLE	1	CARBON STEEL
18	REDUCTION GEAR	1	CAST IRON

ATLANTIS

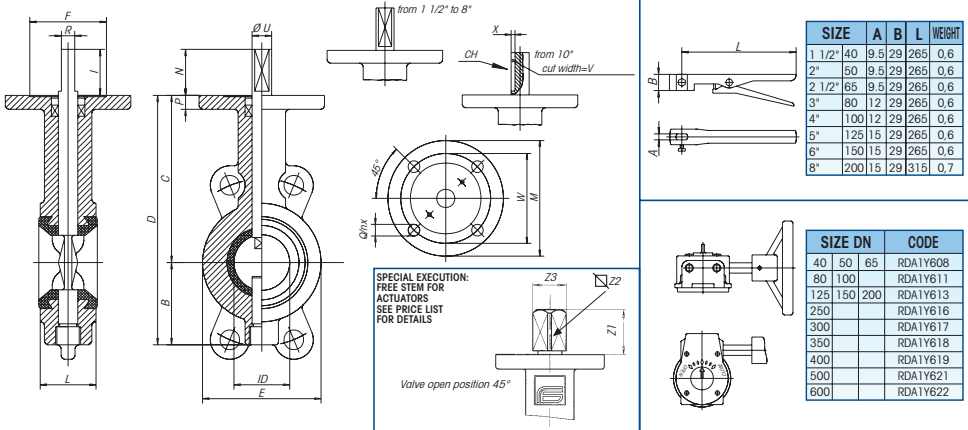

SIZE	A	B	L	WEIGHT	
1 1/2"	40	9.5	29	265	0.6
2"	50	9.5	29	265	0.6
2 1/2"	65	9.5	29	265	0.6
3"	80	12	29	265	0.6
4"	100	12	29	265	0.6
5"	125	15	29	265	0.6
6"	150	15	29	265	0.6
8"	200	15	29	315	0.7

SIZE DN	CODE		
40	50	65	RDAT1608
80	100		RDAT1611
125	150	200	RDAT1613
250			RDAT1616
300			RDAT1617
350			RDAT1618
400			RDAT1619
500			RDAT1621
600			RDAT1622

SIZE	STEM																	ISO 5211 CONNEX.						* WEIGHT	
	ID	L	B	C	D	E	P	N	I	R	U	X	V	Z1	Z2	Z3	CH	ISO CONN.	M	W	n	Q	F		
1 1/2"	40	40	40	59	120	179	85	10	33	30	9.5	14			16.5	11	14	F07	90	70	4	9	55	2.7	
2"	50	50	43	64	130	194	92	11	33	30	9.5	14			16.5	11	14	F07	90	70	4	9	55	2.9	
2 1/2"	65	63	46	72	137	209	107	11	33	30	9.5	14			16.5	11	14	F07	90	70	4	9	55	4.1	
3"	80	77	46	85	156	241	122	11	33	30	11.8	16			17.5	11	14	F07	90	70	4	9	55	4.4	
4"	100	100	52	95	170	265	150	11	33	30	11.8	16			17.5	11	14	F07	90	70	4	9	55	4.7	
5"	125	125	56	110	185	295	179	12	33	30	14.5	19			17.5	14	18	F07	90	70	4	9	55	6.3	
6"	150	147	56	123	203	326	206	12	33	30	14.5	19			22.5	14	18	F07	90	70	4	9	55	7.9	
8"	200	198	60	168	238	406	257	13	33	30	14.5	19			22.5	17	22	F07	90	70	4	9	55	12.3	
10"	250	244	68	203	270	473	316	15	65	60		22	4	8	27	22	28	8x7	F10	125	102	4	12	72	19.5
12"	300	298	78	242	310	552	370	15	65	60		28	4	8	27	22	28	8x7	F10	125	102	4	12	72	30.5
14"	350	337	78	290	330	620	410	15	65	60		28	4	8				8x7	F10	125	102	4	12	72	41
16"	400	387	102	330	375	705	468	20	75	70		38	5	12				12x8	F14	175	140	4	18	80	62
20"	500	487	127	400	440	840	578	20	100	95		45	5.5	14				14x9	F16	210	165	4	22	90	111
24"	600	575	154	460	510	970	680	22	100	95		55	5.5	14				14x9	F16	210	165	4	22	105	210

* WEIGHT REFERS TO VALVE WITH BARE SHAFT

BREAKAWAY TORQUES IN Nm																
DN size	40	50	65	80	100	125	150	200	250	300	350	400	500	600		
PN - bar	1 1/2"	2"	2 1/2"	3"	4"	5"	6"	8"	10"	12"	14"	16"	20"	24"		
0	11	14	18	27	40	59	88	157	248	343	485	662	1142	2385		
6	11	20	25	32	41	62	92	173	275	382	549	766	1327	2787		
10	12	23	27	34	54	71	106	186	321	576	680	882	1634	3250		
16	14	25	29	37	56	86	123	262	392	551	1528	2035	3070	5670		

The values in Nm may vary as a function of the seals material, temperature and type of medium. For a firm operation of the various types of actuators, in the different working conditions it is necessary to consider a safety factor of 1.5. During operation, with frequent open and close cycles, the operating torque can decrease considerably in comparison with the initial breakaway torque.

SIZE	Kv AND Cv VALUES AS A FUNCTION OF OPENING ANGLE																	
	20°		30°		40°		50°		60°		70°		80°		90°			
	Kv	Cv	Kv	Cv	Kv	Cv	Kv	Cv	Kv	Cv	Kv	Cv	Kv	Cv	Kv	Cv		
1 1/2"	40	2.6	3	4.3	5	9.5	11	16	18	22	26	39	45	60	70	69	80	
2"	50	6.7	8	7.8	9	16	18	24	28	48	55	62	72	95	110	116	135	
2 1/2"	65	8.6	10	13	15	23	27	38	44	73	85	95	110	145	168	181	210	
3"	80	13	15	20	23	34	39	56	65	112	130	142	165	216	250	267	310	
4"	100	23	27	35	41	61	71	99	115	198	230	259	300	401	465	466	540	
5"	125	50	58	74	86	129	150	211	245	414	480	526	610	845	980	948	1100	
6"	150	83	96	121	140	211	245	345	400	677	785	871	1010	1392	1615	1647	1910	
8"	200	142	165	211	245	354	410	591	685	1099	1275	1478	1715	2302	2670	2746	3185	
10"	250	220	255	328	380	560	650	974	1130	1810	2100	2328	2700	3664	4250	4224	4900	
12"	300	319	370	466	540	819	950	1353	1570	2629	3050	3405	3950	5129	5950	6336	7350	
14"	350	388	456	647	750	1120	1300	1905	2210	3517	4080	4836	5610	6964	8078	9655	11200	
16"	400	552	640	776	900	1483	1720	2405	2790	4310	5000	6336	7650	9284	10770	11121	12900	
20"	500	785	910	1375	1595	2457	2850	3991	4630	7414	8600	9914	11500	15121	17540	19310	22400	
24"	600	1078	1250	1974	2290	3448	4000	5250	6090	10776	12500	14224	16500	20336	23590	24397	28300	

ATLANTIS 40

MAIN STANDARD FEATURES

- CONSTRUCTION :
BODY IN CAST IRON: GGG40 / ASTM A536
DISC IN STAINLESS STEEL: ASTM A351 CF8 (AISI 304)
- General prescriptions: BS 5155 - MSS SP67 - API 609
 - DVGW GAS CERTIFICATION
 - DIAMETER: from DN40 to DN600
 - Connection with flanges:
 - PN6 - PN10 - PN16 from DN40 to DN300
 - PN6 - PN10 from DN350 to DN600
 - ANSI 150 from DN40 to DN300
 - Maximum working pressure (between flanges):
 - PN16 from DN40 to DN300
 - PN10 from DN350 to DN600
 - TEMPERATURE LIMITS WITH SEALING SEATS IN:
 - NBR from -20°C to + 90°C (with peaks up to +100°C)
 - VITON from -10 °C to + 160 °C
 - EPDM seals
 - Face to face dimensions in conformity with: BS5155 - ISO5752 - MSS SP67 - API609 - DIN3202/3-K1
 - Top flange with ISO5211 connection
 - Blow-out proof stem
 - Operation device: lever handle from DN40 to DN200 manual reduction gear from DN250 to DN600
 - Tests: Hydraulic on body: 1.5 x nominal pressure
Hydraulic for sealing: 1.1 x nominal pressure
Pneumatic for sealing: 6 bar
 - Locking device from DN40 to DN200
 - Tested for vacuum at 1 -10⁻⁷ bar
 - Polyurethanic coating

SPECIAL EXECUTIONS

- Black lever handle
- Reduction gear with manual operation also for small DN
- Disc in AISI 316
- VITON seals
- For further special requests please consult our technical/commercial service



DVGW GAS
CERTIFICATION VALVE
NR NG-4313AU2364

STANDARD PART NUMBERS
Art. B302 with NBR

BOLTS AND TIE RODS DIMENSIONS

SIZE		PN10 Flanging		PN16 Flanging		SIZE		PN10 Flanging		PN16 Flanging	
		Ø x Length	holes	Ø x Length	holes			Ø x Length	holes	Ø x Length	holes
1 1/2"	40	M16x110	4	M16x110	4	1 1/2"	40	M16x90	4	M16x90	4
2"	50	M16x130	4	M16x130	4	2"	50	M16x100	4	M16x100	4
2 1/2"	65	M16x130	4	M16x130	4	2 1/2"	65	M16x100	4	M16x100	4
3"	80	M16x140	8	M16x140	8	3"	80	M16x100	8	M16x100	8
4"	100	M16x150	8	M16x150	8	4"	100	M16x110	8	M16x110	8
5"	125	M16x150	8	M16x150	8	5"	125	M16x120	8	M16x120	8
6"	150	M20x160	8	M20x160	8	6"	150	M20x120	8	M20x120	8
8"	200	M20x170	8	M20x170	12	8"	200	M20x130	8	M20x130	12
10"	250	M20x180	12	M24x190	12	10"	250	M20x140	12	M24x150	12
12"	300	M20x190	12	M24x200	12	12"	300	M20x160	12	M24x160	12
14"	350	M20x190	16	M24x220	16	14"	350	M20x160	16	M24x170	16
16"	400	M24x230	16	M27x240	16	16"	400	M24x190	16	M27x200	16
20"	500	M24x250	20	M30x280	20	20"	500	M24x200	20	M30x230	20
24"	600	M24x300	20	M33x300	20	24"	600	M24x260	20	M33x270	20

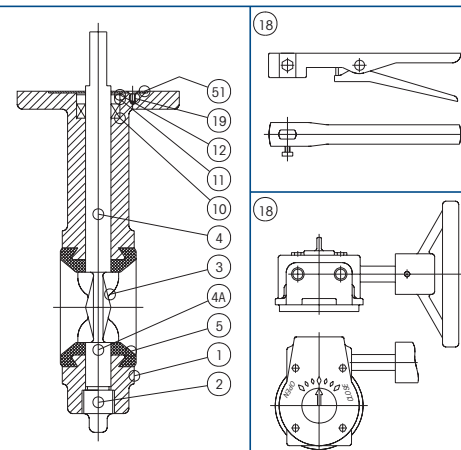

APPLICATION FOR:		NOT RECOMMENDED FOR:
with NBR	Natural gas, air, oils and greases.	Solvents, benzene, xylol.

LIST OF VALVE COMPONENTS AND MATERIALS

REF.	PART	Q.ty	MATERIAL
1	BODY	1	DUCTILE IRON GGG40/ASTM A536
2	PLUG	1	NICKEL PLATED C. STEEL
3	DISC	1	CF8 (AISI 304)
4	STEM	1	TYPE 410
4A	LOWER STEM	1	TYPE 410
5	SEAT	1	EPDM or NBR
10	UPPER SEAL	1	EPDM or NBR
11	BUSHING	1	DELIRIN
12	RING	1	STEEL FOR SPRINGS
19	SCREW	2	NICKEL PLATED C. STEEL
51	WASHER	1	NICKEL PLATED C. STEEL
18	LEVER HANDLE	1	CARBON STEEL
18	REDUCTION GEAR	1	CAST IRON

ATLANTIS 40

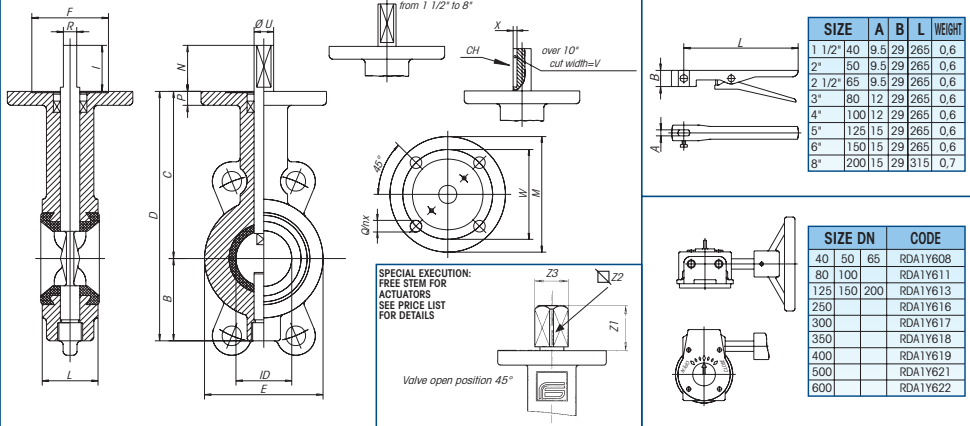

SIZE	STEM															ISO 5211 CONNec.						*			
	ID	L	B	C	D	E	P	N	I	R	U	X	V	Z1	Z2	Z3	CH	ISO CONN.	M	W	n		Q	F	WEIGHT
1 1/2"	40	40	40	59	120	179	85	10	33	30	9.5	14			16.5	11	14	F07	90	70	4	9	55	2.7	
2"	50	50	43	64	130	194	92	11	33	30	9.5	14			16.5	11	14	F07	90	70	4	9	55	2.9	
2 1/2"	65	63	46	72	137	209	107	11	33	30	9.5	14			16.5	11	14	F07	90	70	4	9	55	4.1	
3"	80	77	46	85	156	241	122	11	33	30	11.8	16			17.5	11	14	F07	90	70	4	9	55	4.4	
4"	100	100	52	95	170	265	150	11	33	30	11.8	16			17.5	11	14	F07	90	70	4	9	55	4.7	
5"	125	125	56	110	185	295	179	12	33	30	14.5	19			17.5	14	18	F07	90	70	4	9	55	6.3	
6"	150	147	56	123	203	326	206	12	33	30	14.5	19			22.5	14	18	F07	90	70	4	9	55	7.9	
8"	200	198	60	168	238	406	257	13	33	30	14.5	19			22.5	17	22	F07	90	70	4	9	55	12.3	
10"	250	244	68	203	270	473	316	15	65	60		22	4	8	27	22	28	8x7	F10	125	102	4	12	72	19.5
12"	300	298	78	242	310	552	370	15	65	60		28	4	8	27	22	28	8x7	F10	125	102	4	12	72	30.5
14"	350	337	78	290	330	620	410	15	65	60		28	4	8				8x7	F10	125	102	4	12	72	41
16"	400	387	102	330	375	705	468	20	75	70		38	5	12				12x8	F14	175	140	4	18	80	62
20"	500	487	127	400	440	840	578	20	100	95		45	5.5	14				14x9	F16	210	165	4	22	90	111
24"	600	575	154	460	510	970	680	22	100	95		55	5.5	14				14x9	F16	210	165	4	22	105	210

* WEIGHT REFERS TO VALVE WITH BARE SHAFT

BREAKAWAY TORQUES in Nm

PN - bar	DN size	40	50	65	80	100	125	150	200	250	300	350	400	500	600
		1 1/2"	2"	2 1/2"	3"	4"	5"	6"	8"	10"	12"	14"	16"	20"	24"
0	11	14	18	27	40	59	88	157	248	343	485	662	1142	2385	
6	11	20	25	32	41	62	92	173	275	382	549	766	1327	2787	
10	12	23	27	34	54	71	106	186	321	576	680	882	1634	3250	
16	14	25	29	37	56	86	123	262	392	551	1528	2035	3070	5670	

The values in Nm may vary as a function of the seals material, temperature and type of medium. For a firm operation of the various types of actuators, in the different working conditions it is necessary to consider a safety factor of 1.5. During operation, with frequent open and close cycles, the operating torque can decrease considerably in comparison with the initial breakaway torque.

Kv AND Cv VALUES AS A FUNCTION OF OPENING ANGLE

SIZE	Kv AND Cv VALUES AS A FUNCTION OF OPENING ANGLE																			
	20°		30°		40°		50°		60°		70°		80°		90°					
	Kv	Cv	Kv	Cv	Kv	Cv	Kv	Cv	Kv	Cv	Kv	Cv	Kv	Cv	Kv	Cv				
1 1/2"	40	2.6	3	4.3	5	9.5	11	16	18	22	26	39	45	60	70	69	80			
2"	50	6.7	8	7.8	9	16	18	24	28	48	55	62	72	95	110	116	135			
2 1/2"	65	8.6	10	13	15	23	27	38	44	73	85	95	110	145	168	181	210			
3"	80	13	15	20	23	34	39	56	65	112	130	142	165	216	250	267	310			
4"	100	23	27	35	41	61	71	99	115	198	230	259	300	401	465	466	540			
5"	125	50	58	74	86	129	150	211	245	414	480	526	610	845	980	948	1100			
6"	150	83	96	121	140	211	245	345	400	677	785	871	1010	1392	1615	1647	1910			
8"	200	142	165	211	245	354	410	591	685	1099	1275	1478	1715	2302	2670	2746	3185			
10"	250	220	255	328	380	560	650	974	1130	1810	2100	2328	2700	3664	4250	4224	4900			
12"	300	319	370	466	540	819	950	1353	1570	2629	3050	3405	3950	5129	5950	6336	7350			
14"	350	388	450	647	750	1120	1300	1905	2210	3517	4080	4836	5610	6964	8078	8655	11200			
16"	400	552	640	776	900	1483	1720	2405	2790	4310	5000	6336	7650	9284	10770	11121	12900			
20"	500	785	910	1375	1595	2457	2850	3991	4630	7414	8600	9914	11500	15121	17540	19310	22400			
24"	600	1078	1250	1974	2290	3448	4000	5250	6090	10776	12500	14224	16500	20336	23590	24397	28300			

ATLANTIS

ACTUATOR FEATURES

- Rotation angle: 90°
- Standard version for temperature between -20°C and + 90°C
- Supply maximum pressure: 10 bar
- Nominal pressure: 5,62 bar
- Supply medium: dry filtered compressed air, not necessarily lubricated
- Lubrication: in such a case use a non-detergent or NBR compatible oil

STANDARD VALVE FEATURES

- General prescriptions: BS 5155, MSS SP67, API 609
- Temperature limits with sealing seats in:
EPDM from -20 °C to +110 °C (with peaks up to +130 °C)
NBR from -20 °C to + 90 °C (with peaks up to +100 °C)
VITON from -10 °C to + 160 °C
- Maximum working pressure with actuator:
PN 16 from DN 40 to DN 200, PN 10 from DN 250 to DN 300
- For general applications and special versions see technical table of manual valve
- In the below table the part number and the valve code refer to the standard valve in GG25, with seats in EPDM.



SIZE	PART NUMBER	weight in gr.	A	B	C	D	E	F	G	L	P	M	ACTUATOR code	VALVE code	MOUNTING KIT code
1 1/2"	DB1AA60800	4000	133	70	88	40	85	248	59	40	10	90	DGA063AX00	VB11Y608	KANX0008
2"	DB1AA60900	4200	133	70	88	40	92	258	64	43	11	90	DGA063AX00	VB11Y609	KANX0008
2 1/2"	DB1AA61000	5350	133	70	88	40	107	265	72	46	11	90	DGA063AX00	VB11Y610	KANX0008
3"	DB1AA61100	6250	132	83	100	40	122	296	85	46	11	90	DGA075AX00	VB11Y611	KANX0008
4"	DB1AA61200	7100	182	91	108	40	150	318	95	52	11	90	DGA083AX00	VB11Y612	KANX0008
5"	DB1AA61300	9500	203	100	117	40	179	342	110	56	12	90	DGA092AX00	VB11Y613	KANX0008
6"	DB1AA61400	12550	222	120	140	40	206	383	123	56	12	90	DNA110AX00	VB11Y614	KANX0008
8"	DB1AA61500	20650	300	137	127	40	257	405	168	60	13	90	DNA127AX00	VB11Y615	KANX0008
10"	DB1AA61600	26100	380	172	198	50	316	518	203	68	15	125	DNA160AX00	VB11Y616	KANX0016
12"	DB1AA61700	36100	380	172	198	50	370	558	242	78	15	125	DNA160AX00	VB11Y617	KANX0016

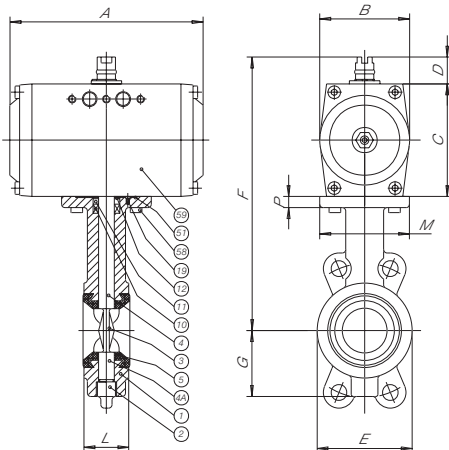

LIST OF VALVE COMPONENTS AND MATERIALS

REF. PART	Q.ty	MATERIAL
1 BODY	1	CAST IRON GG25/ASTM A126-B
2 PLUG	1	NICKEL PLATED C.S.
3 DISC	1	CF8 (AISI 304)
4 STEM	1	TYPE 410
4A LOWER STEM	1	TYPE 410
5 SEAT	1	EPDM or NBR
10 UPPER SEAL	1	EPDM or NBR
11 BUSHING	1	DELTRIN
12 RING	1	STEEL FOR SPRINGS
19 SCREW	2	NICKEL PLATED C.S.
51 WASHER	1	NICKEL PLATED C.S.
58 ACTUATOR SCREW	4	8.8
59 ACTUATOR	1	

Actuator connections: 1/8" G. type from DGA052 to DGA092
1/4" G. Namur type from DNA110 to DNA255 and DNA045
For accessories see relevant catalogue sheet

ATLANTIS

ACTUATOR FEATURES

- Rotation angle: 90°
- Standard version for temperature between -20°C and + 90°C
- Supply maximum pressure: 10 bar
- Nominal pressure: 5,62 bar
- Supply medium: dry filtered compressed air, not necessarily lubricated
- Lubrication: in such a case use a non-detergent or NBR compatible oil
- STANDARD: SPRING CLOSURES/AIR OPENS, clockwise automatic closing

STANDARD VALVE FEATURES

- General prescriptions: BS 5155, MSS SP67, API 609
- Temperature limits with sealing seats in: EPDM from -20 °C to +110 °C (with peaks up to +130 °C)
NBR from -20 °C to + 90 °C (with peaks up to +100 °C)
VITON from -10 °C to + 160 °C
- Maximum working pressure with actuator:
PN 16 from DN 40 to DN 200, PN 10 from DN 250 to DN 300
- For general applications and special versions see technical table of manual valve
- In the below table the part number and the valve code refer to the standard valve in GG25, with seats in EPDM.



SIZE	PART NUMBER	weight in gr.	A	B	C	D	E	F	G	L	P	M	ACTUATOR code	VALVE code	MOUNTING KIT code
1 1/2"	SB1AA60800	4835	132	83	100	40	85	260	59	40	10	90	SGA0754X00	VB11Y608	KANX0008
2"	SB1AA60900	5620	182	91	108	40	92	278	64	43	11	90	SGA0834X00	VB11Y609	KANX0008
2 1/2"	SB1AA61000	7650	203	100	117	40	107	294	72	46	11	90	SGA0924X00	VB11Y610	KANX0008
3"	SB1AA61100	9765	222	120	140	40	122	336	85	46	11	90	SNA1104X00	VB11Y611	KANX0008
4"	SB1AA61200	10070	222	120	140	40	150	350	95	52	11	90	SNA1104X00	VB11Y612	KANX0008
5"	SB1AA61300	15780	300	137	160	40	179	385	110	56	12	90	SNA1274X00	VB11Y613	KANX0008
6"	SB1AA61400	26385	380	172	198	50	206	451	123	56	12	90	SNA1604X00	VS11Y614	KAPX0014
8"	SB1AA61500	49250	450	224	255	50	257	543	168	60	13	90	SNA2104X00	VS11Y615	KAPX0015
10"	SB1AA61600	49700	450	224	255	50	316	575	203	68	15	125	SNA2104X00	VS11Y616	KAPX0016
12"	SB1AA61700	95770	603	272	302	50	370	662	242	78	15	125	SNA2544X00	VS11Y617	KAPX0017

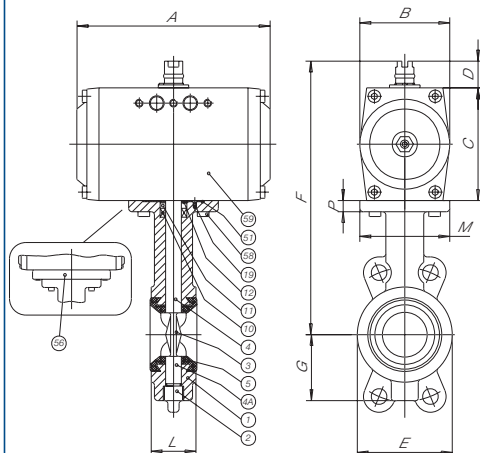

LIST OF VALVE COMPONENTS AND MATERIALS

REF.	PART	Q.ty	MATERIAL
1	BODY	1	CAST IRON GG25/ASTM A126-B
2	PLUG	1	NICKEL PLATED C.S.
3	DISC	1	CF8 (AISI 304)
4	STEM	1	TYPE 410
4A	LOWER STEM	1	TYPE 410
5	SEAT	1	EPDM or NBR
10	UPPER SEAL	1	EPDM or NBR
11	BUSHING	1	DELTRIN
12	RING	1	STEEL FOR SPRINGS
19	SCREW	2	NICKEL PLATED C.S.
51	WASHER	1	NICKEL PLATED C.S.
56	BRACKET	1	C.S.
57	BRACKET/VALVE SCREW	4	8.8
58	ACTUATOR SCREW	4	8.8
59	ACTUATOR	1	

Bracket with screws only from DN150 to DN300

Actuator connections: 1/8" G. type from SGA052 to SGA092
1/4" G. Namur type from SNA110 to SNA255
and SNA045

For accessories see relevant catalogue sheet

ATLANTIS 40

ACTUATOR FEATURES

- Rotation angle: 90°
- Standard version for temperature between -20°C and + 90°C
- Supply maximum pressure: 10 bar
- Nominal pressure: 5,62 bar
- Supply medium: dry filtered compressed air, not necessarily lubricated
- Lubrication: in such a case use a non-detergent or NBR compatible oil

STANDARD VALVE FEATURES

- General prescriptions: BS 5155, MSS SP67, API 609
- Temperature limits with sealing seats in:
 - EPDM from -20 °C to +110 °C (with peaks up to +130 °C)
 - NBR from -20 °C to + 90 °C (with peaks up to +100 °C)
 - VITON from -10 °C to + 160 °C
- Maximum working pressure with actuator:
 - PN 16 from DN 40 to DN 200, PN 10 from DN 250 to DN 300
- For general applications and special versions see technical table of manual valve
- In the below table the part number and the valve code refer to the standard valve in GGG40, with seats in EPDM.



DVGW GAS
CERTIFICATION VALVE
NR NG-4313AU2364



SIZE	PART NUMBER	weight in gr.	A	B	C	D	E	F	G	L	P	M	ACTUATOR code	VALVE code	MOUNTING KIT code
1 1/2"	DB7AA60800	4000	133	70	88	40	85	248	59	40	10	90	DGA063AX00	VB326Y608	KANX0008
2"	DB7AA60900	4200	133	70	88	40	92	258	64	43	11	90	DGA063AX00	VB326Y609	KANX0008
2 1/2"	DB7AA61000	5350	133	70	88	40	107	265	72	46	11	90	DGA063AX00	VB326Y610	KANX0008
3"	DB7AA61100	6250	132	83	100	40	122	296	85	46	11	90	DGA075AX00	VB326Y611	KANX0008
4"	DB7AA61200	7100	182	91	108	40	150	318	95	52	11	90	DGA083AX00	VB326Y612	KANX0008
5"	DB7AA61300	9500	203	100	117	40	179	342	110	56	12	90	DGA092AX00	VB326Y613	KANX0008
6"	DB7AA61400	12550	222	120	140	40	206	383	123	56	12	90	DNA110AX00	VB326Y614	KANX0008
8"	DB7AA61500	20650	300	137	127	40	257	405	168	60	13	90	DNA127AX00	VB326Y615	KANX0008
10"	DB7AA61600	26100	380	172	198	50	316	518	203	68	15	125	DNA160AX00	VB326Y616	KANX0016
12"	DB7AA61700	36100	380	172	198	50	370	558	242	78	15	125	DNA160AX00	VB326Y617	KANX0016

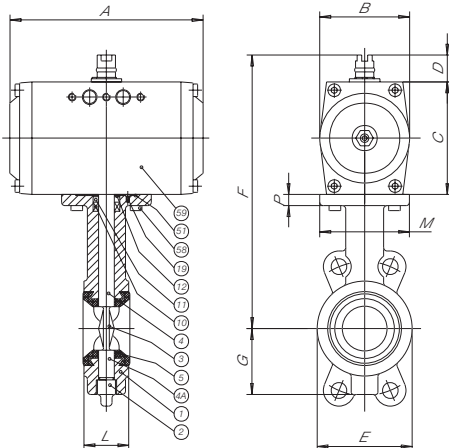

LIST OF VALVE COMPONENTS AND MATERIALS

REF.	PART	Q.ty	MATERIAL
1	BODY	1	DUCTILE IRON GGG40/ASTM A536
2	PLUG	1	NICKEL PLATED C.S.
3	DISC	1	CF8 (AISI 304)
4	STEM	1	TYPE 410
4A	LOWER STEM	1	TYPE 410
5	SEAT	1	EPDM or NBR
10	UPPER SEAL	1	EPDM or NBR
11	BUSHING	1	DELNIN
12	RING	1	STEEL FOR SPRINGS
19	SCREW	2	NICKEL PLATED C.S.
51	WASHER	1	NICKEL PLATED C.S.
58	ACTUATOR SCREW	4	8.8
59	ACTUATOR	1	

Actuator connections: 1/8" G. type from DGA052 to DGA092
1/4" G. Nomur type from DNA110 to DNA255 and DNA045
For accessories see relevant catalogue sheet

ATLANTIS 40

ACTUATOR FEATURES

- Rotation angle: 90°
- Standard version for temperature between -20°C and + 90°C
- Supply maximum pressure: 10 bar
- Nominal pressure: 5,62 bar
- Supply medium: dry filtered compressed air, not necessarily lubricated
- Lubrication: in such a case use a non-detergent or NBR compatible oil
- STANDARD: SPRING CLOSURES/AIR OPENS, clockwise automatic closing

STANDARD VALVE FEATURES

- General prescriptions: BS 5155, MSS SP67, API 609
- Temperature limits with sealing seats in: EPDM from -20 °C to +110 °C (with peaks up to +130 °C)
NBR from -20 °C to + 90 °C (with peaks up to +100 °C)
VITON from -10 °C to + 160 °C
- Maximum working pressure with actuator:
PN 16 from DN 40 to DN 200, PN 10 from DN 250 to DN 300
- For general applications and special versions see technical table of manual valve
- In the below table the part number and the valve code refer to the standard valve in GGG40, with seats in EPDM.



DVGW GAS
CERTIFICATION VALVE
NR NG-4313AU2364



SIZE	PART NUMBER	weight in gr.	A	B	C	D	E	F	G	L	P	M	ACTUATOR code	VALVE code	MOUNTING KIT code
1 1/2"	SB7AA60900	4835	132	83	100	40	85	260	59	40	10	90	SGA0754X00	VB32Y608	KANX0008
2"	SB7AA60900	5620	182	91	108	40	92	278	64	43	11	90	SGA0834X00	VB32Y609	KANX0008
2 1/2"	SB7AA61000	7650	203	100	117	40	107	294	72	46	11	90	SGA0924X00	VB32Y610	KANX0008
3"	SB7AA61100	9765	222	120	140	40	122	336	85	46	11	90	SNA1104X00	VB32Y611	KANX0008
4"	SB7AA61200	10070	222	120	140	40	150	350	95	52	11	90	SNA1104X00	VB32Y612	KANX0008
5"	SB7AA61300	15780	300	137	160	40	179	385	110	56	12	90	SNA1274X00	VB32Y613	KANX0008
6"	SB7AA61400	26385	380	172	198	50	206	451	123	56	12	90	SNA1604X00	VB32Y614	KAPX0014
8"	SB7AA61500	49250	450	224	255	50	257	543	168	60	13	90	SNA2104X00	VB32Y615	KAPX0015
10"	SB7AA61600	49700	450	224	255	50	316	575	203	68	15	125	SNA2104X00	VB32Y616	KAPX0016
12"	SB7AA61700	95770	603	272	302	50	370	662	242	78	15	125	SNA2544X00	VB32Y617	KAPX0017

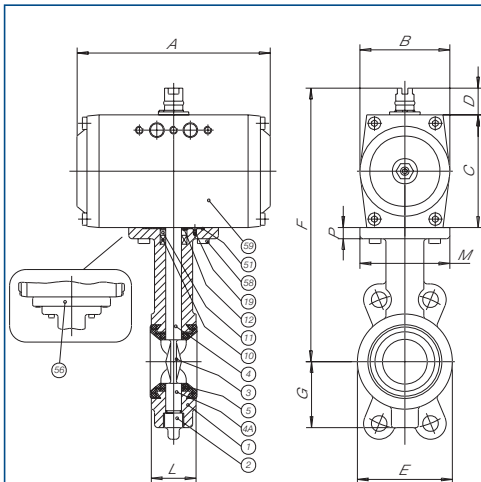

LIST OF VALVE COMPONENTS AND MATERIALS

REF.	PART	Q.ty	MATERIAL
1	BODY	1	DUCTILE IRON GGG40/ASTM A536
2	PLUG	1	NICKEL PLATED C.S.
3	DISC	1	CF8 (AISI 304)
4	STEM	1	TYPE 410
4A	LOWER STEM	1	TYPE 410
5	SEAT	1	EPDM or NBR
10	UPPER SEAL	1	EPDM or NBR
11	BUSHING	1	DELTRIN
12	RING	1	STEEL FOR SPRINGS
19	SCREW	2	NICKEL PLATED C.S.
51	WASHER	1	NICKEL PLATED C.S.
56	BRACKET	1	C.S.
57	BRACKET/VALVE SCREW	4	8.8
58	ACTUATOR SCREW	4	8.8
59	ACTUATOR	1	

Bracket with screws only from DN150 to DN300

Actuator connections: 1/8" G type from SGA052 to SGA092
1/4" G. Namur type from SNA110 to SNA255
and SNA045

For accessories see relevant catalogue sheet

POLARIS

MAIN STANDARD FEATURES

- CONSTRUCTION :
BODY IN CAST IRON: GG25/ASTM A 126-B
DISC IN STAINLESS STEEL: ASTM A316 CF8 (AISI 304)
- General prescriptions: BS 5155 - MSS SP67 - API 609
- DIAMETER: from DN 40 to DN 600
- CONNECTION with flanges:
PN10-PN16 from DN40 to DN150
PN10 from DN200 to DN600
- Maximum working pressure (at pipe end):
PN 16 from DN 40 to DN 150
PN 10 from DN 200 to DN 600
- TEMPERATURE LIMITS WITH SEALING SEATS IN:
EPDM from -20°C to +110°C (with peaks up to + 130 °C)
NBR from -20°C to + 90°C (with peaks up to +100°C)
VITON from -10°C to +160°C
- FACE TO FACE DIMENSIONS in conformity with:
BS 5155 - ISO 5752 - MSS SP 67 - API 609 - DIN 3202/3-K1
- Top flange with ISO 5211 connection
- BLOW-OUT PROOF stem
- OPERATION device: lever handle from DN40 to DN200
manual reduction gear from DN250 to DN600
- Tests: hydraulic on body: 1.5 x nominal pressure
hydraulic for sealing: 1.1 x nominal pressure
pneumatic for sealing: 6 bar
- Locking device from DN40 to DN200
- Tested for vacuum: 1 - 10⁻⁷ bar
- Polyurethanic coating

SPECIAL EXECUTIONS

- ANSI 150 from DN40 to DN600
- Carbon steel body ASTM A216 WCB DN40 + 300
- Yellow lever handle for gas
- Reduction gear with manual operation also for small DN
- Disc in AISI 316
- Disco GGG40 nickel plated fill DN300
- VITON seals
- For further special requests please consult our technical/commercial service

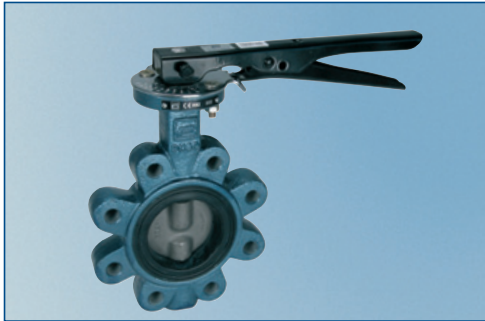

STANDARD PART NUMBERS **Art. B201** with EPDM **Art. B202** with NBR

SCREWS DIMENSIONS



SIZE	PN10 Flanging		PN16 Flanging	
	Ø x Length	holes	Ø x Length	holes
1 1/2"	40 M16 x 30	4	M16 x 30	4
2"	50 M16 x 35	4	M16 x 35	4
2 1/2"	65 M16 x 35	4	M16 x 35	4
3"	80 M16 x 35	8	M16 x 35	8
4"	100 M16 x 40	8	M16 x 40	8
5"	125 M16 x 45	8	M16 x 45	8
6"	150 M20 x 45	8	M20 x 45	8
8"	200 M20 x 50	8	M20 x 50	12
10"	250 M20 x 55	12	M24 x 55	12
12"	300 M20 x 60	12	M24 x 60	12
14"	350 M20 x 60	16	M24 x 60	16
16"	400 M24 x 70	16	M27 x 70	16
20"	500 M24 x 80	20	M30 x 80	20
24"	600 M27 x 90	20	M33 x 90	20

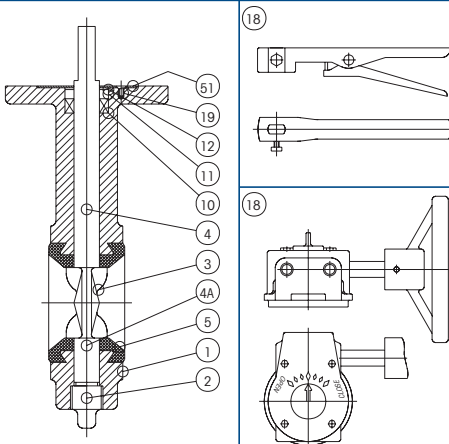

	APPLICATION FOR:	NOT RECOMMENDED FOR:
with EPDM	Water, steam, brine, esters, alcohols, ketones, caustic sodas, abrasive substances, food compounds, phosphates, inorganic acids, etc.	Hydrocarbons, oils, greases, dry air.
with NBR	Natural gas, air, oils and greases.	Solvents, benzene, xylol.
VITON	Mineral oil, benzene, oil for hydraulic purposes and high temperatures, sulphuric acid, propane.	Not recommended for glycolytic fluids, vegetable oil, acetone ethylic acetate, acetic acid.

LIST OF VALVE COMPONENTS AND MATERIALS

REF.	PART	Q.ty	MATERIAL
1	BODY	1	CAST IRON GG25/ASTM A126-B
2	PLUG	1	NICKEL PLATED C. STEEL
3	DISC	1	CF8 (AISI 304)
4	STEM	1	TYPE 410
4A	LOWER STEM	1	TYPE 410
5	SEAT	1	EPDM or NBR
10	UPPER SEAL	1	EPDM or NBR
11	BUSHING	1	DELIRIN
12	RING	1	STEEL FOR SPRINGS
19	SCREW	2	NICKEL PLATED C. STEEL
51	WASHER	1	NICKEL PLATED C. STEEL
18	LEVER HANDLE	1	CARBON STEEL
18	REDUCTION GEAR	1	CAST IRON

POLARIS

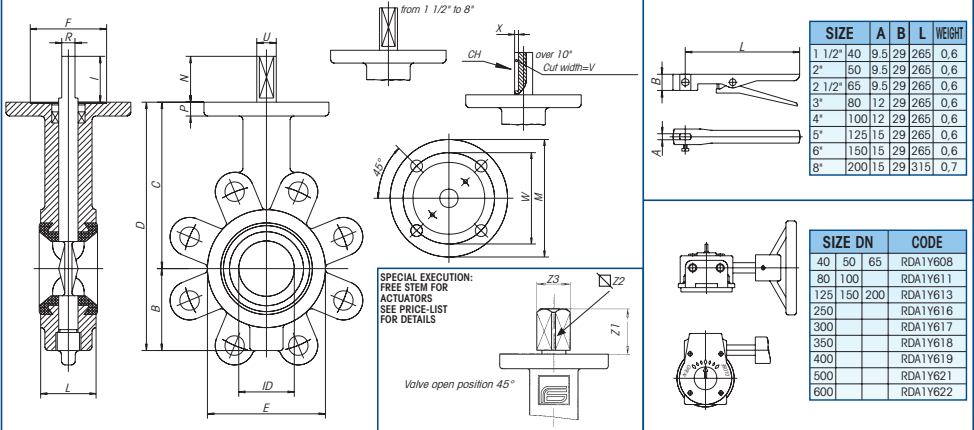

SIZE	STEM																ISO 5211 CONNECT.						*				
	ID	L	B	C	D	E	P	N	I	R	U	X	V	Z1	Z2	Z3	CH	ISO CONN.	M	W	n	Q		F	WEIGHT		
1 1/2"	40	35	40	59	120	179	85	10	33	30	9.5	14					16.5	11	14	F07	90	70	4	9	55	2.7	
2"	50	48	43	64	130	194	92	11	33	30	9.5	14					16.5	11	14	F07	90	70	4	9	55	2.9	
2 1/2"	65	60	46	72	137	209	107	11	33	30	9.5	14					16.5	11	14	F07	90	70	4	9	55	4.1	
3"	80	73	46	85	156	241	122	11	33	30	11.8	16					17.5	11	14	F07	90	70	4	9	55	4.4	
4"	100	100	52	95	170	265	150	11	33	30	11.8	16					17.5	11	14	F07	90	70	4	9	55	4.7	
5"	125	125	56	110	185	295	179	12	33	30	14.5	19					17.5	14	18	F07	90	70	4	9	55	6.3	
6"	150	145	56	123	203	326	206	12	33	30	14.5	19					22.5	14	18	F07	90	70	4	9	55	7.9	
8"	200	190	60	168	238	406	257	13	33	30	14.5	19					22.5	17	22	F07	90	70	4	9	55	12.3	
10"	250	240	68	203	270	473	316	15	65	60			22	4	8		27	22	28	8x7	F10	125	102	4	12	72	19.5
12"	300	290	78	242	310	552	370	15	65	60			28	4	8		27	22	28	8x7	F10	125	102	4	12	72	30.5
14"	350	337	78	290	330	620	410	15	65	60			28	4	8					8x7	F10	125	102	4	12	72	41
16"	400	387	102	330	375	705	468	20	75	70			38	5	12					12x8	F14	175	140	4	18	80	62
20"	500	487	127	400	440	840	578	20	100	95			45	5.5	14					14x9	F16	210	165	4	22	90	111
24"	600	575	154	460	510	970	680	22	100	95			55	5.5	14					14x9	F16	210	165	4	22	105	210

* WEIGHT REFERS TO VALVE WITH BARE SHAFT

BREAKAWAY TORQUES IN Nm

PN - bar	DN size		40	50	65	80	100	125	150	200	250	300	350	400	600
	1 1/2"	2"	2 1/2"	3"	4"	5"	6"	8"	10"	12"	14"	16"	20"	24"	
0	11	14	18	27	40	59	88	157	248	343	485	662	1142	2385	
6	11	20	25	32	41	62	92	173	275	382	549	766	1327	2787	
10	12	23	27	34	54	71	106	186	321	576	680	882	1634	3250	
16	14	25	29	37	56	86	123	262	392	551	1528	2035	3070	5670	

The values in Nm may vary as a function of the seals material, temperature and type of medium. For a firm operation of the various types of actuators, in the different working conditions it is necessary to consider a safety factor of 1.5. During operation, with frequent open and close cycles, the operating torque can decrease considerably in comparison with the initial breakaway torque.

Kv AND Cv VALUES AS A FUNCTION OF OPENING ANGLE

SIZE	Kv AND Cv VALUES AS A FUNCTION OF OPENING ANGLE																
	20°		30°		40°		50°		60°		70°		80°		90°		
	Kv	Cv	Kv	Cv	Kv	Cv	Kv	Cv	Kv	Cv	Kv	Cv	Kv	Cv	Kv	Cv	
1 1/2"	40	2.6	3	4.3	5	9.5	11	16	18	22	26	39	45	60	70	69	80
2"	50	6.7	8	7.8	9	16	18	24	28	48	55	62	72	95	110	116	135
2 1/2"	65	8.6	10	13	15	23	27	38	44	73	85	95	110	145	168	181	210
3"	80	13	15	20	23	34	39	56	65	112	130	142	165	216	250	267	310
4"	100	23	27	35	41	61	71	99	115	198	230	259	300	401	465	466	540
5"	125	50	58	74	86	129	150	211	245	414	480	526	610	845	980	948	1100
6"	150	83	96	121	140	211	245	345	400	677	785	871	1010	1392	1615	1647	1910
8"	200	142	165	211	245	354	410	591	685	1099	1275	1478	1715	2302	2670	2746	3185
10"	250	220	255	328	380	560	650	974	1130	1810	2100	2328	2700	3664	4250	4224	4900
12"	300	319	370	466	540	819	950	1353	1570	2629	3050	3405	3950	5129	5950	6336	7350
14"	350	388	450	647	750	1120	1300	1905	2210	3517	4080	4836	5610	6964	8078	9655	11200
16"	400	552	640	776	900	1483	1720	2405	2790	4310	5000	6336	7650	9284	10770	11121	12900
20"	500	785	910	1375	1595	2457	2850	3991	4630	7414	8600	9914	11500	15121	17540	19310	22400
24"	600	1078	1250	1974	2290	3448	4000	5250	6090	10776	12500	14224	16500	20336	23590	24397	28300

POLARIS 40

MAIN STANDARD FEATURES

- CONSTRUCTION :
BODY IN CAST IRON: GGG40/ASTM 536
DISC IN STAINLESS STEEL: ASTM A351 CF8 (AISI 304)
- General prescriptions: BS 5155 - MSS SP67 - API 609
- DVGW GAS CERTIFICATION
- DIAMETER: from DN 40 to DN 600
- CONNECTIONS with flanges:
PN10-PN16 from DN40 to DN150
PN10 from DN200 to DN600
- Maximum working pressure (at pipe end):
PN 16 from DN 40 to DN 150
PN 10 from DN 200 to DN 600
- TEMPERATURE LIMITS WITH SEALING SEATS IN:
NBR from -20°C to + 90°C (with peaks up to + 100°C)
VITON from -10°C to + 160°C
- EPDM seats
- FACE TO FACE DIMENSIONS in conformity with:
BS 5155 - ISO 5752 - MSS SP 67 - API 609 - DIN 3202/3-K1
- Top flange with ISO 5211 connection
- BLOW-OUT PROOF stem
- OPERATION device: lever handle from DN40 to DN200
manual reduction gear from DN250 to DN600
- Tests: hydraulic on body: 1.5 x nominal pressure
hydraulic for sealing: 1.1 x nominal pressure
pneumatic for sealing: 6 bar
- Locking device from DN40 to DN200
- Tested for vacuum: 1 -10⁻⁷ bar
- Polyurethanic coating



DVGW GAS
CERTIFICATION VALVE
NR NG-4313AU2368



STANDARD PART NUMBERS

Art. **B402** with NBR

SCREWS DIMENSIONS

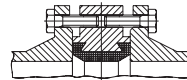

SIZE	PN10 Flanging		PN16 Flanging	
	Ø x Length	holes	Ø x Length	holes
1 1/2"	40	M16 x 30	4	M16 x 30
2"	50	M16 x 35	4	M16 x 35
2 1/2"	65	M16 x 35	4	M16 x 35
3"	80	M16 x 35	8	M16 x 35
4"	100	M16 x 40	8	M16 x 40
5"	125	M16 x 45	8	M16 x 45
6"	150	M20 x 45	8	M20 x 45
8"	200	M20 x 50	8	M20 x 50
10"	250	M20 x 55	12	M24 x 55
12"	300	M20 x 60	12	M24 x 60
14"	350	M20 x 60	16	M24 x 60
16"	400	M24 x 70	16	M27 x 70
20"	500	M24 x 80	20	M30 x 80
24"	600	M27 x 90	20	M33 x 90

SPECIAL EXECUTIONS

- ANSI 150 from DN40 to DN600
- Black lever handle
- Reduction gear with manual operation also for small DN
- Disc in AISI 316
- VITON seats
- For further special requests please consult our technical/commercial service

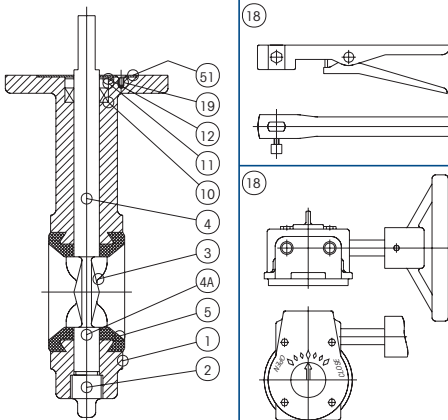

APPLICATION FOR:

with NBR Natural gas, air, oils and greases.

NOT RECOMMENDED FOR:

Solvents, benzene, xylol.

LIST OF VALVE COMPONENTS AND MATERIALS

REF. PART	Q.ty	MATERIAL
1 BODY	1	DUCTILE IRON GGG40/ASTM A536
2 PLUG	1	NICKEL PLATED C. STEEL
3 DISC	1	CF8 (AISI 304)
4 STEM	1	TYPE 410
4A LOWER STEM	1	TYPE 410
5 SEAT	1	EPDM or NBR
10 UPPER SEAL	1	EPDM or NBR
11 BUSHING	1	DELTRIN
12 RING	1	STEEL FOR SPRINGS
19 SCREW	2	NICKEL PLATED C. STEEL
51 WASHER	1	NICKEL PLATED C. STEEL
18 LEVER HANDLE	1	CARBON STEEL
18 REDUCTION GEAR	1	CAST IRON

POLARIS 40

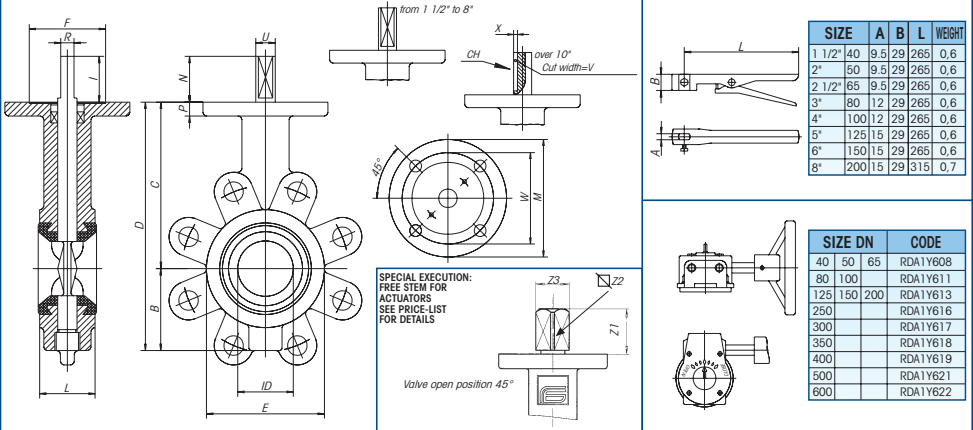

SIZE	STEM																	ISO 5211 CONNECT.							*	
	ID	L	B	C	D	E	P	N	I	R	U	X	V	Z1	Z2	Z3	CH	ISO CONN.	M	W	n	Q	F	WEIGHT		
1 1/2"	40	35	40	59	120	179	85	10	33	30	9.5	14					16.5	11	14	F07	90	70	4	9	55	2.7
2"	50	48	43	64	130	194	92	11	33	30	9.5	14					16.5	11	14	F07	90	70	4	9	55	2.9
2 1/2"	65	60	46	72	137	209	107	11	33	30	9.5	14					16.5	11	14	F07	90	70	4	9	55	4.1
3"	80	73	46	85	156	241	122	11	33	30	11.8	16					17.5	11	14	F07	90	70	4	9	55	4.4
4"	100	100	52	95	170	265	150	11	33	30	11.8	16					17.5	11	14	F07	90	70	4	9	55	4.7
5"	125	125	56	110	185	295	179	12	33	30	14.5	19					17.5	14	18	F07	90	70	4	9	55	6.3
6"	150	145	56	123	203	326	206	12	33	30	14.5	19					22.5	14	18	F07	90	70	4	9	55	7.9
8"	200	190	60	168	238	406	257	13	33	30	14.5	19					22.5	17	22	F07	90	70	4	9	55	12.3
10"	250	240	68	203	270	473	316	15	65	60		22	4	8		27	22	28	8x7	F10	125	102	4	12	72	19.5
12"	300	290	78	242	310	552	370	15	65	60		28	4	8		27	22	28	8x7	F10	125	102	4	12	72	30.5
14"	350	337	78	290	330	620	410	15	65	60		28	4	8				8x7	F10	125	102	4	12	72	41	
16"	400	387	102	330	375	705	468	20	75	70		38	5	12				12x8	F14	175	140	4	18	80	62	
20"	500	487	127	400	440	840	578	20	100	95		45	5.5	14				14x9	F16	210	165	4	22	90	111	
24"	600	575	154	460	510	970	680	22	100	95		55	5.5	14				14x9	F16	210	165	4	22	105	210	

* WEIGHT REFERS TO VALVE WITH BARE SHAFT

BREAKAWAY TORQUES in Nm

DN size	1 1/2"	2"	2 1/2"	3"	4"	5"	6"	8"	10"	12"	14"	16"	20"	24"	
PN - bar	0	11	14	18	27	40	59	88	157	248	343	485	662	1142	2385
	6	11	20	25	32	41	62	92	173	275	382	549	766	1327	2787
	10	12	23	27	34	54	71	106	186	321	576	680	882	1634	3250
	16	14	25	29	37	56	86	123	262	392	551	1528	2035	3070	5670

The values in Nm may vary as a function of the seals material, temperature and type of medium. For a firm operation of the various types of actuators, in the different working conditions it is necessary to consider a safety factor of 1.5. During operation, with frequent open and close cycles, the operating torque can decrease considerably in comparison with the initial breakaway torque.

Kv AND Cv VALUES AS A FUNCTION OF OPENING ANGLE

SIZE	20°		30°		40°		50°		60°		70°		80°		90°		
	Kv	Cv	Kv	Cv	Kv	Cv	Kv	Cv	Kv	Cv	Kv	Cv	Kv	Cv	Kv	Cv	
	1 1/2"	40	2.6	3	4.3	5	9.5	11	16	18	22	26	39	45	60	70	69
2"	50	6.7	8	7.8	9	16	18	24	28	48	55	62	72	95	110	116	135
2 1/2"	65	8.6	10	13	15	23	27	38	44	73	85	95	110	145	168	181	210
3"	80	13	15	20	23	34	39	56	65	112	130	142	165	216	250	267	310
4"	100	23	27	35	41	61	71	99	115	198	230	259	300	401	465	466	540
5"	125	50	58	74	86	129	150	211	245	414	480	526	610	845	980	948	1100
6"	150	83	96	121	140	211	245	345	400	677	785	871	1010	1392	1615	1647	1910
8"	200	142	165	211	245	354	410	591	685	1099	1275	1478	1715	2302	2670	2746	3185
10"	250	220	255	328	380	560	650	974	1130	1810	2100	2328	2700	3664	4250	4224	4900
12"	300	319	370	466	540	819	950	1353	1570	2629	3050	3405	3950	5129	5950	6336	7350
14"	350	388	450	647	750	1120	1300	1905	2210	3517	4080	4836	5610	6964	8078	9655	11200
16"	400	552	640	776	900	1483	1720	2405	2790	4310	5000	6336	7650	9284	10770	11121	12900
20"	500	785	910	1375	1595	2457	2850	3991	4630	7414	8600	9914	11500	15121	17540	19310	22400
24"	600	1078	1250	1974	2290	3448	4000	5250	6090	10776	12500	14224	16500	20336	23590	24397	28300

POLARIS

ACTUATOR FEATURES

- Rotation angle: 90°
- Standard version for temperature between -20°C and + 90°C
- Supply maximum pressure: 10 bar
- Nominal pressure: 5,62 bar
- Supply medium: dry filtered compressed air, not necessarily lubricated
- Lubrication: in such a case use a non-detergent or NBR compatible oil

STANDARD VALVE FEATURES

- General prescriptions: BS 5155, MSS SP67, API 609
- Temperature limits with sealing seats in:
EPDM from -20 °C to +110 °C (with peaks up to +130 °C)
NBR from -20 °C to + 90 °C (with peaks up to +100 °C)
VITON from -10 °C to + 160 °C.
- Maximum working pressure with actuator (at pipe end)
PN 16 from DN 40 to DN 150, PN 10 from DN 200 to DN 300
- For general applications and special versions see technical table of manual valve
- In the below table the part number and the valve code refer to the standard valve in GG25, with seats in EPDM.



SIZE	PART NUMBER	weight in gr.	A	B	C	D	E	F	G	L	P	M	ACTUATOR code	VALVE code	MOUNTING KIT code
1 1/2"	40 DB2AA60800	5000	133	70	88	40	85	248	59	40	10	90	DGA063AX00	VB21Y608	KANX0008
2"	50 DB2AA60900	5500	133	70	88	40	92	258	64	43	11	90	DGA063AX00	VB21Y609	KANX0008
2 1/2"	65 DB2AA61000	6950	133	70	88	40	107	265	72	46	11	90	DGA063AX00	VB21Y610	KANX0008
3"	80 DB2AA61100	10550	132	83	100	40	122	296	85	46	11	90	DGA075AX00	VB21Y611	KANX0008
4"	100 DB2AA61200	11600	182	91	108	40	150	318	95	52	11	90	DGA083AX00	VB21Y612	KANX0008
5"	125 DB2AA61300	15900	203	100	117	40	179	342	110	56	12	90	DGA092AX00	VB21Y613	KANX0008
6"	150 DB2AA61400	18350	222	120	140	40	206	383	123	56	12	90	DNA110AX00	VB21Y614	KANX0008
8"	200 DB2AA61500	30350	300	137	127	40	257	405	168	60	13	90	DNA127AX00	VB21Y615	KANX0008
10"	250 DB2AA61600	36600	380	172	198	50	316	518	203	68	15	125	DNA160AX00	VB21Y616	KANX0016
12"	300 DB2AA61700	50600	380	172	198	50	370	558	242	78	15	125	DNA160AX00	VB21Y617	KANX0016

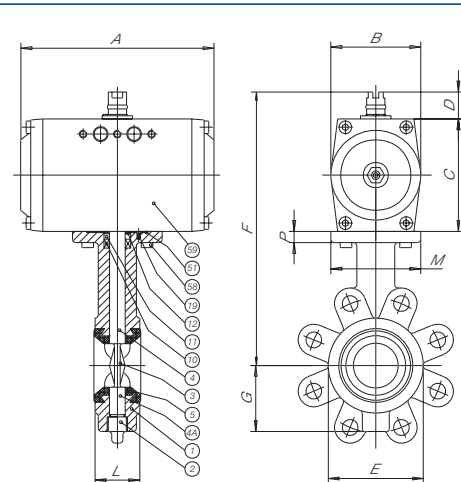

LIST OF VALVE COMPONENTS AND MATERIALS

REF.	PART	Q.ty	MATERIAL
1	BODY	1	CAST IRON GG25/ASTM A126-B
2	PLUG	1	NICKEL PLATED C.S.
3	DISC	1	CF8 (AISI 304)
4	STEM	1	TYPE 410
4A	LOWER STEM	1	TYPE 410
5	SEAT	1	EPDM or NBR
10	UPPER SEAL	1	EPDM or NBR
11	BUSHING	1	DELTRIN
12	RING	1	STEEL FOR SPRINGS
19	SCREW	2	NICKEL PLATED C.S.
51	WASHER	1	NICKEL PLATED C.S.
58	ACTUATOR SCREW	4	8.8
59	ACTUATOR	1	

Actuator connections: 1/8" G. type from DGA052 to DGA092
1/4" G. Nomur type from DNA110 to DNA255 and DNA045
For accessories see relevant catalogue sheet

POLARIS

ACTUATOR FEATURES

- Rotation angle: 90°
- Standard version for temperature between –20°C and + 90°C
- Supply maximum pressure: 10 bar
- Nominal pressure: 5,62 bar
- Supply medium: dry filtered compressed air, not necessarily lubricated
- Lubrication: in such a case use a non-detergent or NBR compatible oil
- STANDARD: SPRING CLOSURES/AIR OPENS, clockwise automatic closing

STANDARD VALVE FEATURES

- General prescriptions: BS 5155, MSS SP67, API 609
- Temperature limits with sealing seats in:
EPDM from –20 °C to +110 °C (with peaks up to +130 °C)
NBR from –20 °C to + 90 °C (with peaks up to +100 °C)
VITON from –10 °C to + 160 °C
- Maximum working pressure with actuator (at pipe end)
PN 16 from DN 40 to DN 150, PN 10 from DN 200 to DN 300
- For general applications and special versions see technical table of manual valve
- In the below table the part number and the valve code refer to the standard valve in GG25, with seats in EPDM.



SIZE	PART NUMBER	weight in gr.	A	B	C	D	E	F	G	L	P	M	ACTUATOR code	VALVE code	MOUNTING KIT code
1 1/2"	SB2AA60900	5835	132	83	100	40	85	260	59	40	10	90	SGA0754X00	VB21Y608	KANX0008
2"	SB2AA60900	6920	182	91	108	40	92	278	64	43	11	90	SGA0834X00	VB21Y609	KANX0008
2 1/2"	SB2AA61000	9250	203	100	117	40	107	294	72	46	11	90	SGA0924X00	VB21Y610	KANX0008
3"	SB2AA61100	14065	222	120	140	40	122	336	85	46	11	90	SNA1104X00	VB21Y611	KANX0008
4"	SB2AA61200	14570	222	120	140	40	150	350	95	52	11	90	SNA1104X00	VB21Y612	KANX0008
5"	SB2AA61300	22180	300	137	160	40	179	385	110	56	12	90	SNA1274X00	VS21Y613	KANX0008
6"	SB2AA61400	32185	380	172	198	50	206	451	123	56	12	90	SNA1604X00	VS21Y614	KAPX0014
8"	SB2AA61500	58950	450	224	255	50	257	543	168	60	13	90	SNA2104X00	VS21Y615	KAPX0015
10"	SB2AA61600	60200	450	224	255	50	316	575	203	68	15	125	SNA2104X00	VS21Y616	KAPX0016
12"	SB2AA61700	110270	603	272	302	50	370	662	242	78	15	125	SNA2544X00	VS21Y617	KAPX0017

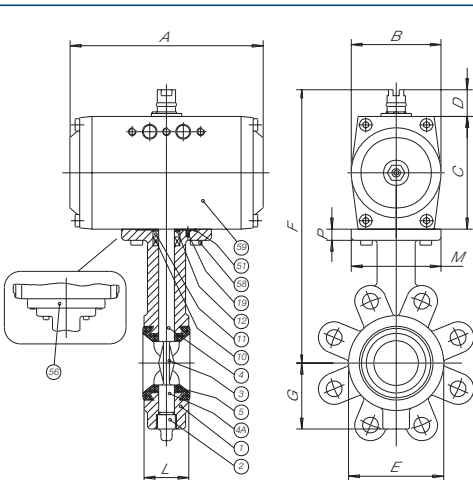

LIST OF VALVE COMPONENTS AND MATERIALS

REF.	PART	Q.ty	MATERIAL
1	BODY	1	CAST IRON GG25/ASTM A126-B
2	PLUG	1	NICKEL PLATED C.S.
3	DISC	1	CF8 (AISI 304)
4	STEM	1	TYPE 410
4A	LOWER STEM	1	TYPE 410
5	SEAT	1	EPDM or NBR
10	UPPER SEAL	1	EPDM or NBR
11	BUSHING	1	DELTRIN
12	RING	1	STEEL FOR SPRINGS
19	SCREW	2	NICKEL PLATED C.S.
51	WASHER	1	NICKEL PLATED C.S.
56	BRACKET	1	C.S.
57	BRACKET/VALVE SCREW	4	8.8
58	ACTUATOR SCREW	4	8.8
59	ACTUATOR	1	

Bracket with screws only from DN150 to DN300

Actuator connections: 1/8" G. type from SGA052 to SGA092
1/4" G. Namur type from SNA110 to SNA255, e SNA045
For accessories see relevant catalogue sheet

POLARIS 40

ACTUATOR FEATURES

- Rotation angle: 90°
- Standard version for temperature between -20°C and + 90°C
- Supply maximum pressure: 10 bar
- Nominal pressure: 5,62 bar
- Supply medium: dry filtered compressed air, not necessarily lubricated
- Lubrication: in such a case use a non-detergent or NBR compatible oil

STANDARD VALVE FEATURES

- General prescriptions: BS 5155, MSS SP67, API 609
- Temperature limits with sealing seats in:
EPDM from -20 °C to +110 °C (with peaks up to +130 °C)
NBR from -20 °C to +90 °C (with peaks up to +100 °C)
VITON from -10 °C to +160 °C.
- Maximum working pressure with actuator (at pipe end)
PN 16 from DN 40 to DN 150, PN 10 from DN 200 to DN 300
- For general applications and special versions see technical table of manual valve
- In the below table the part number and the valve code refer to the standard valve in GGG40, with seats in EPDM.



DVGW GAS
CERTIFICATION VALVE
NR NG-4313AU2368



SIZE	PART NUMBER	weight in gr.	A	B	C	D	E	F	G	L	P	M	ACTUATOR code	VALVE code	MOUNTING KIT code
1 1/2"	DB8AA60800	5000	133	70	88	40	85	248	59	40	10	90	DGA063AX00	VB42Y608	KANX0008
2"	DB8AA60900	5500	133	70	88	40	92	258	64	43	11	90	DGA063AX00	VB42Y609	KANX0008
2 1/2"	DB8AA61000	6950	133	70	88	40	107	265	72	46	11	90	DGA063AX00	VB42Y610	KANX0008
3"	DB8AA61100	10550	132	83	100	40	122	296	85	46	11	90	DGA075AX00	VB42Y611	KANX0008
4"	DB8AA61200	11600	182	91	108	40	150	318	95	52	11	90	DGA083AX00	VB42Y612	KANX0008
5"	DB8AA61300	15900	203	100	117	40	179	342	110	56	12	90	DGA092AX00	VB42Y613	KANX0008
6"	DB8AA61400	18350	222	120	140	40	206	383	123	56	12	90	DNA110AX00	VS42Y614	KANX0008
8"	DB8AA61500	30350	300	137	127	40	257	405	168	60	13	90	DNA127AX00	VS42Y615	KANX0008
10"	DB8AA61600	36600	380	172	198	50	316	518	203	68	15	125	DNA160AX00	VS42Y616	KANX0016
12"	DB8AA61700	50600	380	172	198	50	370	558	242	78	15	125	DNA160AX00	VS42Y617	KANX0016

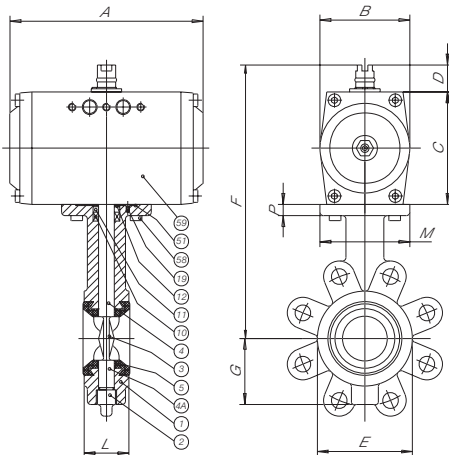

LIST OF VALVE COMPONENTS AND MATERIALS

REF.	PART	Q.ty	MATERIAL
1	BODY	1	DUCTILE IRON GGG40/ASTM A536
2	PLUG	1	NICKEL PLATED C.S.
3	DISC	1	CF8 (AISI 304)
4	STEM	1	TYPE 410
4A	LOWER STEM	1	TYPE 410
5	SEAT	1	EPDM o NBR
10	UPPER SEAL	1	EPDM o NBR
11	BUSHING	1	DELIRIN
12	RING	1	STEEL FOR SPRINGS
19	SCREW	2	NICKEL PLATED C.S.
51	WASHER	1	NICKEL PLATED C.S.
58	ACTUATOR SCREW	4	8.8
59	ACTUATOR	1	

Bracket with screws only from DN150 to DN300

Actuator connections: 1/8" G. type from SGA052 to SGA092

1/4" G. Namur type from SNA110 to SNA255, e SNA045

For accessories see relevant catalogue sheet

POLARIS 40

ACTUATOR FEATURES

- Rotation angle: 90°
- Standard version for temperature between -20°C and + 90°C
- Supply maximum pressure: 10 bar
- Nominal pressure: 5,62 bar
- Supply medium: dry filtered compressed air, not necessarily lubricated
- Lubrication: in such a case use a non-detergent or NBR compatible oil
- STANDARD: SPRING CLOSES/AIR OPENS, clockwise automatic closing

STANDARD VALVE FEATURES

- General prescriptions: BS 5155, MSS SP67, API 609
- Temperature limits with sealing seats in:
EPDM from -20 °C to +110 °C (with peaks up to +130 °C)
NBR from -20 °C to + 90 °C (with peaks up to +100 °C)
VITON from -10 °C to + 160 °C
- Maximum working pressure with actuator (at pipe end)
PN 16 from DN 40 to DN 150, PN 10 from DN 200 to DN 300
- For general applications and special versions see technical table of manual valve
- In the below table the part number and the valve code refer to the standard valve in GGG40, with seats in EPDM.



DVGW GAS
CERTIFICATION VALVE
NR NG-4313AU2368



SIZE	PART NUMBER	weight in gr.	A	B	C	D	E	F	G	L	P	M	ACTUATOR code	VALVE code	MOUNTING KIT code
1 1/2"	40 SB8AA60900	5835	132	83	100	40	85	260	59	40	10	90	SGA0754X00	VB42Y608	KANX0008
2"	50 SB8AA60900	6920	182	91	108	40	92	278	64	43	11	90	SGA0834X00	VB42Y609	KANX0008
2 1/2"	65 SB8AA61000	9250	203	100	117	40	107	294	72	46	11	90	SGA0924X00	VB42Y610	KANX0008
3"	80 SB8AA61100	14065	222	120	140	40	122	336	85	46	11	90	SNA1104X00	VB42Y611	KANX0008
4"	100 SB8AA61200	14570	222	120	140	40	150	350	95	52	11	90	SNA1104X00	VB42Y612	KANX0008
5"	125 SB8AA61300	22180	300	137	160	40	179	385	110	56	12	90	SNA1274X00	VB42Y613	KANX0008
6"	150 SB8AA61400	32185	380	172	198	50	206	451	123	56	12	90	SNA1604X00	VB42Y614	KAPX0014
8"	200 SB8AA61500	58950	450	224	255	50	257	543	168	60	13	90	SNA2104X00	VB42Y615	KAPX0015
10"	250 SB8AA61600	60200	450	224	255	50	316	575	203	68	15	125	SNA2104X00	VB42Y616	KAPX0016
12"	300 SB8AA61700	110270	603	272	302	50	370	662	242	78	15	125	SNA2544X00	VS42Y617	KAPX0017

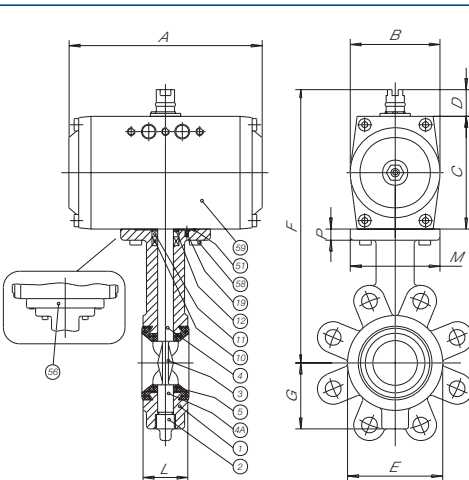

LIST OF VALVE COMPONENTS AND MATERIALS

REF.	PART	Q.ty	MATERIAL
1	BODY	1	DUCTILE IRON GGG40/ASTM A536
2	PLUG	1	NICKEL PLATED C.S.
3	DISC	1	CF8 (AISI 304)
4	STEM	1	TYPE 410
4A	LOWER STEM	1	TYPE 410
5	SEAT	1	EPDM or NBR
10	UPPER SEAL	1	EPDM or NBR
11	BUSHING	1	DELTRIN
12	RING	1	STEEL FOR SPRINGS
19	SCREW	2	NICKEL PLATED C.S.
51	WASHER	1	NICKEL PLATED C.S.
56	BRACKET	1	C.S.
57	BRACKET/VALVE SCREW	4	8.8
58	ACTUATOR SCREW	4	8.8
59	ACTUATOR	1	

Bracket with screws only from DN150 to DN300

Actuator connections: 1/8" G. type from SGA052 to SGA092
1/4" G. Namur type from SNA110 to SNA255, e SNA045
For accessories see relevant catalogue sheet

SUN WP

2-PIECE BALL VALVE—FULL BORE

MAIN STANDARD FEATURES

- CONSTRUCTION: AISI 316
- CERTIFICATIONS: DVGW for gas
TÜV for TA Luft
- DIAMETER: from DN10 - 3/8" to DN 50 - 2"
- PRESSURES: from 160 BAR to 40 BAR
- TEMPERATURE LIMITS: from -20°C to +150°C
- ISO 5211 mounting plate
- BLOW-OUT PROOF stem from 3/4" to 2"
- CONNECTIONS: F/F UNI-ISO 7/1 Rp – DIN 2999 parallel
M/F (male UNI-ISO 7/1 R taper, female parallel)
- WRAPPING SEATS
- TRIPLE stem-packing with labyrinth effect and automatic adjustment by Belleville washers
- NON-WETTED parts in stainless steel
- OPERATION devices: lever
- Tested for vacuum 1-10⁻³ STD CC/SEC



DVGW GAS
APPROVED

STANDARD PART NUMBERS

Art. 2551

female/female

Art. 2552

male/female

SPECIAL EXECUTIONS

- 15% GLASS-FILLED PTFE. Temperature limits -20°C + 175°C
- PTFE+CARBOGRAPHITE: use up to 195°C, for steam up to 180°C
- FEMALE CONNECTIONS: NPT ANSI B1.20.1
- Stems with antistatic device from 3/4" to 2"
- Degreased version
- SUNNY WP valve (SUN WP polished)
- On request the valve is available with ATEX certificate (from 3/4" to 2")
- For further special requests please consult our technical/commercial service

GENERAL APPLICATIONS

Use as an ON-OFF valve for: chemical products, for water and pneumatic installations, gas, water, vacuum. For steam within limited working conditions and with special seals. All parts have to be adequately degreased if the valves have to be used for oxygen.

For special utilizations ascertain the compatibility with process features and the corrosion resistance also by the relevant table.

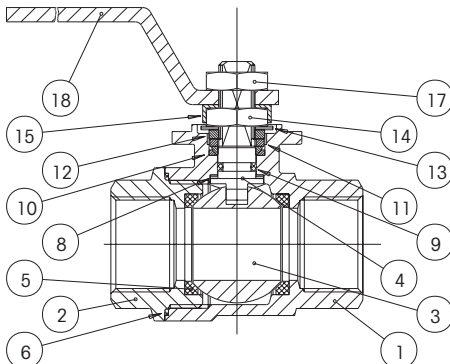

LIST OF COMPONENTS AND MATERIALS

REF.	PART	MATERIAL	DIN MAT.	QTY
1	BODY	AISI 316	1.4408	1
2	FEMALE END	AISI 316	1.4408	1
3	BALL	AISI 316	1.4401	1
4	STEM	AISI 316	1.4401	1
5	SEAT	PTFE	-	2
6	SIDE SEALING RING	PTFE	-	1
8	UPPER SEALING RING	PTFE	-	2
9	STEM O-RING	VITON	-	1
10	UPPER SEALING COUPLE	PTFE	-	1
11	PACKING GLAND	AISI 304	1.4301	1
12	OPERATION STOP	AISI 304	1.4301	1
13	BELLEVILLE WASHERS	AISI 301	1.4310	2
14	STEM RETAINING NUT	AISI 304	1.4301	1
15	FIXING NUT PLATE	AISI 304	1.4301	1
17	LOCKING NUT	AISI 304	1.4301	1
18	LEVER HANDLE	AISI 304	1.4301	1

SUN WP

2-PIECE BALL VALVE—FULL BORE

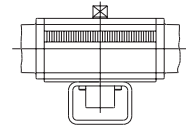
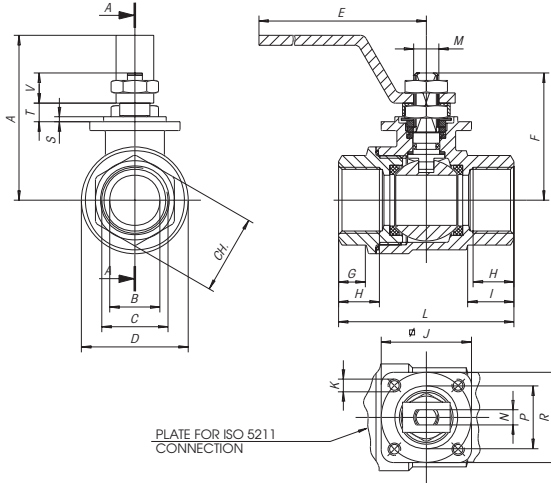

By removing the lever handle, the SUN WP valve can be directly mounted on an actuator by the special bracket with screws, the stem adapter and by replacing the operation stop (part 12) of the valve (kit supplied upon request).



C (inch)	A	B	D	E	F	G	H	I	J	K	L	M	N	P	R	S	T	V	hex. key	oct. key	ISO conn.	weight in gr MF	weight in gr MF
3/8"	52	10	29	110	37	8.5	11.4	13.5	36	M5	50	M8	4	25	36	2	6	9.5	21.5	-	F03	250	235
1/2"	55	15	34	110	42	10	15	18	36	M5	60	M8	4	25	36	2	6	9.5	26.5	-	F03	350	315
3/4"	66	20	42.5	140	52	11.5	16.3	18	36	M5	70	M10	6	25	36	2	7.5	12	31.5	-	F03	565	510
1"	70	25	50.5	140	56	14	19.1	27.5	36	M5	85	M10	6	25	36	2	7.5	12	40.5	-	F03	855	765
1 1/4"	85	32	63	180	68	15.5	21.4	28.5	42	M5	95	M12	8	30	42	3	9.5	13.5	-	49.5	F04	1395	1270
1 1/2"	91	40	75.5	180	74	18.5	21.4	23	42	M5	105	M12	8	30	42	3	9.5	13.5	-	54.5	F04	1945	1810
2"	105	50	91	230	87	22.5	25.7	35	50	M6	125	M16	10	35	50	3	11.3	17.8	-	69.5	F05	3320	3160

BREAKAWAY TORQUES in Nm

DN size	10	15	20	25	32	40	50
3/8"	1.6	3.2	3.6	4.6	11.5	19	27.5
1/2"	1.8	4.3	4.9	5.9	15	24	38
3/4"	2.5	5.1	6	6.9	16.7	28.6	42
1"	3.2	5.6	6.8	8	18.4	32	
1 1/4"	3.8	6.5	8.5	10			
1 1/2"	5	8					

The values in Nm may vary as a function of the seals material, temperature and type of medium. For a firm operation of the various types of actuators, in the different working conditions it is necessary to consider a safety factor of 1.5. During operation, with frequent open and close cycles, the operating torque can decrease considerably in comparison with the initial breakaway torque.

PRESSURE/TEMPERATURE DIAGRAM

At each pressure level corresponds the admissible temperature level.

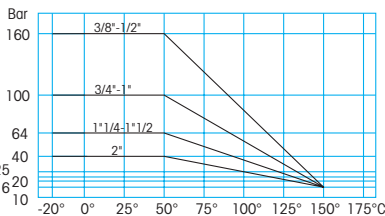

LOSS OF HEAD DIAGRAM/FLOW RATE

The Kv value is the flow rate causing a pressure drop of 1 bar

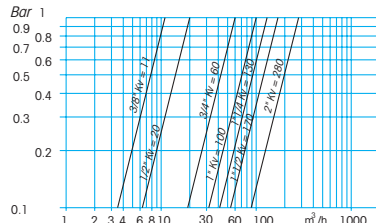

SUN WP

2-PIECE BALL VALVE - FULL BORE WITH **DOUBLE ACTING** PNEUMATIC ACTUATOR

ACTUATOR FEATURES

- Rotation angle: 90°
- Standard version for temperature between -20°C and + 90°C
- Supply maximum pressure: 10 bar (8bar for DNA045)
- Nominal pressure: 5,62 bar
- Supply medium: dry filtered compressed air, not necessarily lubricated
- Lubrication: in such a case use a non-detergent or NBR compatible oil

STANDARD VALVE FEATURES

- Working temperature: from -20°C to +150°C
- Maximum working pressure with actuator: from 160 bar to 40 bar
- CONNECTIONS: F/F UNI-ISO 7/1 Rp - DIN 2999 parallel
M/F (male UNI-ISO 7/1 R taper, female parallel)
- BLOW-OUT PROOF stem from 3/4" to 2"
- ISO 5211 mounting plate
- For general applications and special versions see technical table of manual valve
- In the below table the part number and the valve code refer to the standard valve female/female



SIZE	PART NUMBER	weight in gr.	A	B	C	E	F	CH mm:	CH inch:	L	M	ACTUATOR code	VALVE code	MOUNTING KIT code
3/8"	D31AA20300	808	110	53	68	14.5	157.5	21.5	-	50	29	DNA045AZ00	V400H203	K1GA0003
1/2"	D31AA20400	895	110	53	68	17	162.5	26.5	-	60	34	DNA045AZ00	V400H204	K1GA0003
3/4"	D31AA20500	1110	110	53	68	21.5	168.5	31.5	-	70	42.5	DNA045AZ00	V400H205	K1GA0105
1"	D31AA20600	1720	127	59	74	25.5	188.5	40.5	-	85	50.5	DGA052AX00	V400H206	K1GA0206
1 1/4"	D31AA20700	2880	133	70	88	31.5	220	-	49.5	95	63	DGA063AX00	V400H207	K1GA0207
1 1/2"	D31AA20800	4135	132	83	100	38	238	-	54.5	105	75.5	DGA075AX00	V400H208	K1GA0208
2"	D31AA20900	5620	132	83	100	46	245	-	69.5	125	91	DGA075AX00	V400H209	K1GA0009

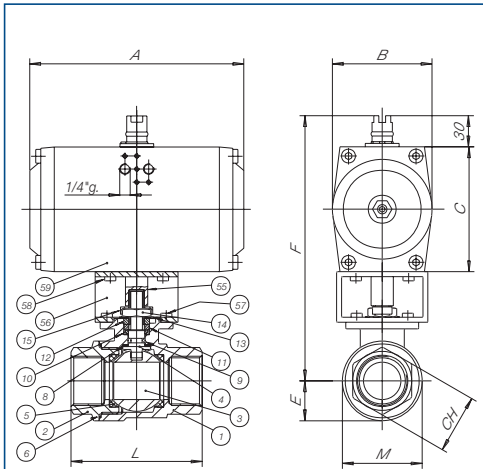

LIST OF VALVE COMPONENTS AND MATERIALS

REF.	PART	QTY	MATERIAL
1	BODY	1	ALSI 316
2	FEMALE END	1	ALSI 316
3	BALL	1	ALSI 316
4	STEM	1	ALSI 316
5	SEAT	2	PTFE
6	SIDE SEALING RING	1	PTFE
8	UPPER SEALING RING	1	PTFE
9	STEM O-RING	1	VITON
10	UPPER SEALING COUPLE	1	PTFE
11	PACKING GLAND	1	ALSI 304
12	WASHER	1	ALSI 304
13	BELLEVILLE WASHERS	2	ALSI 301
14	STEM RETAINING NUT	1	ALSI 304
15	FIXING NUT PLATE	1	ALSI 304
55	ACTUATOR SHAFT	1	C.S.
56	BRACKET	1	C.S.
57	BRACKET/VALVE SCREW	4	8.8
58	BRACKET/ACTUATOR SCREW	4	8.8
59	ACTUATOR	1	

For accessories see relevant catalogue sheet

SUN WP

2-PIECE BALL VALVE - FULL BORE WITH **SPRING RETURN PNEUMATIC ACTUATOR**

ACTUATOR FEATURES

- Rotation angle: 90°
- Standard version for temperature between -20°C and + 90°C
- Supply maximum pressure: 10 bar (8bar for SNA045)
- Nominal pressure: 5,62 bar
- Supply medium: dry filtered compressed air, not necessarily lubricated
- Lubrication: in such a case use a non-detergent or NBR compatible oil
- STANDARD: **SPRING CLOSES/AIR OPENS**, clockwise automatic closing

STANDARD VALVE FEATURES

- Temperature limits: from -20°C to +150°C
- Maximum working pressure with actuator: from 160 bar to 40 bar
- CONNECTIONS: F/F UNI-ISO 7/1 Rp – DIN 2999 parallel
M/F (male UNI-ISO 7/1 R taper, female parallel)
- BLOW-OUT PROOF stem from 3/4" to 2"
- ISO 5211 mounting plate
- For general applications and special versions see technical table of manual valve
- In the below table the part number and the valve code refer to the standard valve female/female

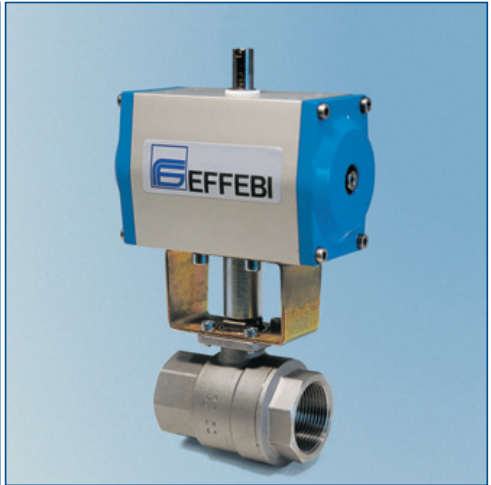

SIZE	PART NUMBER	weight in gr.	A	B	C	E	F	CH inns.	CH outb.	L	M	ACTUATOR code	VALVE code	Mounting kit code
3/8"	S31AA20300	880	110	53	68	14.5	157.5	21.5	-	50	29	SNA0452W00	V400H203	K1GA0003
1/2"	S31AA20400	1375	127	59	74	17	178.5	26.5	-	60	34	SGA0524X00	V400H204	K1GA0204
3/4"	S31AA20500	1590	127	59	74	21.5	184.5	31.5	-	70	42.5	SGA0524X00	V400H205	K1GA0205
1"	S31AA20600	2475	133	70	88	25.5	202.5	40.5	-	85	50.5	SGA0634X00	V400H206	K1GA0306
1 1/4"	S31AA20700	3800	132	83	100	31.5	232	-	49.5	95	63	SGA0754X00	V400H207	K1GA0307
1 1/2"	S31AA20800	6000	203	100	117	38	255	-	54.5	105	75.5	SGA0924X00	V400H208	K1GA0208
2"	S31AA20900	9490	222	120	140	46	285	-	69.5	125	91	SGA1104X00	V400H209	K1GA0109

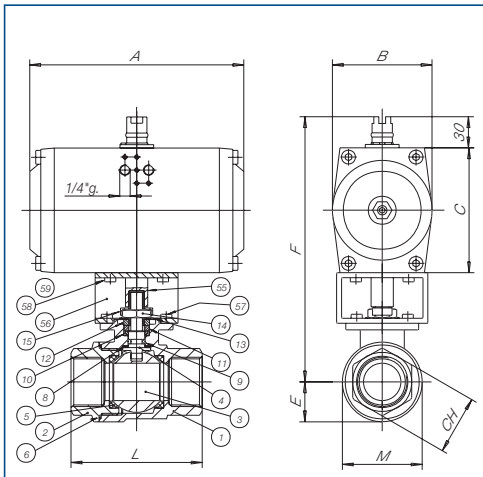

LIST OF VALVE COMPONENTS AND MATERIALS

REF.	PART	QTY	MATERIAL
1	BODY	1	AlSi 316
2	FEMALE END	1	AlSi 316
3	BALL	1	AlSi 316
4	STEM	1	AlSi 316
5	SEAT	2	PTFE
6	SIDE SEALING RING	1	PTFE
8	UPPER SEALING RING	1	PTFE
9	STEM O-RING	1	VITON
10	UPPER SEALING COUPLE	1	PTFE
11	PACKING GLAND	1	AlSi 304
12	WASHER	1	AlSi 304
13	BELLEVILLE WASHERS	2	AlSi 301
14	STEM RETAINING NUT	1	AlSi 304
15	FIXING NUT PLATE	1	AlSi 304
55	ACTUATOR SHAFT	1	C.S.
56	BRACKET	1	C.S.
57	BRACKET/VALVE SCREW	4	8.8
58	BRACKET/ACTUATOR SCREW	4	8.8
59	ACTUATOR	1	

For accessories see relevant catalogue sheet

VEGA

2-PIECE BALL VALVE - FULL BORE WITH ISO TOP, WITH **DOUBLE ACTING** PNEUMATIC ACTUATOR

ACTUATOR FEATURES

- Rotation angle: 90°
- Standard version for temperature between -20°C and + 90°C
- Supply maximum pressure: 10 bar (8bar for DNA045)
- Nominal pressure: 5,62 bar
- Supply medium: dry filtered compressed air, not necessarily lubricated
- Lubrication: in such a case use a non-detergent or NBR compatible oil

STANDARD VALVE FEATURES

- Temperature limits: from -20°C to +150°C
- Maximum working pressure: from 1/4" to 1" PN 140
from 1 1/4" to 2" PN 100
from 2 1/2" to 3" PN 64
- CONNECTIONS: F/F ISO 7/1 Rp - DIN 2999 parallel
- BLOW-OUT PROOF stem from 1/4" to 3"
- ISO 5211 mounting plate
- In the below table the part number and the valve code refer to the standard valve female/male

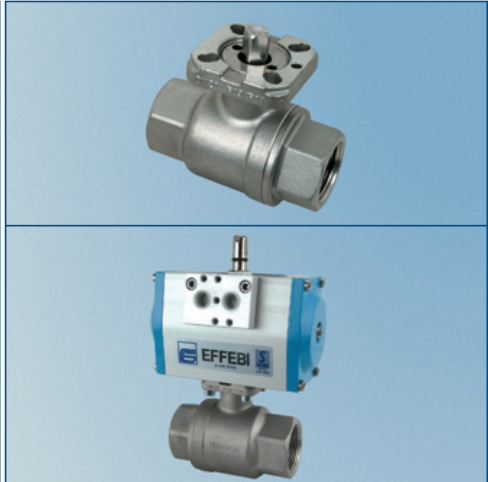

SIZE	PART NUMBER	weight in gr.	A	B	C	D	E	F	H	L	CH	S	T	STEM SQUARE	ISO TOP DRILLING	TORQUE	ACTUATOR code	VALVE code	MOUNTING KIT code
1/4"	D46AA20200	1038	110	53	68	11	19,5	138	40	65	27	7	9	9	F03-F04	4Nm	DNA045AY00	V4608202	KANXOX02
3/8"	D46AA20300	1028	110	53	68	13	19,5	138	40	75	27	7	9	9	F03-F04	4Nm	DNA045AY00	V4608203	KANXOX02
1/2"	D46AA20400	976	110	53	68	16	19,5	138	40	75	27	7	9	9	F03-F04	4Nm	DNA045AY00	V4608204	KANXOX02
3/4"	D46AA20500	1090	110	53	68	20	22	142	44	80	33	9	9	9	F03-F04	6Nm	DNA045AY00	V4608205	KANXOX02
1"	D46AA20600	1510	110	53	68	25	27	150	52	90	41	12	10	11	F04-F05	8Nm	DNA045AW00	V4608206	KANXOX02
1 1/4"	D46AA20700	2365	127	59	74	32	33	162	58	110	50	12	10	11	F04-F05	12Nm	DGA052AX00	V4606207	KANXOX07
1 1/2"	D46AA20800	3781	133	70	88	40	39	186	68	120	58	16	13	14	F05-F07	19Nm	DGA063AX00	V4606208	KANXOX08
2"	D46AA20900	5926	132	83	100	50	48	207	77	140	70	16	13	14	F05-F07	40Nm	DGA075AX00	V4606209	KANXOX09
2 1/2"	D46AA21000	11050	203	100	117	65	60	245	98	185	87	19	13	17	F07-F10	70Nm	DGA092AX00	V4605210	KANXOX10
3"	D46AA21100	16270	222	120	140	80	70	280	110	205	104	19	13	17	F07-F10	90Nm	DNA110AX00	V4605211	KANXOX11

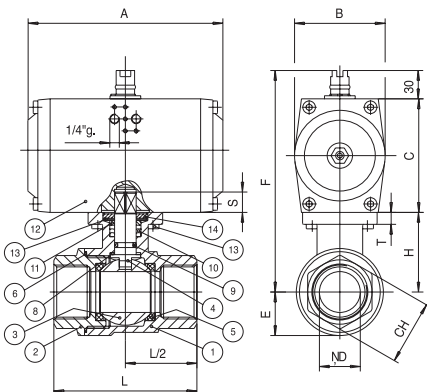

LIST OF VALVE COMPONENTS AND MATERIALS

REF.	PART	QTY	MATERIAL
1	BODY	1	ALSI 316
2	FEMALE END	1	ALSI 316
3	BALL	1	ALSI 316
4	STEM	1	ALSI 316
5	SEAT	2	PTFE
6	SIDE SEALING RING	1	PTFE
8	UPPER SEALING RING	1	PTFE
9	STEM O-RING	1	VITON
10	UPPER SEALING	1	PTFE
11	GLAND WASHER	1	ALSI 304
13	BELLEVILLE WASHERS	2	ALSI 301
14	BLOCKING DISC	1	ALSI 304
58	ACTUATOR SCREW	4	8,8
59	ACTUATOR	1	

For accessories see relevant catalogue sheet

ALBA

2-PIECE BALL VALVE—FULL BORE

MAIN STANDARD FEATURES

- CONSTRUCTION: AISI 316
- CERTIFICATIONS: DVGW for gas up to 2" TUV for TA Luft up to 2"
- DIAMETER: from DN08 - 1/4" to DN 80 - 3"
- PRESSURES: from 100 BAR to 40 BAR
- TEMPERATURE LIMITS: from -20°C to +150°C
- BLOW-OUT PROOF stem
- CONNECTIONS: F/F UNI-ISO 7/1 Rp – DIN 2999 parallel M/F up to 2" (male UNI-ISO 7/1 R taper, female parallel)
- WRAPPING SEATS
- TRIPLE stem-packing with labyrinth effect and automatic adjustment by Belleville washers
- NON-WETTED parts in stainless steel
- OPERATION devices: lever or T-handle
- Tested for vacuum: 1-10⁻³ STD CC/SEC



DVGW GAS APPROVED

STANDARD PART NUMBERS

- | | |
|---|---|
| Art. 2601
female/female w/lever | Art. 2611
female/female w/T-handle up to 1" |
| Art. 2602
male/female w/lever | Art. 2612
male/female w/T-handle up to 1" |

SPECIAL EXECUTIONS

- 15% GLASS-FILLED PTFE. Temperature limits -20°C + 175°C
- PTFE+CARBOGRAPHITE: use up to 195°C, for steam up to 180°C
- FEMALE CONNECTIONS: NPT ANSI B1.20.1
- Stems with antistatic device from 3/4" to 2"
- Degreased version
- 50 mm stem extension up to 2"
- On request the valve is available with ATEX certificate (from 3/4" to 2")
- For further special requests please consult our technical/commercial service

GENERAL APPLICATIONS

Use as an ON-OFF valve for: chemical products, for water and pneumatic installations, gas, water, vacuum. For steam within limited working conditions and with special seals. All parts have to be adequately degreased if the valves have to be used for oxygen.

For special utilizations ascertain the compatibility with process features and the corrosion resistance also by the relevant table.

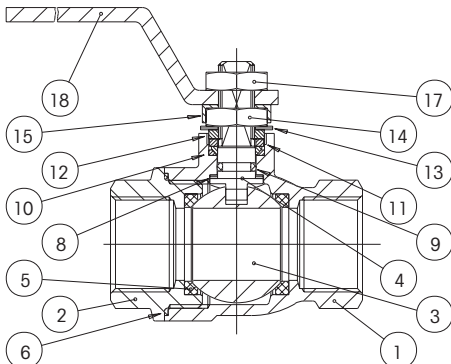

LIST OF COMPONENTS AND MATERIALS

REF.	PART	MATERIAL	DIN MAT.	QTY
1	BODY	AISI 316	1.4408	1
2	FEMALE END	AISI 316	1.4408	1
3	BALL	AISI 316	1.4401	1
4	STEM	AISI 316	1.4401	1
5	SEAT	PTFE	-	2
6	SIDE SEALING RING	PTFE	-	1
8	UPPER SEALING RING	PTFE	-	2
9	STEM O-RING	VITON	-	1
10	UPPER SEALING COUPLE	PTFE	-	1
11	PACKING GLAND	AISI 304	1.4301	1
12	OPERATION STOP	AISI 304	1.4301	1
13	BELLEVILLE WASHERS	AISI 301	1.4310	2
14	STEM RETAINING NUT	AISI 304	1.4301	1
15	FIXING NUT PLATE	AISI 304	1.4301	1
17	LOCKING NUT	AISI 304	1.4301	1
18	LEVER HANDLE	AISI 304	1.4301	1

ALBA

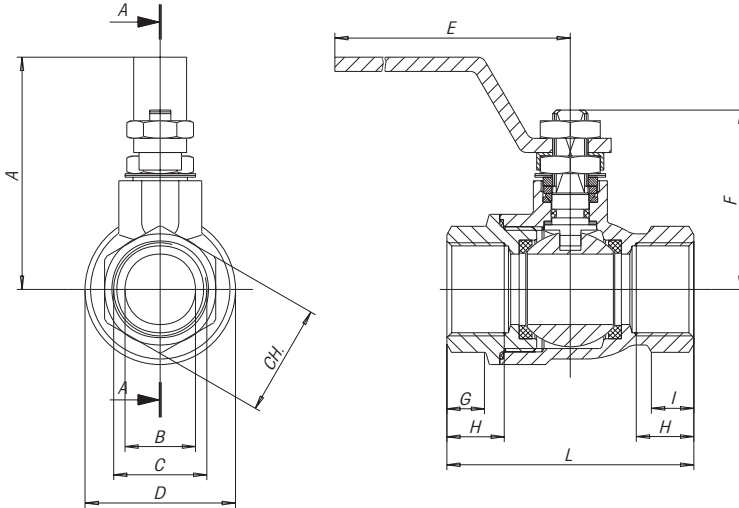
2-PIECE BALL VALVE—FULL BORE

C (inch)	A	B	D	E	F	G	H	I	L	hex. key	oct. key	weight in gr MF	weight in gr FF
1/4"	52	8	29	110	37	8,5	11,4	8	50	21,5	-	230	220
3/8"	52	10	29	110	37	8,5	11,4	8	50	21,5	-	230	205
1/2"	55	15	34	110	42	10	15	9,5	60	26,5	-	315	275
3/4"	66	20	42,5	140	52	11,5	16,3	11,5	70	31,5	-	535	465
1"	70	25	50,5	140	56	14	19,1	13,5	85	40,5	-	805	710
1 1/4"	85	32	63	180	68	15,5	21,4	16	95	-	49,5	1320	1180
1 1/2"	91	40	75,5	180	74	18,5	21,4	16	105	-	54,5	1875	1740
2"	105	50	91	230	87	22,5	25,7	23,5	125	-	69,5	3130	2930
2 1/2"	140	65	116	270	110	27	32,5	30	162	86	-	-	6200
3"	148	80	139	270	125	27	32,5	30	178	101	-	-	9000

BREAKAWAY TORQUES in Nm

PN - bar	DN size									
	10 1/4-3/8"	15 1/2"	20 3/4"	25 1"	32 1 1/4"	40 1 1/2"	50 2"	65 2 1/2"	80 3"	
0	1.6	3.2	3.6	4.6	11.5	19	27.5	65	78	
16	1.8	4.3	4.9	5.9	15	24	38	74	87	
40	2.5	5.1	6	6.9	16.7	28.6	42	84	97	
64	3.2	5.6	6.8	8						
100	3.8	6.5								

The values in Nm may vary as a function of the seals material, temperature and type of medium. For a firm operation of the various types of actuators, in the different working conditions it is necessary to consider a safety factor of 1.5. During operation, with frequent open and close cycles, the operating torque can decrease considerably in comparison with the initial breakaway torque.

Nm

PRESSURE/TEMPERATURE DIAGRAM

At each pressure level corresponds the admissible temperature level.

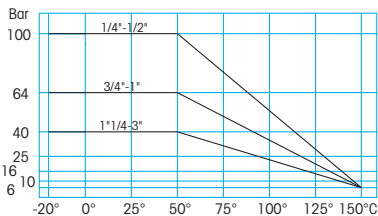
LOSS OF HEAD DIAGRAM/FLOW RATE

The Kv value is the flow rate causing a pressure drop of 1 bar

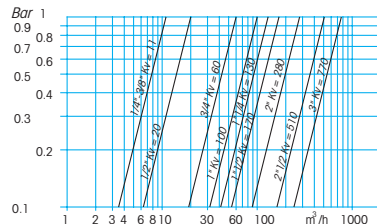

SUNNY

2-PIECE BALL VALVE—FULL BORE

MAIN STANDARD FEATURES

- CONSTRUCTION: AISI 316
- DIAMETER: from DNO8 - 1/4" to DN 50 - 2"
- PRESSURES: from 100 BAR to 40 BAR
- TEMPERATURE LIMITS: from -20°C to +150°C
- BLOW-OUT PROOF stem
- CONNECTIONS: F/F UNI-ISO 7/1 Rp - DIN 2999 parallel
M/F (male UNI-ISO 7/1 R taper, female parallel)
- WRAPPING SEATS
- TRIPLE stem-packing with labyrinth effect and automatic adjustment by Belleville washers
- NON-WETTED parts in stainless steel
- OPERATION devices: lever or T-handle
- Tested for vacuum: 1-10⁻³ STD CC/SEC

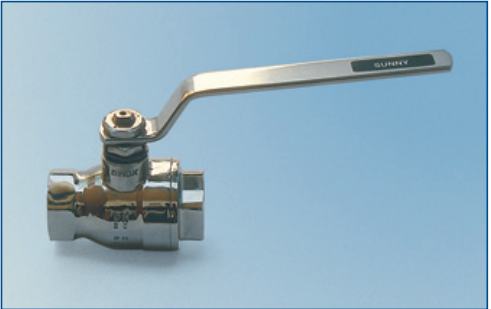

STANDARD PART NUMBERS

Art. 2621 female/female w/lever	Art. 2631 female/female w/T-handle up to 1"
Art. 2622 male/female w/lever	Art. 2632 male/female w/T-handle up to 1"

SPECIAL EXECUTIONS

- 15% GLASS-FILLED PTFE. Temperature limits -20°C + 175°C
- PTFE+CARBOGRAPHITE: use up to 195°C, for steam up to 180°C
- FEMALE CONNECTIONS: NPT ANSI B1.20.1
- Stems with antistatic device from 3/4" to 2"
- Degreased version
- Available also in SUNNY WP version, obtained from SUN WP series
- On request the valve is available with ATEX certificate (from 3/4" to 2")

GENERAL APPLICATIONS

Use as an ON-OFF valve for: chemical, sanitation and food products, for water and pneumatic installations, gas, water, vacuum. For steam within limited working conditions and with special seals. All parts have to be adequately degreased if the valves have to be used for oxygen. For special utilizations ascertain the compatibility with process features and the corrosion resistance also by the relevant table.

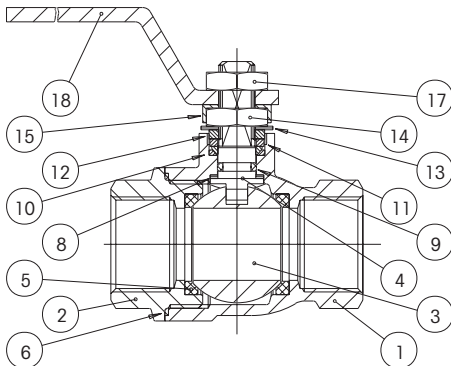

LIST OF COMPONENTS AND MATERIALS

REF.	PART	MATERIAL	DIN MAT.	QTY
1	BODY	AISI 316	1.4408	1
2	FEMALE END	AISI 316	1.4408	1
3	BALL	AISI 316	1.4401	1
4	STEM	AISI 316	1.4401	1
5	SEAT	PTFE	-	2
6	SIDE SEALING RING	PTFE	-	1
8	UPPER SEALING RING	PTFE	-	2
9	STEM O-RING	VITON	-	1
10	UPPER SEALING COUPLE	PTFE	-	1
11	PACKING GLAND	AISI 304	1.4301	1
12	OPERATION STOP	AISI 304	1.4301	1
13	BELLEVILLE WASHERS	AISI 304	1.4301	2
14	STEM RETAINING NUT	AISI 304	1.4301	1
15	FIXING NUT PLATE	AISI 304	1.4301	1
17	LOCKING NUT	AISI 304	1.4301	1
18	LEVER HANDLE	AISI 304	1.4301	1

SUNNY

BALL VALVE—REDUCED BORE

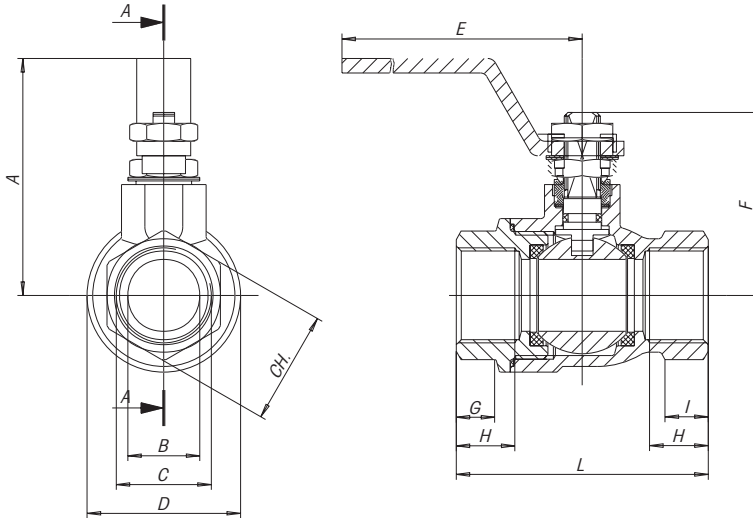

C (inch)	A	B	D	E	F	G	H	I	L	hex. key	oct. key	weight in gr MF	weight in gr FF
1/4"	52	8	29	110	37	8.5	11.4	8	50	21.5	-	230	220
3/8"	52	10	29	110	37	8.5	11.4	8	50	21.5	-	230	205
1/2"	55	15	34	110	42	10	15	9.5	60	26.5	-	315	275
3/4"	66	20	42.5	140	52	11.5	16.3	11.5	70	31.5	-	535	465
1"	70	25	50.5	140	56	14	19.1	13.5	85	40.5	-	805	710
1 1/4"	85	32	63	180	68	15.5	21.4	16	95	-	49.5	1320	1180
1 1/2"	91	40	75.5	180	74	18.5	21.4	16	105	-	54.5	1875	1740
2"	105	50	91	230	87	22.5	25.7	23.5	125	-	69.5	3130	2930

BREAKAWAY TORQUES in Nm

PN - bar	DN size		10		15		20		25		32		40		50	
	1/4-3/8"	1/2"	1/2"	3/4"	1"	1 1/4"	1 1/2"	2"	2 1/2"	3"	3 1/2"	4"	5"	6"	8"	10"
0	1.6	3.2	3.6	4.6	11.5	19	27.5									
16	1.8	4.3	4.9	5.9	15	24	38									
40	2.5	5.1	6	6.9	16.7	28.6	42									
64	3.2	5.6	6.8	8												
100	3.8	6.5														

The values in Nm may vary as a function of the seals material, temperature and type of medium. For a firm operation of the various types of actuators, in the different working conditions it is necessary to consider a safety factor of 1.5. During operation, with frequent open and close cycles, the operating torque can decrease considerably in comparison with the initial breakaway torque.

PRESSURE/TEMPERATURE DIAGRAM

At each pressure level corresponds the admissible temperature level.

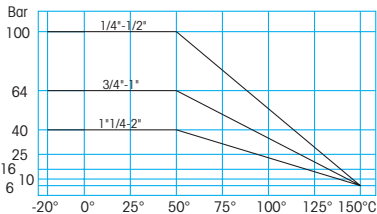

LOSS OF HEAD DIAGRAM/FLOW RATE

The Kv value is the flow rate causing a pressure drop of 1 bar

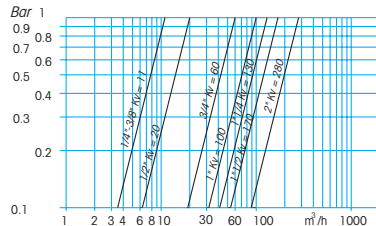

MINIBINOX

BALL VALVE—REDUCED BORE

MAIN STANDARD FEATURES

- CONSTRUCTION: AISI 316
- DIAMETER: from DNO6 - 1/8" to DN 15 - 1/2"
- PRESSURES: 25 bar max.
- TEMPERATURE LIMITS: from -20°C to +150°C
- BLOW-OUT PROOF stem
- CONNECTIONS: F/F UNI-ISO 228 (gas parallel)
M/F UNI-ISO 228 (gas parallel)
- NON-WETTED parts in stainless steel
- OPERATION devices: little lever handle
- FINISH: glazing



STANDARD PART NUMBERS

Art. 2641

female/female

Art. 2642

male/female

SPECIAL EXECUTIONS

- BODY finish: polishing
- For further special requests please consult our technical/commercial service

GENERAL APPLICATIONS

Use as an ON-OFF valve for: in sight segments in industrial installations, heating, ventilation, air conditioning, compressed air, as tank discharger and especially in instrumentation.

For special utilisations ascertain the compatibility with process features and the corrosion resistance also by the relevant table.

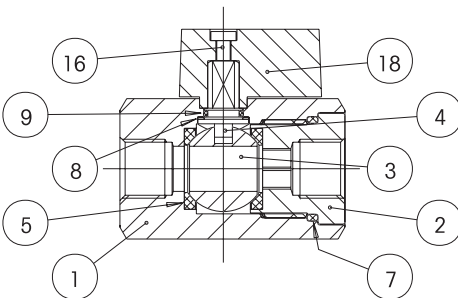

LIST OF COMPONENTS AND MATERIALS

REF.	PART	MATERIAL	DIN MAT.	QTY
1	BODY	AISI 316	1,4408	1
2	FEMALE END	AISI 316	1,4408	1
3	BALL	AISI 316	1,4401	1
4	STEM	AISI 316	1,4401	1
5	SEAT	PTFE	-	2
7	END O-RING	VITON	-	1
8	UPPER SEALING RING	PTFE	-	2
9	STEM O-RING	VITON	-	1
16	LOCKING SCREW	AISI 304	1,4301	-
18	LITTLE LEVER HANDLE	NYLON	-	1

MINIBINOX

BALL VALVE—REDUCED BORE

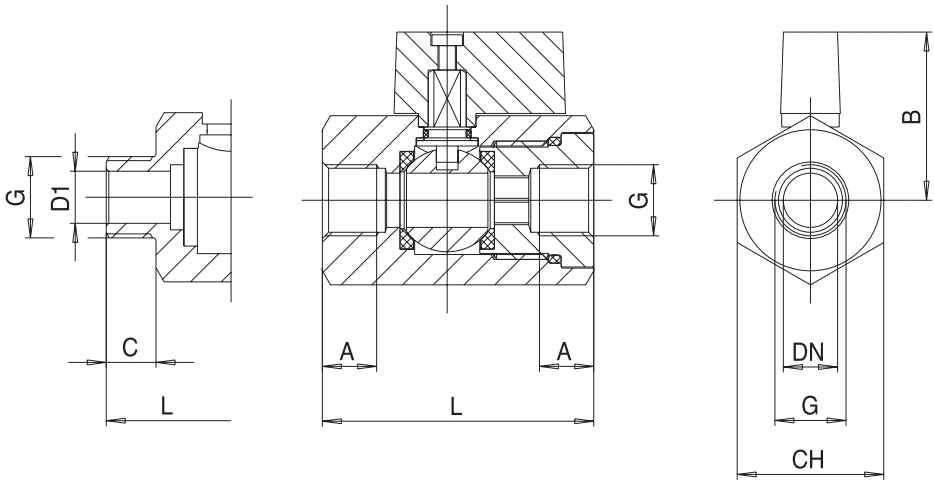

G (inch)	DN	A	B	C	L	D1 (MH)	CH	weight in gr Fr	weight in gr Fr
1/8"	6	10	30	9	50	5.5	27	210	175
1/4"	8	10	30	11	50	8	27	200	170
3/8"	10	10	30	11	50	10	27	190	165
1/2"	10	10	30	11	50	10	27	175	160

PRESSURE/TEMPERATURE DIAGRAM

At each pressure level corresponds the admissible temperature level.

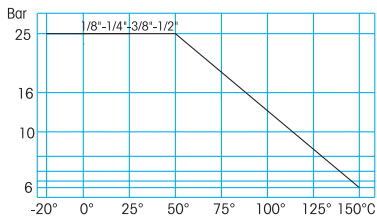

LOSS OF HEAD DIAGRAM/FLOW RATE

The Kv value is the flow rate causing a pressure drop of 1 bar

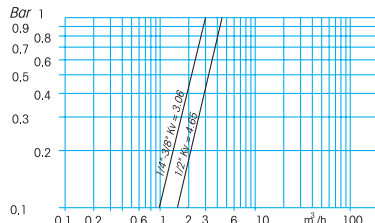

MONOBLOCK AISI 316

2-PIECE BALL VALVE—FULL BORE

MAIN STANDARD FEATURES

- CONSTRUCTION: AISI 316
- General prescriptions: BS 5351
- Valves certified FIRE SAFE to: BS 6755 - API 6 FA - API 607
- DIAMETER: from DN 8-1/4" to DN 100-4"
- PRESSURES:
 - series 800 PN64 1/4" + 4" PTFE
 - series 1500 PN100 1"1/4 + 2" PTFE
 - series 3000 PN64 1/4" + 4" CARBOGRAPHITE
 - series 3000 PN210 1/4" + 2" DELRIN
- TEMPERATURE LIMITS
 - 20°C+ 180°C with PTFE
 - + 210°C with PTFE+CARBOGRAPHITE
 - + 80°C with DELRIN
- BLOW-OUT PROOF stem with antistatic device
- CONNECTIONS: F/F UNI-ISO 7/1 Rp - DIN 2999 parallel
 - SWB ANSI B 16.11 socket weld
 - BW ANSI B 16.25 butt weld sch 40
- OPERATION device: lever handle



STANDARD PART NUMBERS

Class 800-1500	Class 3000	Connection
Art. 2660	Art. 2655	female/female GAS
Art. 2662	Art. 2656	socket weld SW
Art. 2663	Art. 2657	butt weld BW

SPECIAL EXECUTIONS

- Integral weld-on extension nipples SW or BW up to 2" (see separate data sheet)
- FEMALE CONNECTIONS: NPT ANSI B1.20.1
- Degreased version
- Locking device
- On request the valve is available with ATEX certificate
- For further special requests please consult our technical/commercial service

GENERAL APPLICATIONS

Use as an ON-OFF valve for: industrial plants at high pressure and temperature, chemical and petrochemical installations, water and pneumatic installations, for steam up to 195°C. All parts have to be adequately degreased if the valves have to be used for oxygen.

For special utilizations ascertain the compatibility with process features and the corrosion resistance also by the relevant table.

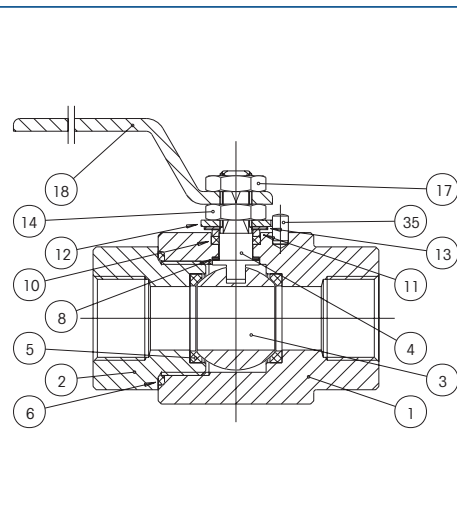

LIST OF COMPONENTS AND MATERIALS

REF.	PART	MATERIAL	DIN MAT.	QTY
1	BODY	AISI 316	1.4401	1
2	FEMALE END	AISI 316	1.4401	1
3	BALL	AISI 316	1.4401	1
4	STEM	AISI 316	1.4401	1
5	SEAT	PTFE		2
6	SIDE SEALING RING	PTFE		1
8	UPPER RING	PTFE		2
10	UPPER SEAL	PTFE		1
11	PACKING GLAND	S.S.		1
12	OPERATION STOP	S.S.		1
13	BELLEVILLE WASHERS	S.S.		2
14	STEM RETAINING NUT	A2		1
17	LOCKING NUT	A2		1
18	LEVER HANDLE	S.S.		1
35	PIN	S.S.		1

MONOBLOCK AISI 316

2-PIECE BALL VALVE—FULL BORE

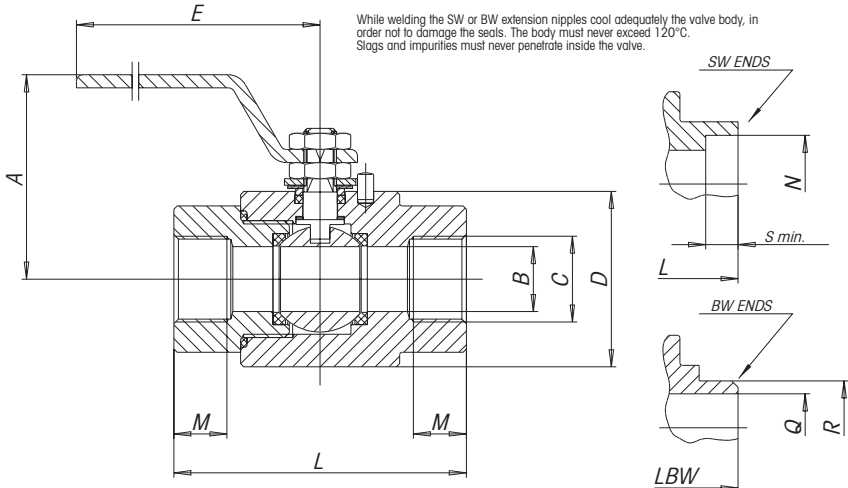

C (Inch)	A	B	D	E	L	LBW	M	N	S	R	Q	weight in gr. GAS	weight in gr. SW	weight in gr. BW
1/4"	72	10	42	148	67	95	11	14.3	9.53	13.7	9.3	610	610	630
3/8"	72	10	42	148	67	95	11.4	17.8	9.53	17.5	12.5	615	615	650
1/2"	75	15	50	148	75	105	15	22	9.53	21.3	16	930	930	1050
3/4"	85	20	60	180	90	125	16.3	27.3	12.7	26.7	21	1550	1550	1600
1"	95	25	68	180	105	140	19.1	34	12.7	33.4	27	2265	2265	2350
1 1/4"	100	30	81	240	120	160	21.4	42.8	12.7	43	35	3300	3300	3400
2 1/2"	105	38	94	240	135	180	21.4	48.9	12.7	48.3	41	4850	4850	5400
2"	115	48	105	280	155	220	25.7	61.4	15.88	60.3	53	6490	6490	6800
3"	145	73	150	380	205	280	33.3	90	15.88	88.9	78	17000	17000	17500
4"	200	94	185	470	230	330	39.3	115.7	19.1	114.3	103	24000	24000	24500
2 1/2"	130	65	130	380	190	250	30.2	73.81	15.22	73.1	65	13000	13000	13400

BREAKAWAY TORQUES in Nm

DN size	10	15	20	25	32	40	50	80	100
PN - bar	1/4"-3/8"	1/2"	3/4"	1"	1 1/4"	1 1/2"	2"	3"	4"
0	10	12	16	21	54	65	86	183	270
64	15	18.6	23	27	80	83.6	126.6	240	350
105	17	22.6	25.2	29.6	88	92.9	131	260	389
160	19.5	24.7	26.6	31.3					
210	23.4	27.6	30	34.8					

The values in Nm may vary as a function of the seals material, temperature and type of medium. For a firm operation of the various types of actuators, in the different working conditions it is necessary to consider a safety factor of 1.5. During operation, with frequent open and close cycles, the operating torque can decrease considerably in comparison with the initial breakaway torque.

PRESSURE/TEMPERATURE DIAGRAM

At each pressure level corresponds the admissible temperature level.

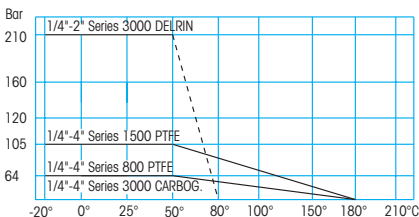

LOSS OF HEAD DIAGRAM/FLOW RATE

The Kv value is the flow rate causing a pressure drop of 1 bar

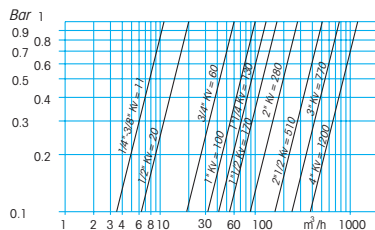

MONOBLOCK A 105

2-PIECE BALL VALVE—FULL BORE

MAIN STANDARD FEATURES

- CONSTRUCTION: ASTM A 105
- General prescriptions: BS 5351
- Valves certified FIRE SAFE to: BS 6755 - API 6 FA - API 607
- DIAMETER: from DN 8-1/4" to DN 100-4"
- PRESSURES:
 - series 800 PN 64 1/4" + 4" PTFE
 - series 1500 PN 100 1 1/4" + 2" PTFE
 - series 3000 PN 64 1/4" + 4" CARBOGRAPHITE
 - series 3000 PN 210 1/4" + 2" DELRIN
- TEMPERATURE LIMITS
 - 20°C + 180°C with PTFE
 - + 210°C with PTFE+CARBOGRAPHITE
 - + 80°C with DELRIN
- BLOW-OUT PROOF stem with antistatic device
- CONNECTIONS: F/F UNI-ISO 7/1 Rp - DIN 2999 parallel
 - SWB ANSI B 16.11 socket weld
 - BW ANSI B 16.25 butt weld sch 40
- OPERATION device: lever handle



STANDARD PART NUMBERS

Class 800-1500	Class 3000	Connection
Art. 2651	Art. 2685	female/female GAS
Art. 2652	Art. 2686	socket weld SW
Art. 2653	Art. 2687	butt weld BW

SPECIAL EXECUTIONS

- Integral weld-on extension nipple SW or BW up to 2" (see separate data sheet)
- FEMALE CONNECTIONS: NPT ANSI B1.20.1
- Locking device
- On request the valve is available with ATEX certificate
- For further special requests please consult our technical/commercial service

GENERAL APPLICATIONS

Use as an ON-OFF valve for: industrial plants at high pressure and temperature, refineries, water and pneumatic installations, for steam up to 195°C.

For special utilizations ascertain the compatibility with process features and the corrosion resistance also by the relevant table.

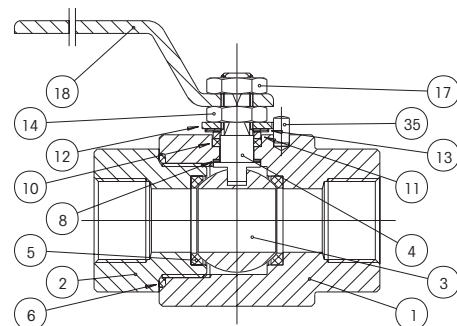

LIST OF COMPONENTS AND MATERIALS

REF.	PART	MATERIAL	DIN MAT.	QTY
1	BODY	ASTM A105		1
2	FEMALE END	ASTM A105		1
3	BALL	AISI 304	1.4301	1
4	STEM	AISI 304/F6		1
5	SEAT	PTFE		2
6	SIDE SEALING RING	PTFE		1
8	UPPER RING	PTFE		2
10	UPPER SEAL	PTFE		1
11	PACKING GLAND	S.S.		1
12	OPERATION STOP	S.S.		1
13	BELLEVILLE WASHERS	50CrV4		2
14	STEM RETAINING NUT	S.S.		1
17	LOCKING NUT	S.S.		1
18	LEVER HANDLE	S.S.		1
35	PIN	S.S.		1

MONOBLOCK A 105

2-PIECE BALL VALVE—FULL BORE

While welding the SW or BW extension nipples cool adequately the valve body, in order not to damage the seals. The body must never exceed 120°C. Slugs and impurities must never penetrate inside the valve.

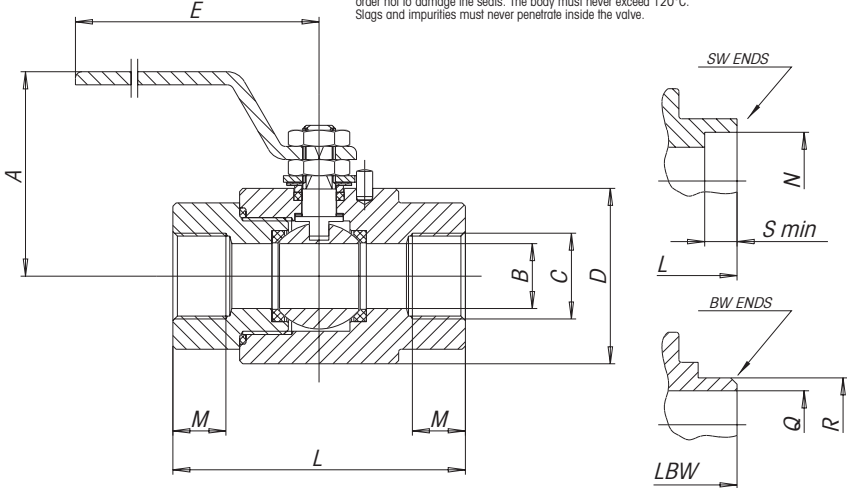

C (Inch)	A	B	D	E	L	LBW	M	N	S	R	Q	weight in gr. GAS	weight in gr. SW	weight in gr. BW
1/4"	72	10	42	148	67	95	11	14.3	9.53	13.7	9.3	610	610	630
3/8"	72	10	42	148	67	95	11.4	17.8	9.53	17.5	12.5	615	615	650
1/2"	75	15	50	148	75	105	15	22	9.53	21.3	16	930	930	1050
3/4"	85	20	60	180	90	125	16.3	27.3	12.7	26.7	21	1550	1550	1600
1"	95	25	68	180	105	140	19.1	34	12.7	33.4	27	2265	2265	2350
1 1/4"	100	30	81	240	120	160	21.4	42.8	12.7	43	35	3300	3300	3400
2 1/2"	105	38	94	240	135	180	21.4	48.9	12.7	48.3	41	4850	4850	5400
2"	115	48	105	280	155	220	25.7	61.4	15.88	60.3	53	6490	6490	6800
3"	145	73	150	380	205	280	33.3	90	15.88	88.9	78	17000	17000	17500
4"	200	94	185	470	230	330	39.3	115.7	19.1	114.3	103	24000	24000	24500

BREAKAWAY TORQUES in Nm

PN - bar	DN size									
	10 1/4"-3/8"	15 1/2"	20 3/4"	25 1"	32 1 1/4"	40 1 1/2"	50 2"	80 3"	100 4"	
0	10	12	16	21	54	65	86	183	270	
64	15	18.6	23.8	27	80	83.6	126.6	240	350	
105	17	22.6	25.2	29.6	88	92.9	131	260	389	
160	19.5	24.7	26.6	31.3						
210	23.4	27.6	30	34.8						

The values in Nm may vary as a function of the seals material, temperature and type of medium. For a firm operation of the various types of actuators, in the different working conditions it is necessary to consider a safety factor of 1.5. During operation, with frequent open and close cycles, the operating torque can decrease considerably in comparison with the initial breakaway torque.

PRESSURE/TEMPERATURE DIAGRAM

At each pressure level corresponds the admissible temperature level.

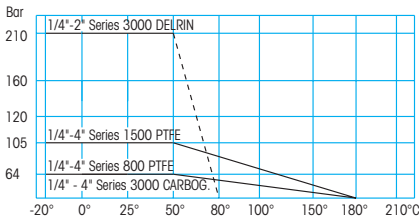

LOSS OF HEAD DIAGRAM/FLOW RATE

The Kv value is the flow rate causing a pressure drop of 1 bar

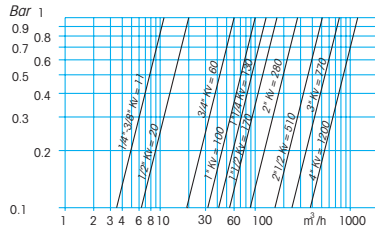

MONOBLOCK TI

2-PIECE BALL VALVE—FULL BORE

MAIN STANDARD FEATURES

- CONSTRUCTION: AISI 316 and ASTM A 105
- General prescriptions: BS 5351
- DIAMETER: from DN 8-1/4" to DN 50-2"
- PRESSURES: series 800 - 1500 (64-105 bar)
- TEMPERATURE LIMITS
-20°C + 210°C with PTFE+CARBOGRAPHITE
- BLOW-OUT PROOF stem with antistatic device
- CONNECTIONS SWB ANSI B 16.11 socket weld
BW ANSI B 16.25 butt weld sch 40
- OPERATION device: lever handle

FIRE SAFE



STANDARD PART NUMBERS

Art. 2679	socket weld	SW AISI 316
Art. 2680	butt weld	BW AISI 316
Art. 2682	socket weld	SW A 105
Art. 2683	butt weld	BW A 105

SPECIAL EXECUTIONS

- PTFE seals with temperature limits from -20°C to +180°C
- BW sch 80 for series 1500 lbs
- On request the valve is available with ATEX certificate
- For further special requests please consult our technical/commercial service

GENERAL APPLICATIONS

Use as an ON-OFF valve for: installations with the features described for MONOBLOCK ball valves in AISI 316 and ASTM A105. For special utilizations ascertain the compatibility with process features and the corrosion resistance also by the relevant table.

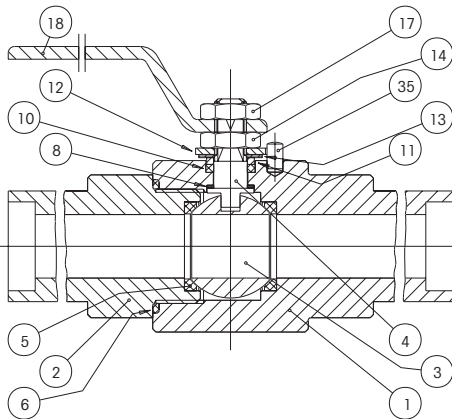

LIST OF COMPONENTS AND MATERIALS

REF.	PART	MATERIAL	DIN MAT.	QTY
1	BODY	AISI 316	1.4401	1
2	EXTENSION NIPPLE	AISI 316	1.4401	1
3	BALL	AISI 316	1.4401	1
4	STEM	AISI 316	1.4401	1
5	SEAT	#		2
6	SIDE SEALING RING	#		1
8	UPPER RING	#		2
10	UPPER SEAL	#		1
11	PACKING GLAND	S.S.		1
12	OPERATION STOP	S.S.		1
13	BELLEVILLE WASHERS	S.S.		2
14	STEM RETAINING NUT	A2		1
17	LOCKING NUT	A2		1
18	LEVER HANDLE	S.S.		1
35	PIN	S.S.		1

: PTFE+CARBOGRAPHITE

MONOBLOCK TI

2-PIECE BALL VALVE—FULL BORE

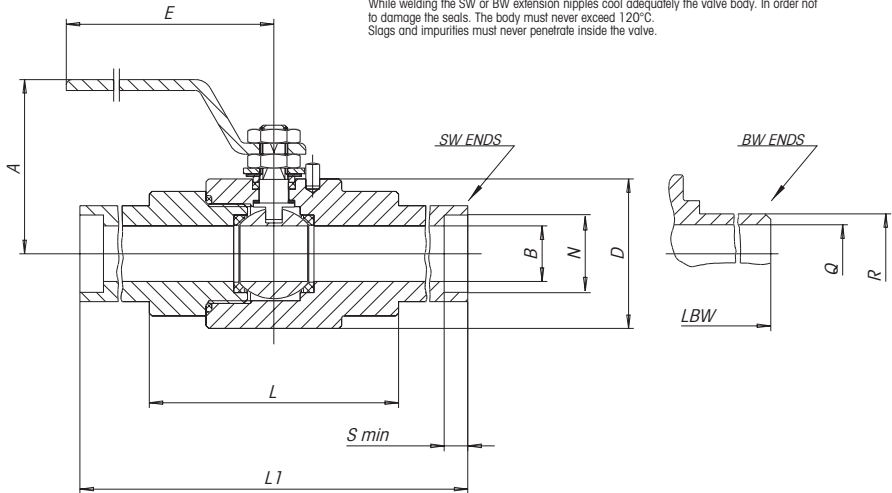

MISURA	A	B	D	E	L	L1	N	S	R	Q	peso in gr. SW	peso in gr. BW
1/4"	72	10	42	148	67	267	14.3	9.53	13.7	9.3	900	750
3/8"	72	10	42	148	67	267	17.8	9.53	17.5	12.5	1050	800
1/2"	75	15	50	148	75	275	22	9.53	21.3	16	1600	1200
3/4"	85	20	60	180	90	290	27.3	12.7	26.7	21	2400	1900
1"	95	25	68	180	105	305	34	12.7	33.4	27	3700	2800
1 1/4"	100	30	81	240	120	320	42.8	12.7	43	35	5500	4000
1 1/2"	105	38	94	240	135	335	48.9	12.7	48.3	41	7200	5700
2"	115	48	105	280	155	355	61.4	15.88	60.3	53	9900	7600

BREAKAWAY TORQUES in Nm

PN - bar	DN size							
	10	15	20	25	32	40	50	
0	1/4"-3/8"	1/2"	3/4"	1"	1 1/4"	1 1/2"	2"	
64	10	12	16	21	54	65	86	
105	15	18.6	23	27	80	83.6	126.6	
	17	22.6	25.2	29.6	88	92.9	131	

Nm

The values in Nm may vary as a function of the seals material, temperature and type of medium. For a firm operation of the various types of actuators, in the different working conditions it is necessary to consider a safety factor of 1.5. During operation, with frequent open and close cycles, the operating torque can decrease considerably in comparison with the initial breakaway torque.

PRESSURE/TEMPERATURE DIAGRAM

At each pressure level corresponds the admissible temperature level.

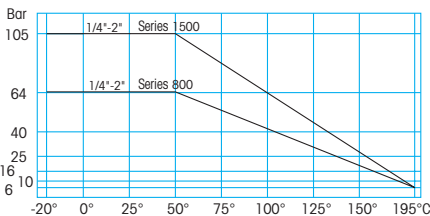

LOSS OF HEAD DIAGRAM/FLOW RATE

The Kv value is the flow rate causing a pressure drop of 1 bar

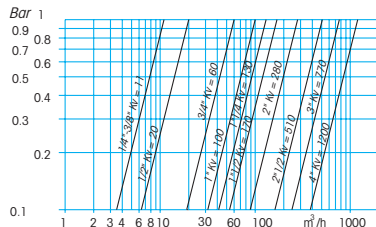

TITAN

3-PIECE BALL VALVE—FULL BORE

MAIN STANDARD FEATURES

- CONSTRUCTION: ASTM A351 CF8M (AISI 316)
- DIAMETER: from DNO8 - 1/4" to DN 50 - 2"
- PRESSURES: PN 140 from 1/4" to 1"
PN 100 from 1"1/4 to 2"
- TEMPERATURE LIMITS: from -20°C to +150°C
- BLOW-OUT PROOF stem with antistatic device
- CONNECTIONS: F/F UNI-ISO 7/1 Rp – DIN 2999 parallel Gas
SW ANSI B 16.11 socket weld
BW ANSI B 16.25 butt weld sch 40
F/F NPT ANSI B 1.20.1
- WRAPPING seats
- Stem-packing with labyrinth effect
- Non wetted parts in stainless steel
- OPERATION device: lever handle
- Iso 5211 mounting plate
- Locking device



STANDARD PART NUMBERS

- Art. 2805** female/female w/lever GAS and NPT
Art. 2810 SW ANSI B 16.11 w/lever
Art. 2815 BW ANSI B 16.25 w/lever

SPECIAL EXECUTIONS

- 2" 1/2 - 3" SW and GAS with reduced bore
- PTFE + CARBOGRAPHITE up to 180°C
- Degreased version
- On request the valve is available with ATEX certificate
- For further special requests please consult our technical/commercial service

GENERAL APPLICATIONS

Use as an ON-OFF valve for: chemical, water and pneumatic installations, for plants with high interchangeability of components and for steam up to 10 bar. The valves are designed and manufactured in order to allow inspections and maintenances on line by extracting only the body. For special utilizations ascertain the compatibility with process features and the corrosion resistance also by the relevant table.

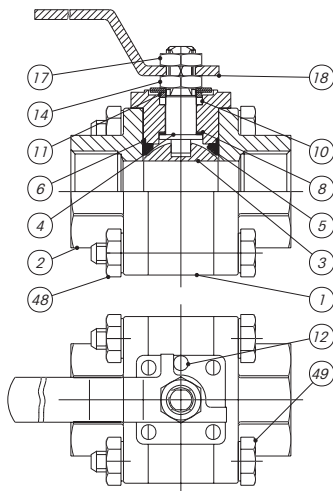

LIST OF COMPONENTS AND MATERIALS

REF.	PART	MATERIAL	DIN MAT.	QTY
1	BODY	A351-CF8M	1.4401	1
2	FEMALE END	A351-CF8M	1.4401	2
3	BALL	AISI 316	1.4401	1
4	STEM	AISI 316	1.4401	1
5	SEAT	PTFE		2
6	SIDE SEALING RING	PTFE		2
8	UPPER RING	PTFE		1
10	UPPER SEAL	PTFE		1
11	PACKING GLAND	AISI 316	1.4401	1
12	OPERATION STOP	AISI 304	1.4301	1
14	STEM RETAINING NUT	AISI 304	1.4301	1
17	LOCKING NUT	AISI 304	1.4301	1
18	LEVER HANDLE	AISI 304	1.4301	1
48	BOLT	S.S.		4
49	NUT	S.S.		4

TITAN

3-PIECE BALL VALVE—FULL BORE

While welding the SW or BW extension nipples cool adequately the valve body. In order not to damage the seals. The body must never exceed 120°C. Slags and impurities must never penetrate inside the valve.

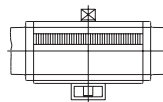
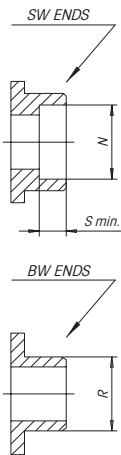
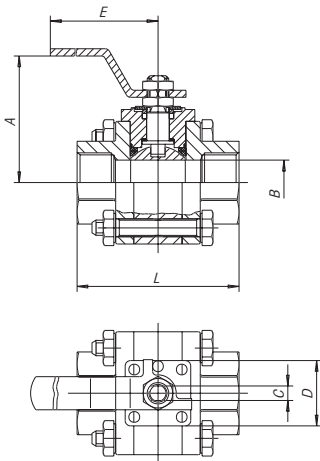

By removing the lever handle, the TITAN valve can be assembled directly with an actuator by means of a bracket, the stem adapter (kit supplied on request) and by eliminating the operation stop (part. 12).

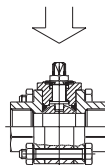

C (Inch)	A	B	C	D	E	L	N	R	S	ISO 5211	weight in gr. FF
1/4"	49	10.9	4,7	36	95.5	61	17.8	18	9.7	F03	630
3/8"	49	12.7	4,7	36	95.5	61	17.8	18	9.7	F03	630
1/2"	63	16	5	36	120.5	71	22	22.5	12.7	F03	860
3/4"	63	19.6	5	36	120.5	81.5	27.3	28	12.7	F03	1450
1"	68	25	8	42	162.5	91.5	34	34.5	12.7	F04	2810
1 1/4"	80.5	32	8	42	162.5	114.5	42.8	43.5	12.7	F04	3810
1 1/2"	85	38.1	9,5	50	203	122	48.9	49.5	12.7	F05	5080
2"	97.5	50.8	9,5	50	203	142.7	61.4	61.5	15.8	F05	6580

BREAKAWAY TORQUES in Nm

DN size	10	15	20	25	32	40	50
	1/4"	3/8"	1/2"	3/4"	1"	1 1/4"	1 1/2"
0	10	10	12	16	20	38	55
64	15	15	20	24	27	52	98
105	18	18	23	25	29	80	125
140	19	19	24.5	26	31		

Nm

The values in Nm may vary as a function of the seals material, temperature and type of medium. For a firm operation of the various types of actuators, in the different working conditions it is necessary to consider a safety factor of 1.5. During operation, with frequent open and close cycles, the operating torque can decrease considerably in comparison with the initial breakaway torque.

PRESSURE/TEMPERATURE DIAGRAM

At each pressure level corresponds the admissible temperature level.

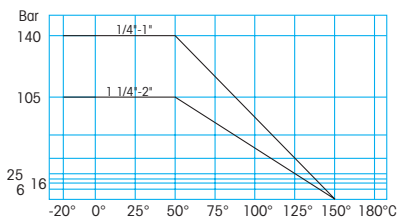

LOSS OF HEAD DIAGRAM/FLOW RATE

The Kv value is the flow rate causing a pressure drop of 1 bar

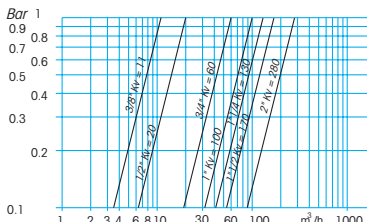

TITAN

3-PIECE BALL VALVE - FULL BORE WITH DOUBLE ACTING PNEUMATIC ACTUATOR

ACTUATOR FEATURES

- Rotation angle: 90°
- Standard version for temperature between -20°C and + 90°C
- Supply maximum pressure: 10 bar (8bar for DNA045)
- Nominal pressure: 5,62 bar
- Supply medium: dry filtered compressed air, not necessarily lubricated
- Lubrication: in such a case use a non-detergent or NBR compatible oil

STANDARD VALVE FEATURES

- Working temperature: from -20°C to +150°C
- Working pressure: PN140 from 1/4" to 1", PN100 from 1 1/4 to 2"
- CONNECTIONS: F/F UNI-ISO 7/1 Rp - DIN 2999 parallel GAS
F/F NPT
SW ANSI B16.11 socket weld
BW ANSI B16.25 butt weld sch.40
- BLOW-OUT PROOF stem with antistatic device
- For general applications and special versions see technical table of manual valve
- In the below table the part number and the valve code refer to the standard valve version F/F UNI ISO 7/1 Rp - DIN 2999 parallel GAS



SIZE	PART NUMBER	weight in gr.	A	B	C	E	F	CI opt.	L	M	N	ACTUATOR code	VALVE code	MOUNTING KIT code
1/4"	D61AA20200	1240	110	53	68	21	153	20.5	61	42	10.9	DNA045AZ00	3805X202	K1GA0002
3/8"	D61AA20300	1240	110	53	68	21	153	23.5	61	42	12.7	DNA045AZ00	3805X203	K1GA0002
1/2"	D61AA20400	1825	127	59	74	26	173.5	29.5	71	52	16	DGA052AX00	3805X204	K1GA0304
3/4"	D61AA20500	2475	127	59	74	30	178.5	35	81.5	59.5	19.6	DGA052AX00	3805X205	K1GA0305
1"	D61AA20600	4575	133	70	88	36	198.5	43	91.5	72	25	DGA063AX00	3805X206	K1GA0406
1 1/4"	D61AA20700	5675	133	70	88	40	202	53	114.5	79.5	32	DGA063AX00	3805X207	K1GA0407
1 1/2"	D61AA20800	7730	132	83	100	45	227	61	122	90	38.1	DGA075AX00	3805X208	K1GA0308
2"	D61AA20900	9985	182	91	108	50.5	243.5	76	142.7	101	50.8	DGA083AX00	3805X209	K1GA0308

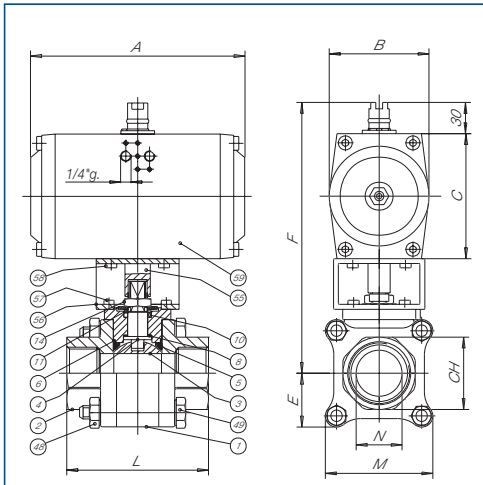

LIST OF VALVE COMPONENTS AND MATERIALS

REF.	PART	QTY	MATERIAL
1	BODY	1	A351-CF8M
2	FEMALE END	2	A351-CF8M
3	BALL	1	AISI 316
4	STEM	1	AISI 316
5	SEAT	2	PTFE
6	SIDE SEALING RING	2	PTFE
8	UPPER RING	1	PTFE
10	UPPER SEAL	1	PTFE
11	PACKING GLAND	1	AISI 316
14	STEM RETAINING NUT	1	AISI 304
48	BOLT	4	S.S.
49	NUT	4	S.S.
55	ACTUATOR SHAFT	1	C.S.
56	BRACKET	1	C.S.
57	BRACKET/VALVE SCREW	4	8.8
58	BRACKET/ACTUATOR SCREW	4	8.8
59	ACTUATOR	1	

For accessories see relevant catalogue sheet

TITAN

3-PIECE BALL VALVE - FULL BORE WITH SPRING RETURN PNEUMATIC ACTUATOR

ACTUATOR FEATURES

- Rotation angle: 90°
- Standard version for temperature between -20°C and + 90°C
- Supply maximum pressure: 10 bar
- Nominal pressure: 5,62 bar
- Supply medium: dry filtered compressed air, not necessarily lubricated
- Lubrication: in such a case use a non-detergent or NBR compatible oil

STANDARD VALVE FEATURES

- Working temperature: from -20°C to +150°C
- Working pressure: PN140 from 1/4" to 1", PN100 from 1 1/4 to 2"
- CONNECTIONS: F/F UNI-ISO 7/1 Rp - DIN 2999 parallel GAS
F/F NPT
SW ANSI B16.11 socket weld
BW ANSI B16.25 butt weld sch.40
- BLOW-OUT PROOF stem with antistatic device
- For general applications and special versions see technical table of manual valve
- In the below table the part number and the valve code refer to the standard valve version F/F UNI ISO 7/1 Rp - DIN 2999 parallel GAS

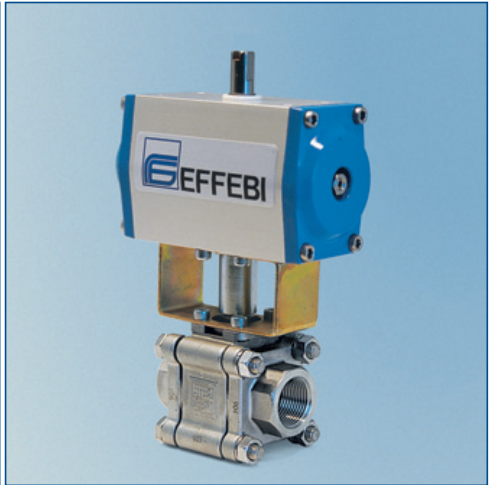

SIZE	PART NUMBER	weight in gr.	A	B	C	E	F	CI odt.	L	M	N	ACTUATOR code	VALVE code	MOUNTING KIT code
1/4"	S61AA20200	2320	133	70	88	21	183	20.5	61	42	10.9	SGA0634X00	3805X202	K1GA0102
3/8"	S61AA20300	2320	133	70	88	21	183	23.5	61	42	12.7	SGA0634X00	3805X203	K1GA0102
1/2"	S61AA20400	3345	132	83	100	26	199.5	29.5	71	52	16	SGA0754X00	3805X204	K1GA0404
3/4"	S61AA20500	3995	132	83	100	30	204.5	35	81.5	59.5	19.6	SGA0754X00	3805X205	K1GA0405
1"	S61AA20600	6135	182	91	108	36	218.5	43	91.5	72	25	SGA0834X00	3805X206	K1GA0506
1 1/4"	S61AA20700	7235	182	91	108	40	222	53	114.5	79.5	32	SGA0834X00	3805X207	K1GA0507
1 1/2"	S61AA20800	11600	222	120	140	45	267	61	122	90	38.1	SNA1104X00	3805X208	K1GA0408
2"	S61AA20900	13250	222	120	140	50.5	275.5	76	142.7	101	50.8	SNA1104X00	3805X209	K1GA0408

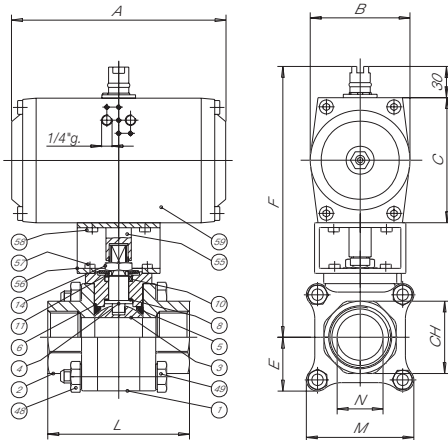

LIST OF VALVE COMPONENTS AND MATERIALS

REF.	PART	QTY	MATERIAL
1	BODY	1	A351-CF8M
2	FEMALE END	2	A351-CF8M
3	BALL	1	AISI 316
4	STEM	1	AISI 316
5	SEAT	2	PTFE
6	SIDE SEALING RING	2	PTFE
8	UPPER RING	1	PTFE
10	UPPER SEAL	1	PTFE
11	PACKING GLAND	1	AISI 316
14	STEM RETAINING NUT	1	AISI 304
48	BOLT	4	S.S.
49	NUT	4	S.S.
55	ACTUATOR SHAFT	1	C.S.
56	BRACKET	1	C.S.
57	BRACKET/VALVE SCREW	4	8.8
58	BRACKET/ACTUATOR SCREW	4	8.8
59	ACTUATOR	1	

For accessories see relevant catalogue sheet

ARGOS

3-PIECE BALL VALVE—FULL BORE

MAIN STANDARD FEATURES

- CONSTRUCTION: ASTM A105 (A216 WCB)
- DIAMETER: from DNO8 - 1/4" to DN 50 - 2"
- PRESSURES: PN 140 from 1/4" to 1"
PN 100 from 1"1/4 to 2"
- TEMPERATURE LIMITS: from -20°C to +150°C
- BLOW-OUT PROOF stem with antistatic device
- CONNECTIONS: F/F UNI-ISO 7/1 Rp – DIN 2999 parallel Gas
SW ANSI B 16.11 socket weld
BW ANSI B 16.25 butt weld sch 40
F/F NPT ANSI B1.20.1
- WRAPPING seats
- Stem-packing with labyrinth effect
- OPERATION device: lever handle
- ISO 5211 mounting plate
- NON-WETTED parts in stainless steel
- Preset for lever locking



STANDARD PART NUMBERS

- Art. 2806** female/female Gas
Art. 2812 SW ANSI B 16.11
Art. 2816 BW ANSI B 16.25

SPECIAL EXECUTIONS

- PTFE + CARBOGRAPHITE suitable up to 180°C
- On request the valve is available with ATEX certificate
- For further special requests please consult our technical/commercial service

GENERAL APPLICATIONS

Use as an ON-OFF valve for: chemical, water and pneumatic installations, for plants with high interchangeability of components and for steam up to 10 bar. The valves are designed and manufactured in order to allow inspections and maintenances on line by extracting only the body. For special utilizations ascertain the compatibility with process features and the corrosion resistance also by the relevant table.

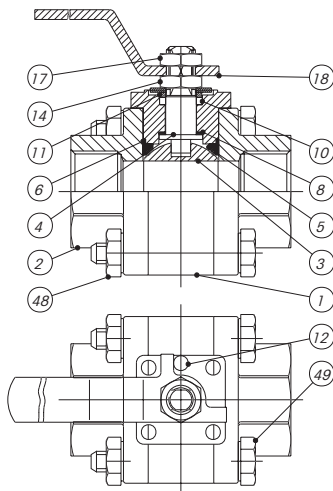

LIST OF COMPONENTS AND MATERIALS

REF.	PART	MATERIAL	DIN MAT.	QTY
1	BODY	A216-WCB		1
2	FEMALE END	A216-WCB		2
3	BALL	AISI 304	1.4301	1
4	STEM	AISI 304	1.4301	1
5	SEAT	PTFE		2
6	SIDE SEALING RING	PTFE		2
8	UPPER RING	PTFE		1
10	UPPER SEAL	PTFE		1
11	PACKING GLAND	AISI 304	1.4401	1
12	OPERATION STOP	AISI 304	1.4301	1
14	STEM RETAINING NUT	AISI 304	1.4301	1
17	LOCKING NUT	AISI 304	1.4301	1
18	LEVER HANDLE	AISI 304	1.4301	1
48	BOLT	S.S.		4
49	NUT	S.S.		4

ARGOS

3-PIECE BALL VALVE—FULL BORE

While welding the SW or BW extension nipples cool adequately the valve body. In order not to damage the seals. The body must never exceed 120°C. Slugs and impurities must never penetrate inside the valve.

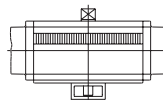
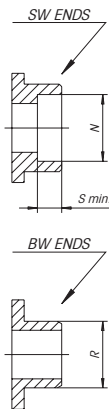
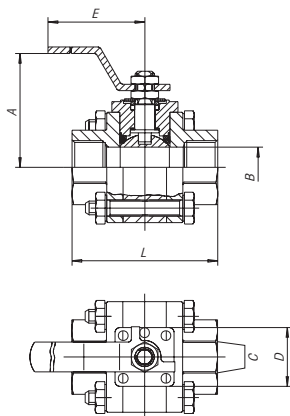

By removing the lever handle, the TITAN valve can be assembled directly with an actuator by means of a bracket, the stem adapter (kit supplied on request) and by eliminating the operation stop (part. 12).

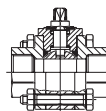

C (Inch)	A	B	C	D	E	L	N	R	S	ISO 5211	weight in gr. FF
1/4"	49	10.9	4.7	36	95.5	61	17.8	18	9.7	F03	630
3/8"	49	12.7	4.7	36	95.5	61	17.8	18	9.7	F03	630
1/2"	63	16	5	36	120.5	71	22	22.5	12.7	F03	860
3/4"	63	19.6	5	36	120.5	81.5	27.3	28.2	12.7	F03	1450
1"	68	25	8	42	162.5	91.5	34	34.5	12.7	F04	2810
1 1/4"	80.5	32	8	42	162.5	114.5	42.8	43.5	12.7	F04	3810
1 1/2"	85	38.1	9.5	50	203	122	48.9	49.5	12.7	F05	5080
2"	97.5	50.8	9.5	50	203	142.7	61.4	61.5	15.8	F05	6580

BREAKAWAY TORQUES in Nm

DN size	10	15	20	25	32	40	50
	1/4"	3/8"	1/2"	3/4"	1"	1 1/4"	1 1/2"
0	10	10	12	16	20	32	55
64	15	15	20	24	27	52	98
105	18	18	23	25	29	80	125
140	19	19	24.5	26	31		

Nm

The values in Nm may vary as a function of the seals material, temperature and type of medium. For a firm operation of the various types of actuators, in the different working conditions it is necessary to consider a safety factor of 1.5. During operation, with frequent open and close cycles, the operating torque can decrease considerably in comparison with the initial breakaway torque.

PRESSURE/TEMPERATURE DIAGRAM

At each pressure level corresponds the admissible temperature level.

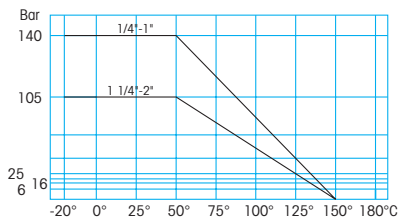

LOSS OF HEAD DIAGRAM/FLOW RATE

The Kv value is the flow rate causing a pressure drop of 1 bar

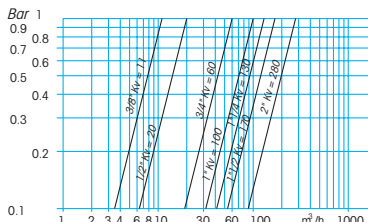

ARGOS

3-PIECE BALL VALVE – FULL BORE WITH **DOUBLE ACTING** PNEUMATIC ACTUATOR

ACTUATOR FEATURES

- Rotation angle: 90°
- Standard version for temperature between -20°C and + 90°C
- Supply maximum pressure: 10 bar (8bar for DNA045)
- Nominal pressure: 5,62 bar
- Supply medium: dry filtered compressed air, not necessarily lubricated
- Lubrication: in such a case use a non-detergent or NBR compatible oil

STANDARD VALVE FEATURES

- Working temperature: from -20°C to +150°C
- Working pressure: PN140 from 1/4" to 1", PN100 from 1 1/4 to 2"
- CONNECTIONS: F/F UNI-ISO 7/1 Rp – DIN 2999 parallel GAS
F/F NPT
SW ANSI B16.11 socket weld
BW ANSI B16.25 butt weld sch. 40
- BLOW-OUT PROOF stem with antistatic device
- For general applications and special versions see technical table of manual valve
- In the below table the part number and the valve code refer to the standard valve version F/F UNI ISO 7/1 Rp – DIN 2999 parallel GAS



SIZE	PART NUMBER	weight in gr.	A	B	C	E	F	Cl oz.	L	M	N	ACTUATOR code	VALVE code	MOUNTING KIT code
1/4"	D71AA20200	1240	110	53	68	21	153	20.5	61	42	10.9	DNA045AZ00	3806X202	K1GA0002
3/8"	D71AA20300	1240	110	53	68	21	153	23.5	61	42	12.7	DNA045AZ00	3806X203	K1GA0002
1/2"	D71AA20400	1825	127	59	74	26	173.5	29.5	71	52	16	DGA052AX00	3806X204	K1GA0304
3/4"	D71AA20500	2475	127	59	74	30	178.5	35	81.5	59.5	19.6	DGA052AX00	3806X205	K1GA0305
1"	D71AA20600	4575	133	70	88	36	198.5	43	91.5	72	25	DGA063AX00	3806X206	K1GA0406
1 1/4"	D71AA20700	5675	133	70	88	40	202	53	114.5	79.5	22	DGA063AX00	3806X207	K1GA0407
1 1/2"	D71AA20800	7730	132	83	100	45	227	61	122	90	38.1	DGA075AX00	3806X208	K1GA0308
2"	D71AA20900	9985	182	91	108	50,5	243.5	76	142.7	101	50.8	DGA083AX00	3806X209	K1GA0308

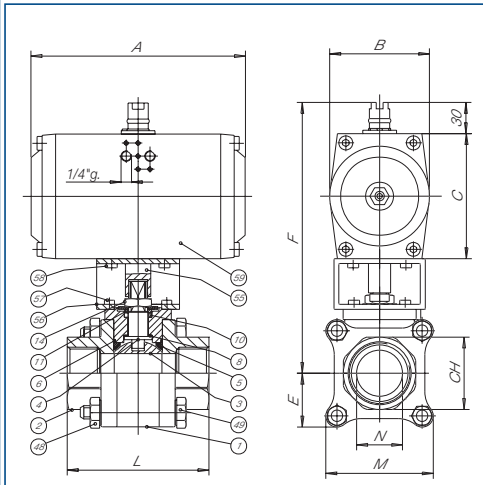

LIST OF VALVE COMPONENTS AND MATERIALS

REF.	PART	QTY	MATERIAL
1	BODY	1	A216-WCB
2	FEMALE END	2	A216-WCB
3	BALL	1	AINI 316
4	STEM	1	AINI 316
5	SEAT	2	PTFE
6	SIDE SEALING RING	2	PTFE
8	UPPER RING	1	PTFE
10	UPPER SEAL	1	PTFE
11	PACKING GLAND	1	AINI 316
14	STEM RETAINING NUT	1	AINI 304
48	BOLT	4	S.S.
49	NUT	4	S.S.
55	ACTUATOR SHAFT	1	C.S.
56	BRACKET	1	C.S.
57	BRACKET/VALVE SCREW	4	8.8
58	BRACKET/ACTUATOR SCREW	4	8.8
59	ACTUATOR	1	

For accessories see relevant catalogue sheet

ARGOS

3-PIECE BALL VALVE – FULL BORE WITH **SPRING RETURN** PNEUMATIC ACTUATOR

ACTUATOR FEATURES

- Rotation angle: 90°
- Standard version for temperature between -20°C and + 90°C
- Supply maximum pressure: 10 bar
- Nominal pressure: 5,62 bar
- Supply medium: dry filtered compressed air, not necessarily lubricated
- Lubrication: in such a case use a non-detergent or NBR compatible oil
- STANDARD: **SPRING CLOSURES/AIR OPENS**, clockwise automatic closing

STANDARD VALVE FEATURES

- Working temperature: from -20°C to +150°C
- Working pressure: PN140 from 1/4" to 1", PN100 from 1"1/4 to 2"
- CONNECTIONS: F/F UNI-ISO 7/1 Rp – DIN 2999 parallel GAS
F/F NPT
SW ANSI B16.11 socket weld
BW ANSI B16.25 butt weld sch. 40
- BLOW-OUT PROOF stem with antistatic device
- For general applications and special versions see technical table of manual valve
- In the below table the part number and the valve code refer to the standard valve version F/F UNI ISO 7/1 Rp – DIN 2999 parallel GAS



SIZE	PART NUMBER	weight in gr.	A	B	C	E	F	Cl. ord.	L	M	N	ACTUATOR code	VALVE code	MOUNTING KIT code
1/4"	S71AA20200	2320	133	70	88	21	183	20.5	61	42	10.9	SGA0634X00	3806X202	K1GA0102
3/8"	S71AA20300	2320	133	70	88	21	183	23.5	61	42	12.7	SGA0634X00	3806X203	K1GA0102
1/2"	S71AA20400	3345	132	83	100	26	199.5	29.5	71	52	16	SGA0754X00	3806X204	K1GA0404
3/4"	S71AA20500	3995	132	83	100	30	204.5	35	81.5	59.5	19.6	SGA0754X00	3806X205	K1GA0405
1"	S71AA20600	6135	182	91	108	36	218.5	43	91.5	72	25	SGA0834X00	3806X206	K1GA0506
1 1/4"	S71AA20700	7235	182	91	108	40	222	53	114.5	79.5	32	SGA0834X00	3806X207	K1GA0507
1 1/2"	S71AA20800	11800	222	120	140	45	267	61	122	90	38.1	SNA1104X00	3806X208	K1GA0408
2"	S71AA20900	13250	222	120	140	50,5	275.5	76	142.7	101	50.8	SNA1104X00	3806X209	K1GA0408

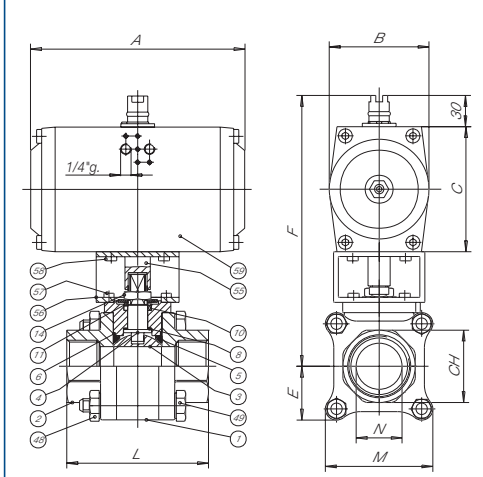

LIST OF VALVE COMPONENTS AND MATERIALS

REF.	PART	QTY	MATERIAL
1	BODY	1	A216-WCB
2	FEMALE END	2	A216-WCB
3	BALL	1	AISI 316
4	STEM	1	AISI 316
5	SEAT	2	PTFE
6	SIDE SEALING RING	2	PTFE
8	UPPER RING	1	PTFE
10	UPPER SEAL	1	PTFE
11	PACKING GLAND	1	AISI 316
14	STEM RETAINING NUT	1	AISI 304
48	BOLT	4	S.S.
49	NUT	4	S.S.
55	ACTUATOR SHAFT	1	C.S.
56	BRACKET	1	C.S.
57	BRACKET/VALVE SCREW	4	8.8
58	BRACKET/ACTUATOR SCREW	4	8.8
59	ACTUATOR	1	

For accessories see relevant catalogue sheet

MOON AISI 316

WAFER BALL VALVE – FULL BORE

MAIN STANDARD FEATURES

- CONSTRUCTION: AISI 316
- General prescriptions: BS 5351
- Certifications: FIRE SAFE to: BS 6755 - API 6 FA - API 607
DVGW for gas
TÜV for TA Luft
- DIAMETER: from DN 15- to DN 100
(for DN 100 to DN 200 see SELENE valve)
- PRESSURES: PN 16/40 from DN 15 to DN 32 body machined from bar
PN 16 from DN 40 to DN 100 body from casting
- TEMPERATURE LIMITS: from -20°C to +180°C
- CONNECTIONS with flanges: UNI 2223-2229 and DIN 2501 BL.1
- FLANGE DRILLING: METRIC
- With contained ball up to DN25
- BLOW-OUT PROOF stem with antistatic device (from DN40)
- WRAPPING SEATS
- TRIPLE stem-parking with labyrinth effect and automatic adjustment by Belleville washers
- ISO 5211 mounting plate for actuators
- NON-WETTED parts in stainless steel
- OPERATION device: lever handle



STANDARD PART NUMBERS

Art. 2871

standard

SPECIAL EXECUTIONS

- 15% GLASS-FILLED PTFE with temperature limits -20°C + 195°C
- PTFE+CARBOGRAPHITE with temperature limits -20°C + 210°C
- Integral seats in PTFE from DN15 to DN100
- From DN 40 to DN 100 PN 25/40 from bar
- From 1/2" to 4" ANSI 150: through drilled flanges
- Reduction gear with manual operation
- Stem extensions: 50 mm or 100 mm
- Yellow lever handle for gas
- Heating jacket (see MOON CR series)
- Drilled ball and unidirectional valve
- Degreased version
- Antistatic device from DN15 to DN32
- On request the valve is available with ATEX certificate
- For further special requests please consult our technical/commercial service

GENERAL APPLICATIONS

Use as an ON-OFF valve for: chemical products, food plants, distribution lines for gas, air, water. Suitable for vacuum 1·10⁻³ STD CC, steam up to +195°C with PTFE+CARBOGRAPHITE and for industrial installations in general.

Thanks to its reduced face to face dimensions and its intrinsic features it offers wide applications in new projects also as an alternative to the split body valve.

For special utilizations ascertain the compatibility with process features and the corrosion resistance also by the relevant table.

LIST OF COMPONENTS AND MATERIALS

REF.	PART	MATERIAL	DIN MAT.	QTY
1	BODY	AISI 316/CF8M	1.4408/1.4401	1
2	THREADED LOCKING RING	AISI 316	1.4401	1
3	BALL	AISI 316	1.4401	1
4	STEM	AISI 316	1.4401	1
5	SEAT	PTFE		2
6	SIDE SEALING RING	PTFE		1
7	O-RING	NBR		1
8	UPPER RING	PTFE		2
9	STEM O-RING	VITON		1
10	UPPER SEALING COUPLE	PTFE		1
11	PACKING GLAND	AISI 304	1.4301	1
12	OPERATION STOP	S.S.		1
13	BELLEVILLE WASHERS	50CrV4		2
14	STEM RETAINING NUT	S.S.		1
15	FIXING NUT PLATE	AISI 304	1.4301	1
17	LOCKING NUT	S.S.		1
18	LEVER HANDLE	S.S.		1
19	OPERATION STOP SCREW	S.S.		1

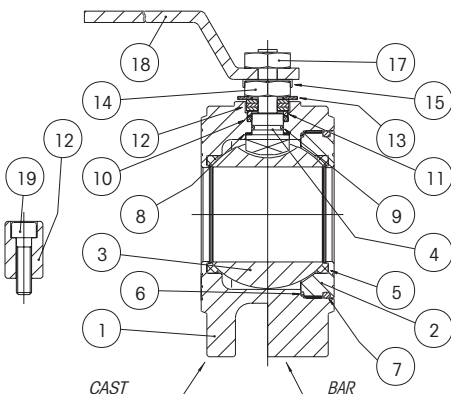

MOON AISI 316

WAFER BALL VALVE - FULL BORE

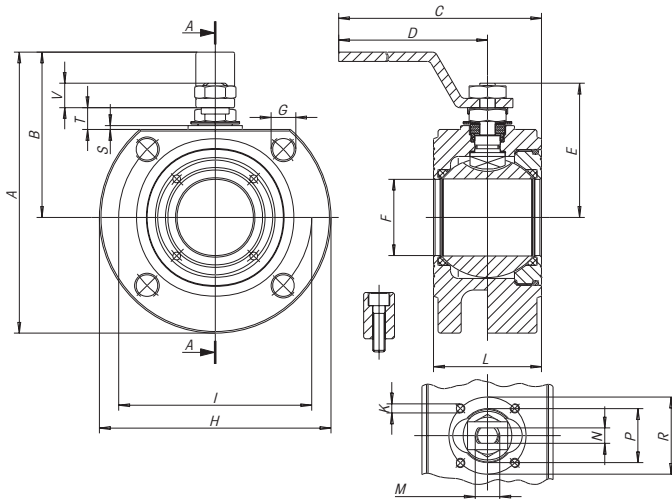

FLANGE DRILLINGS UNI2223-67

SIZE	A	B (PN40)	C (PN16)
DN15	M12	14	0
DN20	M12	16	0
DN25	M12	16	0
DN32	M16	18	0
DN40	M16	18	13
DN50	M16	18	15
DN65	M16	20	15
DN80	M16	24	17
DN100	M16	20	17
DN100	M20	24	0

FLANGE DRILLINGS ANSI 150

SIZE	A	B (PN40)	C (PN16)
DN15	1/2"	13	0
DN20	1/2"	14	0
DN25	1/2"	16	0
DN32	1/2"	17	0
DN40	1/2"	19	0
DN50	5/8"	20	(*) 18.4 (17.4)
DN65	5/8"	24	(*) 18.4 (20.8)
DN80	5/8"	24	(*) 18.4 (22.2)
DN100	5/8"	24	(*) 18.4 (22.2)

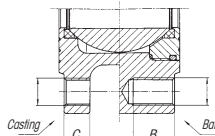

SIZE	A	B	C	D	E	F	G	H	K	I	L	M	N	P	R	S	T	V	N Holes	PN	ISO	Weight in gr.
DN15	110	65	160	140	48	15	M12	90	M5	65	35	M10	6	25	36	2	8	9	4	40	F03	1345
DN20	120	70	160	140	51	20	M12	100	M5	75	38	M10	6	25	36	2	8	9	4	40	F03	1810
DN25	137	82	200	180	62.5	25	M12	110	M5	85	43	M12	8	30	42	2	11.5	11.5	4	40	F04	2505
DN32	150	85	205	180	67	32	M16	130	M5	100	50	M12	8	30	42	2	9.5	11.5	4	40	F04	3995
DN40	172	102	260	230	80	40	M16	140	M6	110	60	M16	10	35	50	2.5	14	16	4	16	F05	4190
DN50	185	110	265	230	87	50	M16	165	M6	125	70	M16	10	35	50	2.5	14	16	4	16	F05	5790
DN65	225	137.5	400	350	119.5	65	M16	185	M8	145	95	M22	14	55	70	3	18.7	20.8	4	16	F07	10200
DN80	245	150	410	350	129.5	78	M16	200	M8	160	118	M22	14	55	70	3	18.7	20.8	8	16	F07	13700
DN100	275	165	580	508	148.5	96	M16	220	M10	180	140	M27	16	70	102	3	22.2	25.3	8	16	F10	20000

For DN 125 to DN 200 see "SELENE" split body wafer valve

BREAKAWAY TORQUES in Nm

DN size	15	20	25	32	40	50	65	80	100
0	4	7	10	16	25	35	55	75	150
16	4.8	8.5	11.3	19	28	39	59	84.5	168
25	5.2	9.1	12	20.5	29.5	41.5	62.5	92	180
40	6	10.5	13	22.5	31.5	44	67	99	195

Nm

The values in Nm may vary as a function of the seals material, temperature and type of medium. For a firm operation of the various types of actuators, in the different working conditions it is necessary to consider a safety factor of 1.5. During operation, with frequent open and close cycles, the operating torque can decrease considerably in comparison with the initial breakaway torque.

PRESSURE/TEMPERATURE DIAGRAM

At each pressure level corresponds the admissible temperature level.

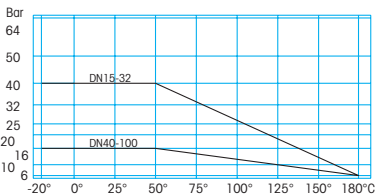

LOSS OF HEAD DIAGRAM/FLOW RATE

The Kv value is the flow rate causing a pressure drop of 1 bar

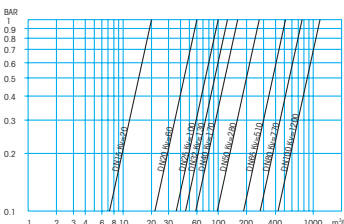

MOON AISI 316

WAFER BALL VALVE – FULL BORE WITH **DOUBLE ACTING** PNEUMATIC ACTUATOR

ACTUATOR FEATURES

- Rotation angle: 90°
- Standard version for temperature between -20°C and +90°C
- Supply maximum pressure: 10 bar (8bar for DNA045)
- Nominal pressure: 5,62 bar
- Supply medium: dry filtered compressed air, not necessarily lubricated
- Lubrication: in such a case use a non-detergent or NBR compatible oil

STANDARD VALVE FEATURES

- General prescriptions: BS 5351, Fire safe BS 6755-API 6 FA- API 607
- Working temperature: from -20°C to +180°C
- Maximum working pressure with actuator: **PN 16** (PN 25 and 40 on request)
- CONNECTIONS with flanges: UNI 2223-2229 AND DIN 2501 BL.1
- FLANGE DRILLING: METRIC
- BLOW-OUT PROOF stem with antistatic device
- For general applications and special versions see technical table of manual valve
- In the below table the part number and the valve code refer to the standard valve **PN 16** and **PN 40** where applicable



SIZE	PART NUMBER	weight in gr.	A	B	C	E	F	G	I	L	PN	ACTUATOR code	VALVE code	MOUNTING KIT code
DN15	D41AA60400	1880	110	53	68	167	45	M12	65	35	40	DNA045AZ00	V415X604	K1GA0004
DN20	D41AA60500	2360	110	53	68	170	50	M12	75	38	40	DNA045AZ00	V415X605	K1GA0004
DN25	D41AA60600	3370	127	59	74	202	55	M12	85	43	40	DGA052AX00	V415X606	K1GA0006
DN32	D41AA60700	5450	133	70	88	222	65	M16	100	50	40	DGA063AX00	V415X607	K1GA0007
DN40	D41AA60800	7640	132	83	100	238	70	M16	110	60	16	DGA075AX00	V415X608	K1GA0008
DN50	D41AA60900	10000	182	91	108	253	75	M16	125	70	16	DGA083AX00	V415X609	K1GA0008
DN65	D41AA61000	18715	203	100	117	294	87.5	M16	145	95	16	DGA092AX00	V415X610	K1GA0010
DN80	D41AA61100	24785	222	120	140	327	95	M16	160	118	16	DNA110AX00	V415X611	K1GA0011
DN100	D41AA61200	40800	300	137	160	378	110	M16	180	140	16	DNA127AX00	V415X612	K1GA0012

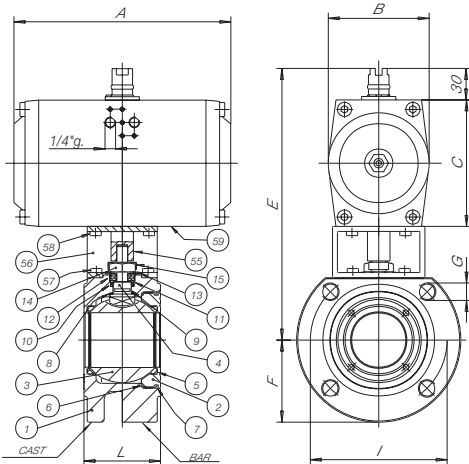

LIST OF VALVE COMPONENTS AND MATERIALS

REF.	PART	QTY	MATERIAL
1	BODY	1	AISI 316/CF8M
2	THREADED LOCKING RING	1	AISI 316
3	BALL	1	AISI 316
4	STEM	1	AISI 316
5	SEAT	2	PTFE
6	SIDE SEALING RING	1	PTFE
7	O-RING	1	NBR
8	UPPER SEALING RING	2	PTFE
9	STEM O-RING	1	VITON
10	UPPER SEALING COUPLE	1	PTFE
11	PACKING GLAND	1	AISI 304
12	WASHER	1	S.S.
13	BELLEVILLE WASHERS	2	50CrV4
14	STEM RETAINING NUT	1	S.S.
15	FIXING NUT PLATE	1	AISI 304
55	ACTUATOR SHAFT	1	C.S.
56	BRACKET	1	C.S.
57	BRACKET/VALVE SCREW	4	8.8
58	BRACKET/ACTUATOR SCREW	4	8.8
59	ACTUATOR	1	

For accessories see relevant catalogue sheet

MOON AISI 316

WAFER BALL VALVE – FULL BORE WITH **SPRING RETURN PNEUMATIC ACTUATOR**

ACTUATOR FEATURES

- Rotation angle: 90°
- Standard version for temperature between -20°C and + 90°C
- Supply maximum pressure: 10 bar (8bar for DNA045)
- Nominal pressure: 5,62 bar
- Supply medium: dry filtered compressed air, not necessarily lubricated
- Lubrication: in such a case use a non-detergent or NBR compatible oil

STANDARD VALVE FEATURES

- General prescriptions: BS 5351, Fire safe BS 6755-API 6 FA- API 607
- Working temperature: from -20°C to +180°C
- Maximum working pressure with actuator: **PN 16** (PN 25 and 40 on request)
- CONNECTIONS with flanges: UNI 2223-2229 AND DIN 2501 BL.1
- FLANGE DRILLING: METRIC
- BLOW-OUT PROOF stem with antistatic device
- For general applications and special versions see technical table of manual valve
- In the below table the part number and the valve code refer to the standard valve **PN 16** and **PN 40** where applicable



SIZE	PART NUMBER	weight in gr.	A	B	C	E	F	G	I	L	PN	ACTUATOR code	VALVE code	CÓD. KIT
DN15	S41AA60400	2320	127	59	74	183	45	M12	65	35	40	SGA0524X00	V415X604	K1GA0104
DN20	S41AA60500	3360	133	70	88	200	50	M12	75	38	40	SGA0634X00	V415X605	K1GA0005
DN25	S41AA60600	4780	132	83	100	228	55	M12	85	43	40	SGA0754X00	V415X606	K1GA0106
DN32	S41AA60700	6900	182	91	108	242	65	M16	100	50	40	SGA0834X00	V415X607	K1GA0107
DN40	S41AA60800	9370	203	100	117	255	70	M16	110	60	16	SGA0924X00	V415X608	K1GA0108
DN50	S41AA60900	13020	222	120	140	285	75	M16	125	70	16	SNA1104X00	V415X609	K1GA0108
DN65	S41AA61000	25120	300	137	160	337	87.5	M16	145	95	16	SNA1274X00	V415X610	K1GA0110
DN80	S41AA61100	38390	380	172	198	395	95	M16	160	118	16	SNA1604X00	V415X611	K1GA0111
DN100	S41AA61200	51270	380	172	198	426	110	M16	180	140	16	SNA1605X00	V415X612	K1GA0112

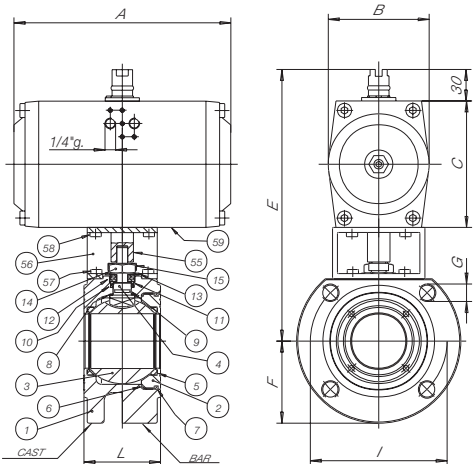

LIST OF VALVE COMPONENTS AND MATERIALS

REF.	PART	QTY	MATERIAL
1	BODY	1	AISI 316/CF8M
2	THREADED LOCKING RING	1	AISI 316
3	BALL	1	AISI 316
4	STEM	1	AISI 316
5	SEAT	2	PTFE
6	SIDE SEALING RING	1	PTFE
7	O-RING	1	NBR
8	UPPER SEALING RING	2	PTFE
9	STEM O-RING	1	VITON
10	UPPER SEALING COUPLE	1	PTFE
11	PACKING GLAND	1	AISI 304
12	WASHER	1	S.S.
13	BELLEVILLE WASHERS	2	50CrV4
14	STEM RETAINING NUT	1	S.S.
15	FIXING NUT PLATE	1	AISI 304
55	ACTUATOR SHAFT	1	C.S.
56	BRACKET	1	C.S.
57	BRACKET/VALVE SCREW	4	8.8
58	BRACKET/ACTUATOR SCREW	4	8.8
59	ACTUATOR	1	

For accessories see relevant catalogue sheet

MOON AISI 304

WAFER BALL VALVE – FULL BORE

MAIN STANDARD FEATURES

- CONSTRUCTION: AISI 304
- General prescriptions: BS 5351
- Certifications: FIRE SAFE to: BS 6755 - API 6 FA - API 607
DVGW for gas
TÜV for TA Luft
- DIAMETER: from DN 15 to DN 100
- PRESSURES: PN 16/40 from DN 15 to DN 32 body machined from bar
PN 16 from DN 40 to DN 100 body from casting
- TEMPERATURE LIMITS: from -20°C to +180°C
- CONNECTIONS with flanges: UNI 2223-2229 and DIN 2501 BL.1
- FLANGE DRILLING: METRIC
- With contained ball up to DN25
- BLOW-OUT PROOF stem with antistatic device (from DN40)
- WRAPPING SEATS
- TRIPLE stem-packing with labyrinth effect and automatic adjustment by Belleville washers
- ISO 5211 mounting plate for actuators
- NON-WETTED parts in stainless steel
- OPERATION device: lever handle



STANDARD PART NUMBERS

Art. 2861

standard

GENERAL APPLICATIONS

Use as an ON-OFF valve for: chemical products, food plants, distribution lines for gas, air, water. Suitable for vacuum 1·10⁻³ STD CC, steam up to +195°C with PTFE+CARBOGRAPHITE and for industrial installations in general.

Thanks to its reduced face to face dimensions and its intrinsic features it offers wide applications in new projects also as an alternative to the split body valve.

For special utilizations ascertain the compatibility with process features and the corrosion resistance also by the relevant table.

SPECIAL EXECUTIONS

- 15% GLASS-FILLED PTFE with temperature limits -20°C + 195°C
- PTFE+CARBOGRAPHITE with temperature limits -20°C + 210°C
- Integral seats in PTFE from DN15 TO DN100
- From DN40 to DN100 PN25/40 from bar
- From 1/2" to 4" ANSI 150: through drilled flanges
- Reduction gear with manual operation
- Stem extensions: 50 mm or 100 mm
- Yellow lever handle for gas
- Heating jacket (see MOON CR series)
- Drilled ball and unidirectional valve
- Degreased version
- Antistatic device from DN15 to DN32
- On request the valve is available with ATEX certificate
- For further special requests please consult our technical/commercial service

LIST OF COMPONENTS AND MATERIALS

REF.	PART	MATERIAL	DIN MAT.	QTY
1	BODY	AISI 304/CF8	1.4308	1
2	THREADED LOCKING RING	AISI 304	1.4301	1
3	BALL	AISI 304	1.4301	1
4	STEM	AISI 304	1.4301	1
5	SEAT	PTFE		2
6	SIDE SEALING RING	PTFE		1
7	O-RING	NBR		1
8	UPPER RING	PTFE		2
9	STEM O-RING	VITON		1
10	UPPER SEALING COUPLE	PTFE		1
11	PACKING GLAND	AISI 304	1.4301	1
12	OPERATION STOP	AISI 304	1.4301	1-3
13	BELLEVILLE WASHERS	AISI 301	1.4310	2
14	STEM RETAINING NUT	AISI 304	1.4301	1
15	FIXING NUT PLATE	AISI 304	1.4301	1
17	LOCKING NUT	AISI 304	1.4301	1
18	LEVER HANDLE	AISI 304	1.4301	1
19	OPERATION STOP SCREW	AISI 304	1.4301	1

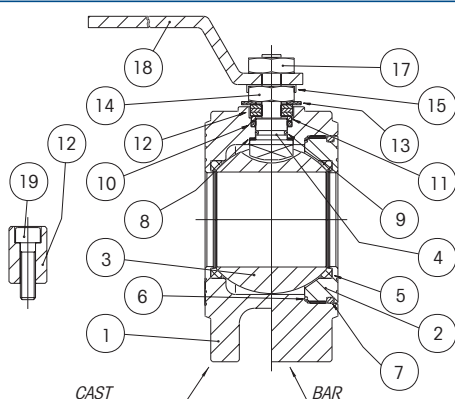

MOON AISI 304

WAFER BALL VALVE - FULL BORE

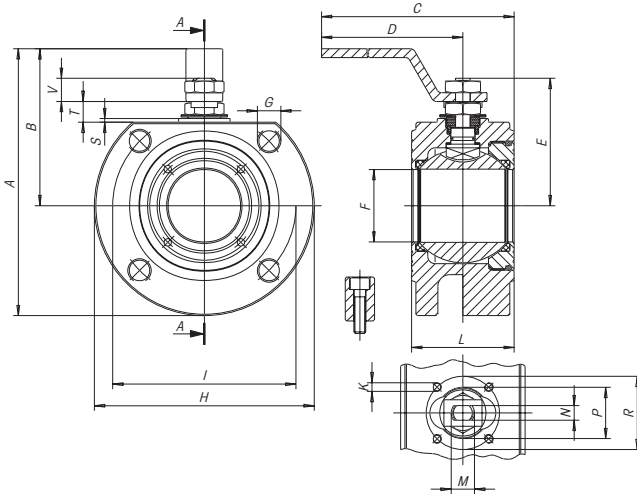

FLANGE DRILLINGS UNI2223-67

SIZE	A	B (PN40)	C (PN16)
DN15	M12	14	0
DN20	M12	16	0
DN25	M12	16	0
DN32	M16	18	0
DN40	M16	18	13
DN50	M16	18	15
DN65	M16	20	15
DN80	M16	24	17
DN100	M16	20	17
DN100	M20	24	0

FLANGE DRILLINGS ANSI 150

SIZE	A	B (PN40)	C (PN16)
DN15	1/2"	13	0
DN20	1/2"	14	0
DN25	1/2"	16	0
DN32	1/2"	17	0
DN40	1/2"	19	0
DN50	5/8"	20	(*) 18.4 (17.4)
DN65	5/8"	24	(*) 18.4 (20.6)
DN80	5/8"	24	(*) 18.4 (22.2)
DN100	5/8"	24	(*) 18.4 (22.2)

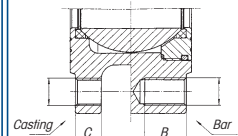

SIZE	A	B	C	D	E	F	G	H	K	I	L	M	N	P	R	S	T	V	N Holes	PN	ISO	Weight in gr.
DN15	110	65	160	140	48	15	M12	90	M5	65	35	M10	6	25	36	2	8	9	4	40	F03	1345
DN20	120	70	160	140	51	20	M12	100	M5	75	38	M10	6	25	36	2	8	9	4	40	F03	1810
DN25	137	82	200	180	62.5	25	M12	110	M5	85	43	M12	8	30	42	2	11.5	11.5	4	40	F04	2505
DN32	150	85	205	180	67	32	M16	130	M5	100	50	M12	8	30	42	2	9.5	11.5	4	40	F04	3995
DN40	172	102	260	230	80	40	M16	140	M6	110	60	M16	10	35	50	2.5	14	16	4	16	F05	4190
DN50	185	110	265	230	87	50	M16	165	M6	125	70	M16	10	35	50	2.5	14	16	4	16	F05	5790
DN65	225	137.5	400	350	119.5	65	M16	185	M8	145	95	M22	14	55	70	3	18.7	20.8	4	16	F07	10200
DN80	245	150	410	350	129.5	78	M16	200	M8	160	118	M22	14	55	70	3	18.7	20.8	8	16	F07	13700
DN100	275	165	580	508	148.5	96	M16	220	M10	180	140	M27	16	70	102	3	22.2	25.3	8	16	F10	20000

BREAKAWAY TORQUES in Nm

DN size	15	20	25	32	40	50	65	80	100
0	4	7	10	16	25	35	55	75	150
16	4.8	8.5	11.3	19	28	39	59	84.5	168
25	5.2	9.1	12	20.5	29.5	41.5	62.5	92	180
40	6	10.5	13	22.5	31.5	44	67	99	195

The values in Nm may vary as a function of the seals material, temperature and type of medium. For a firm operation of the various types of actuators, in the different working conditions it is necessary to consider a safety factor of 1.5. During operation, with frequent open and close cycles, the operating torque can decrease considerably in comparison with the initial breakaway torque.

PRESSURE/TEMPERATURE DIAGRAM

At each pressure level corresponds the admissible temperature level.

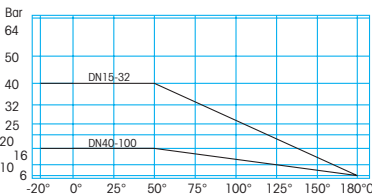

LOSS OF HEAD DIAGRAM/FLOW RATE

The Kv value is the flow rate causing a pressure drop of 1 bar

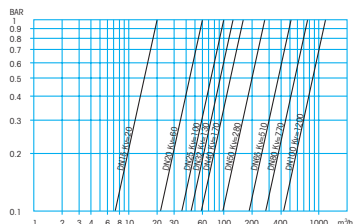

MOON AISI 304

WAFER BALL VALVE – FULL BORE WITH **DOUBLE ACTING** PNEUMATIC ACTUATOR

ACTUATOR FEATURES

- Rotation angle: 90°
- Standard version for temperature between -20°C and + 90°C
- Supply maximum pressure: 10 bar (8bar for DNA045)
- Nominal pressure: 5,62 bar
- Supply medium: dry filtered compressed air, not necessarily lubricated
- Lubrication: in such a case use a non-detergent or NBR compatible oil

STANDARD VALVE FEATURES

- General prescriptions: BS 5351, Fire safe BS 6755-API 6 FA- API 607
- Working temperature: from -20°C to +180°C
- Maximum working pressure with actuator: **PN 16** (PN 25 and 40 on request)
- CONNECTIONS with flanges: UNI 2223-2229 AND DIN 2501 BL.1
- FLANGE DRILLING: METRIC
- BLOW-OUT PROOF stem with antistatic device
- For general applications and special versions see technical table of manual valve
- In the below table the part number and the valve code refer to the standard valve **PN 16** and PN 40 where applicable



SIZE	PART NUMBER	weight in gr.	A	B	C	E	F	G	I	L	PN	ACTUATOR code	VALVE code	MOUNTING KIT code
DN15	D81AA60400	1880	110	53	68	167	45	M12	65	35	40	DNA045AZ00	V861X604	K1GA0004
DN20	D81AA60500	2360	110	53	68	170	50	M12	75	38	40	DNA045AZ00	V861X605	K1GA0004
DN25	D81AA60600	3370	127	59	74	202	55	M12	85	43	40	DGA052AX00	V861X606	K1GA0006
DN32	D81AA60700	5450	133	70	88	222	65	M16	100	50	40	DGA063AX00	V861X607	K1GA0007
DN40	D81AA60800	7640	132	83	100	238	70	M16	110	60	16	DGA075AX00	V861X608	K1GA0008
DN50	D81AA60900	10000	182	91	108	253	75	M16	125	70	16	DGA083AX00	V861X609	K1GA0008
DN65	D81AA61000	18715	203	100	117	294	87.5	M16	145	95	16	DGA092AX00	V861X610	K1GA0010
DN80	D81AA61100	24785	222	120	140	327	95	M16	160	118	16	DNA110AX00	V861X611	K1GA0011
DN100	D81AA61200	40800	300	137	160	378	110	M16	180	140	16	DNA127AX00	V861X612	K1GA0012

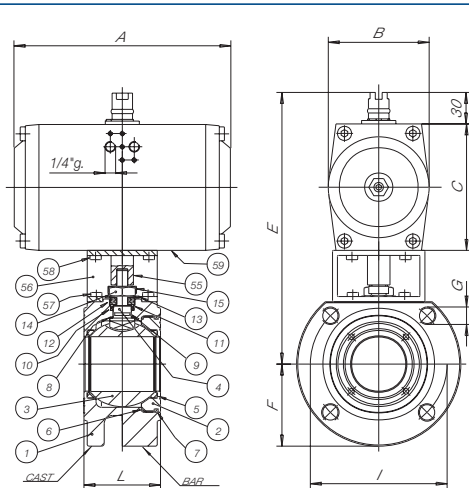

LIST OF VALVE COMPONENTS AND MATERIALS

REF.	PART	QTY	MATERIAL
1	BODY	1	AISI 304/CF8
2	THREADED LOCKING RING	1	AISI 304
3	BALL	1	AISI 304
4	STEM	1	AISI 304
5	SEAT	2	PTFE
6	SIDE SEALING RING	1	PTFE
7	O-RING	1	NBR
8	UPPER SEALING RING	2	PTFE
9	STEM O-RING	1	VITON
10	UPPER SEALING COUPLE	1	PTFE
11	PACKING GLAND	1	AISI 304
12	WASHER	1	AISI 304
13	BELLEVILLE WASHERS	2	AISI 301
14	STEM RETAINING NUT	1	AISI 304
15	FIXING NUT PLATE	1	AISI 304
55	ACTUATOR SHAFT	1	C.S.
56	BRACKET	1	C.S.
57	BRACKET/VALVE SCREW	4	8.8
58	BRACKET/ACTUATOR SCREW	4	8.8
59	ACTUATOR	1	

For accessories see relevant catalogue sheet

MOON AISI 304

WAFER BALL VALVE – FULL BORE WITH **SPRING RETURN** PNEUMATIC ACTUATOR

ACTUATOR FEATURES

- Rotation angle: 90°
- Standard version for temperature between -20°C and + 90°C
- Supply maximum pressure: 10 bar
- Nominal pressure: 5,62 bar
- Supply medium: dry filtered compressed air, not necessarily lubricated
- Lubrication: in such a case use a non-detergent or NBR compatible oil
- STANDARD: **SPRING CLOSES/AIR OPENS**, clockwise automatic closing

STANDARD VALVE FEATURES

- General prescriptions: BS 5351, Fire safe BS 6755-API 6 FA- API 607
- Working temperature: from -20°C to +180°C
- Maximum working pressure with actuator: **PN 16** (PN 25 and 40 on request)
- CONNECTIONS with flanges: UNI 2223-2229 AND DIN 2501 BL.1
- FLANGE DRILLING: METRIC
- BLOW-OUT PROOF stem with antistatic device
- For general applications and special versions see technical table of manual valve
- In the below table the part number and the valve code refer to the standard valve **PN 16** and **PN 40** where applicable



SIZE	PART NUMBER	weight in gr.	A	B	C	E	F	G	I	L	PN	ACTUATOR code	VALVE code	Mounting Kit code
DN15	S81AA60400	2320	127	59	74	183	45	M12	65	35	40	SGA0524X00	V861X604	K1GA0104
DN20	S81AA60500	3360	133	70	88	200	50	M12	75	38	40	SGA0634X00	V861X605	K1GA0005
DN25	S81AA60600	4780	132	83	100	228	55	M12	85	43	40	SGA0754X00	V861X606	K1GA0106
DN32	S81AA60700	6900	182	91	108	242	65	M16	100	50	40	SGA0834X00	V861X607	K1GA0107
DN40	S81AA60800	9370	203	100	117	255	70	M16	110	60	16	SGA0924X00	V861X608	K1GA0108
DN50	S81AA60900	13020	222	120	140	285	75	M16	125	70	16	SNA1104X00	V861X609	K1GA0108
DN65	S81AA61000	25120	300	137	160	337	87.5	M16	145	95	16	SNA1274X00	V861X610	K1GA0110
DN80	S81AA61100	38390	380	172	198	395	95	M16	160	118	16	SNA1604X00	V861X611	K1GA0111
DN100	S81AA61200	51270	380	172	198	426	110	M16	180	140	16	SNA1605X00	V861X612	K1GA0112

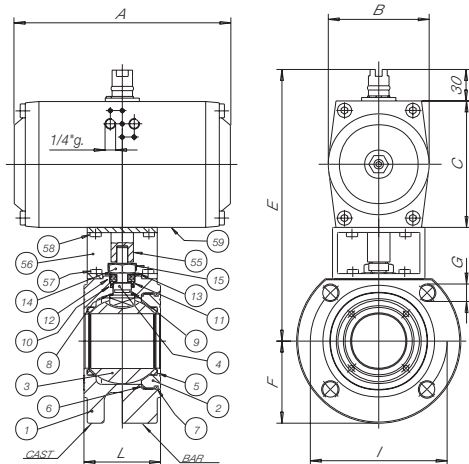

LIST OF VALVE COMPONENTS AND MATERIALS

REF.	PART	QTY	MATERIAL
1	BODY	1	AISI 304/CF8
2	THREADED LOCKING RING	1	AISI 304
3	BALL	1	AISI 304
4	STEM	1	AISI 304
5	SEAT	2	PTFE
6	SIDE SEALING RING	1	PTFE
7	O-RING	1	NBR
8	UPPER SEALING RING	2	PTFE
9	STEM O-RING	1	VITON
10	UPPER SEALING COUPLE	1	PTFE
11	PACKING GLAND	1	AISI 304
12	WASHER	1	AISI 304
13	BELLEVILLE WASHERS	2	AISI 301
14	STEM RETAINING NUT	1	AISI 304
15	FIXING NUT PLATE	1	AISI 304
55	ACTUATOR SHAFT	1	C.S.
56	BRACKET	1	C.S.
57	BRACKET/VALVE SCREW	4	8.8
58	BRACKET/ACTUATOR SCREW	4	8.8
59	ACTUATOR	1	

For accessories see relevant catalogue sheet

MOON A 105

WAFER BALL VALVE - FULL BORE

MAIN STANDARD FEATURES

- CONSTRUCTION: ASTM A 105
- General prescriptions: BS 5351
- Certifications FIRE SAFE to: BS 6755 - API 6 FA - API 607
DVGW for gas
TÜV for TA Luft
- DIAMETER: from DN 15 to DN 100
(for DN 125 to DN 200 see SELENE valve)
- PRESSURES: PN 16/40 from DN 15 to DN 50 and DN 80
PN 16 for DN 65 and DN 100
- TEMPERATURE LIMITS: from -10°C to +180°C
- CONNECTIONS with flanges: UNI 2223-2229 and DIN 2501 BL.1
- FLANGE DRILLING: METRIC
- With contained ball up to DN25
- BLOW-OUT PROOF stem with antistatic device (from DN40)
- WRAPPING SEATS
- TRIPLE stem-packing with labyrinth effect and automatic adjustment by Belleville washers
- ISO 5211 mounting plate for actuators
- OPERATION device: lever handle

SPECIAL EXECUTIONS

- 15% GLASS-FILLED PTFE with temperature limits -10°C + 195°C
- PTFE+CARBOGRAPHITE with temperature limits -10°C + 210°C
- Integral seats in PTFE from DN 15 to DN 100
- DN 65 and DN 100 PN 25/40: metric drilled flanges
- From 1/2" to 4" ANSI 150: through drilled flanges
- Reduction gear with manual operation
- Stem extensions: 50 mm or 100 mm
- Yellow lever handle for gas
- Heating jacket (see MOON CR series)
- Drilled ball and unidirectional valve
- Antistatic device from DN15 to DN32
- On request the valve is available with ATEX certificate
- Body in LF2 up to -20°C
- For further special requests please consult our technical/commercial service

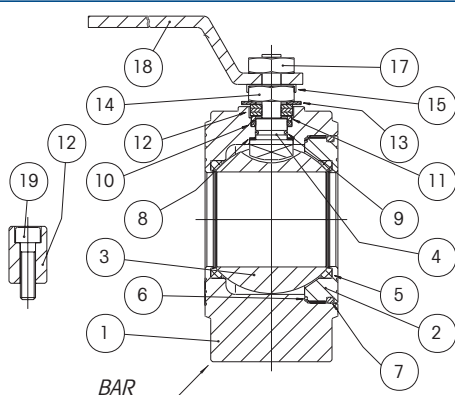

STANDARD PART NUMBERS

Art. 2881

standard

Art. 2891 (PN16)

with ball in brass

GENERAL APPLICATIONS

Use as an ON-OFF valve for: distribution lines for gas, air, water. Suitable for vacuum 1.10⁻³ STD CC, steam up to +195°C with PTFE+CARBOGRAPHITE and for industrial installations in general. Thanks to its reduced face to face dimensions and its intrinsic features it offers wide applications in new projects also as an alternative to the split body valve.

For special utilizations ascertain the compatibility with process features and the corrosion resistance also by the relevant table.

LIST OF COMPONENTS AND MATERIALS

REF.	PART	MATERIAL	DIN MAT.	QTY
1	BODY	ASTM		1
2	THREADED LOCKING RING	ASTM A105		1
3	BALL	See below		1
4	STEM	AISI 304	1.4301	1
5	SEAT	PTFE		2
6	SIDE SEALING RING	PTFE		1
7	O-RING	NBR		1
8	UPPER RING	PTFE		2
9	STEM O-RING	VITON		1
10	UPPER SEALING COUPLE	PTFE		1
11	PACKING GLAND	AISI 304	1.4301	1
12	OPERATION STOP	AISI 304		1
13	BELLEVILLE WASHERS	50CrV4		2
14	STEM RETAINING NUT	C.S.		1
15	FIXING NUT PLATE	AISI 304	1.4301	1
17	LOCKING NUT	C.S.		1
18	LEVER HANDLE	C.S.		1
19	OPERATION STOP SCREW	C.S.		1

Ball: Art. 2881 DN15-32 AISI 316; DN 40-100 AISI 304
Art. 2891 DN15-100 with ball in brass

MOON A 105

WAFER BALL VALVE - FULL BORE

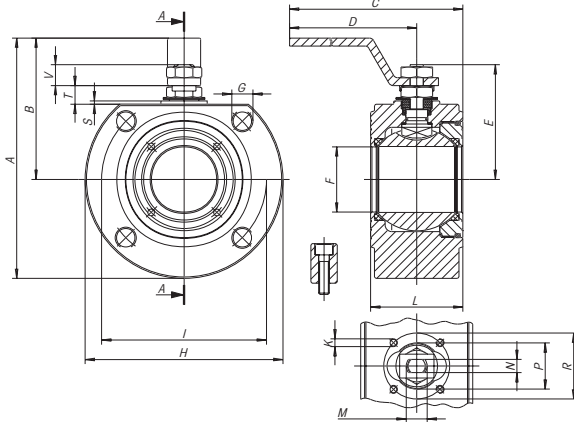

FLANGE DRILLINGS UNI2223-67

SIZE	A	B (PM40)	C (PN16)
DN15	M12	14	0
DN20	M12	16	0
DN25	M12	16	0
DN32	M16	18	0
DN40	M16	18	13
DN50	M16	18	15
DN65	M16	20	15
DN80	M16	24	17
DN100	M16	20	17
DN100	M20	24	0

FLANGE DRILLINGS ANSI 150

SIZE	A	B (PM40)	C (PN16)
DN15	1/2"	13	0
DN20	1/2"	14	0
DN25	1/2"	16	0
DN32	1/2"	17	0
DN40	1/2"	19	0
DN50	5/8"	20	(*) 18.4 (17.4)
DN65	5/8"	24	(*) 18.4 (20.6)
DN80	5/8"	24	(*) 18.4 (22.2)
DN100	5/8"	24	(*) 18.4 (22.2)

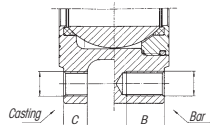

SIZE	A	B	C	D	E	F	G	H	K	I	L	M	N	P	R	S	T	V	N. Holes	PN	ATT.	Weight in gr.
DN15	110	65	160	140	48	15	M12	90	M5	65	35	M10	6	25	36	2	8	9	4	40	F03	1345
DN20	120	70	160	140	51	20	M12	100	M5	75	38	M10	6	25	36	2	8	9	4	40	F03	1810
DN25	137	82	200	180	62.5	25	M12	110	M5	85	43	M12	8	30	42	2	11.5	11.5	4	40	F04	2505
DN32	150	85	205	180	67	32	M16	130	M5	100	50	M12	8	30	42	2	9.5	11.5	4	40	F04	3995
DN40	172	102	260	230	80	40	M16	140	M6	110	60	M16	10	35	50	2.5	14	16	4	40	F05	5540
DN50	185	110	265	230	87	50	M16	150	M6	125	70	M16	10	35	50	2.5	14	16	4	40	F05	7300
DN65	225	137.5	400	350	119.5	65	M16	175	M8	145	95	M22	14	55	70	3	18.7	20.8	4	16	F07	15000
DN65	225	137.5	400	350	119.5	65	M16	175	M8	145	95	M22	14	55	70	3	18.7	20.8	8	40	F07	15000
DN80	245	150	410	350	129.5	78	M16	190	M8	160	118	M22	14	55	70	3	18.7	20.8	8	40	F07	19500
DN100	275	165	580	508	148.5	96	M16	220	M10	180	140	M27	16	70	102	3	22.2	25.3	8	16	F10	31500
DN100	291	173	580	508	156.5	96	M20	235	M10	190	140	M27	16	70	102	3	22.2		8	40	F10	37000

For DN 125 to DN 200 see "SELENE" split body wafer valve

BREAKAWAY TORQUES IN Nm

DN size	15	20	25	32	40	50	65	80	100
PN - bar	0	4	7	10	16	25	35	55	75
	16	4.8	8.5	11.3	19	28	39	59	84.5
	25	5.2	9.1	12	20.5	29.5	41.5	62.5	92
	40	6	10.5	13	22.5	31.5	44	67	99

Nm

The values in Nm may vary as a function of the seals material, temperature and type of medium. For a firm operation of the various types of actuators, in the different working conditions it is necessary to consider a safety factor of 1.5. During operation, with frequent open and close cycles, the operating torque can decrease considerably in comparison with the initial breakaway torque.

PRESSURE/TEMPERATURE DIAGRAM

At each pressure level corresponds the admissible temperature level.

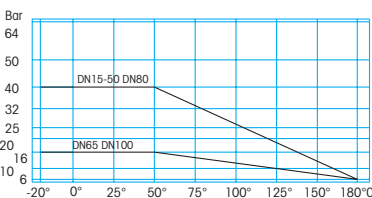

LOSS OF HEAD DIAGRAM/FLOW RATE

The Kv value is the flow rate causing a pressure drop of 1 bar

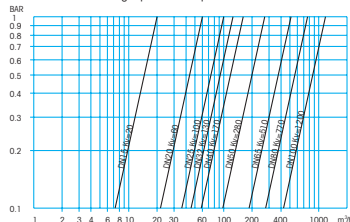

MOON A105

WAFER BALL VALVE – FULL BORE WITH **DOUBLE ACTING** PNEUMATIC ACTUATOR

ACTUATOR FEATURES

- Rotation angle: 90°
- Standard version for temperature between -20°C and + 90°C
- Supply maximum pressure: 10 bar (8bar for DNA045)
- Nominal pressure: 5,62 bar
- Supply medium: dry filtered compressed air, not necessarily lubricated
- Lubrication: in such a case use a non-detergent or NBR compatible oil

STANDARD VALVE FEATURES

- General prescriptions: BS 5351, Fire safe BS 6755-API 6 FA- API 607
- Working temperature: from -20°C to +180°C
- Maximum working pressure with actuator: **PN 16** (PN 25 and 40 on request)
- CONNECTIONS with flanges: UNI 2223-2229 AND DIN 2501 BL.1
- FLANGE DRILLING: METRIC
- BLOW-OUT PROOF stem with antistatic device
- For general applications and special versions see technical table of manual valve
- In the below table the part number and the valve code refer to the standard valve **PN 16** and PN 40 where applicable



SIZE	PART NUMBER	weight in gr.	A	B	C	E	F	G	I	L	PN	ACTUATOR code	VALVE code	MOUNTING KIT code
DN15	D51AA60400	1880	110	53	68	167	45	M12	65	35	40	DNA045AZ00	V515X604	K1GA0004
DN20	D51AA60500	2360	110	53	68	170	50	M12	75	38	40	DNA045AZ00	V515X605	K1GA0004
DN25	D51AA60600	3370	127	59	74	202	55	M12	85	43	40	DGA052AX00	V515X606	K1GA0006
DN32	D51AA60700	5450	133	70	88	222	65	M16	100	50	40	DGA063AX00	V515X607	K1GA0007
DN40	D51AA60800	7640	132	83	100	238	70	M16	110	60	40	DGA075AX00	V515X608	K1GA0008
DN50	D51AA60900	10000	182	91	108	253	75	M16	125	70	40	DGA083AX00	V515X609	K1GA0008
DN65	D51AA61000	18715	203	100	117	294	87.5	M16	145	95	16	DGA092AX00	V515X610	K1GA0010
DN65	D52AA61000	18715	203	100	117	294	87.5	M16	145	95	40	DGA092AX00	V886X610	K1GA0010
DN80	D51AA61100	24785	222	120	140	327	95	M16	160	118	40	DNA110AX00	V515X611	K1GA0011
DN100	D51AA61200	40800	300	137	160	378	110	M16	180	140	16	DNA127AX00	V515X612	K1GA0012
DN100	D52AA61200	47300	300	137	160	386	118	M20	190	140	40	DNA127AX00	V886X612	K1GA0012

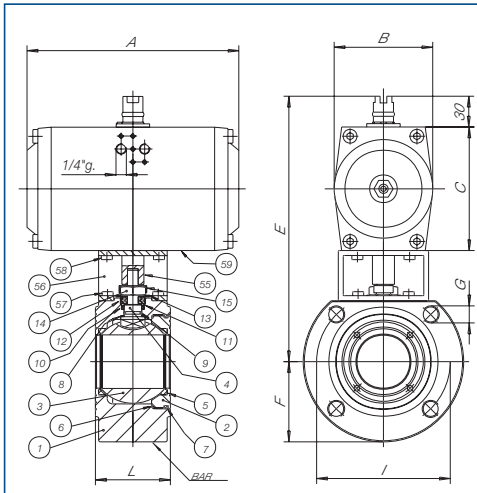

LIST OF VALVE COMPONENTS AND MATERIALS

REF.	PART	QTY	MATERIAL
1	BODY	1	ASTM A105
2	THREADED LOCKING RING	1	ASTM A105
3	BALL	1	AISI 316/AISI 304
4	STEM	1	AISI 304
5	SEAT	2	PTFE
6	SIDE SEALING RING	1	PTFE
7	O-RING	1	NBR
8	UPPER SEALING RING	2	PTFE
9	STEM O-RING	1	VITON
10	UPPER SEALING COUPLE	1	PTFE
11	PACKING GLAND	1	AISI 304
12	WASHER	1	AISI 304
13	BELLEVILLE WASHERS	2	50CrV4
14	STEM RETAINING NUT	1	C.S.
15	FIXING NUT PLATE	1	AISI 304
55	ACTUATOR SHAFT	1	C.S.
56	BRACKET	1	C.S.
57	BRACKET/VALVE SCREW	4	8.8
58	BRACKET/ACTUATOR SCREW	4	8.8
59	ACTUATOR	1	

For accessories see relevant catalogue sheet

MOON A105

WAFER BALL VALVE – FULL BORE WITH **SPRING RETURN** PNEUMATIC ACTUATOR

ACTUATOR FEATURES

- Rotation angle: 90°
- Standard version for temperature between -20°C and + 90°C
- Supply maximum pressure: 10 bar
- Nominal pressure: 5,62 bar
- Supply medium: dry filtered compressed air, not necessarily lubricated
- Lubrication: in such a case use a non-detergent or NBR compatible oil
- STANDARD: **SPRING CLOSES/AIR OPENS**, clockwise automatic closing

STANDARD VALVE FEATURES

- General prescriptions: BS 5351, Fire safe BS 6755-API 6 FA- API 607
- Working temperature: from -20°C to +180°C
- Maximum working pressure with actuator: **PN 16** (PN 25 and 40 on request)
- CONNECTIONS with flanges: UNI 2223-2229 AND DIN 2501 BL.1
- FLANGE DRILLING: METRIC
- BLOW-OUT PROOF stem with antistatic device
- For general applications and special versions see technical table of manual valve
- In the below table the part number and the valve code refer to the standard valve **PN 16** and **PN 40** where applicable



SIZE	PART NUMBER	weight in gr.	A	B	C	E	F	G	I	L	PN	ACTUATOR code	VALVE code	Mounting Kit code
DN15	S51AA60400	2320	127	59	74	183	45	M12	65	35	40	SGA0524X00	V515X604	K1GA0104
DN20	S51AA60500	3360	133	70	88	200	50	M12	75	38	40	SGA0634X00	V515X605	K1GA0005
DN25	S51AA60600	4780	132	83	100	228	55	M12	85	43	40	SGA0754X00	V515X606	K1GA0106
DN32	S51AA60700	6900	182	91	108	242	65	M16	100	50	40	SGA0834X00	V515X607	K1GA0107
DN40	S51AA60800	9370	203	100	117	255	70	M16	110	60	40	SGA0924X00	V515X608	K1GA0108
DN50	S51AA60900	13020	222	83	140	285	75	M16	125	70	40	SNA1104X00	V515X609	K1GA0108
DN65	S51AA61000	25120	300	137	160	337	87.5	M16	145	95	16	SNA1274X00	V515X610	K1GA0110
DN65	S52AA61000	25120	300	137	160	337	87.5	M16	145	95	40	SNA1274X00	V886X610	K1GA0110
DN80	S51AA61100	38390	380	172	198	395	95	M16	160	118	40	SNA1604X00	V515X611	K1GA0111
DN100	S51AA61200	51270	380	172	198	426	110	M16	180	140	16	SNA1605X00	V515X612	K1GA0112
DN100	S52AA61200	56880	380	172	198	434	118	M20	190	140	40	SNA1605X00	V886X612	K1GA0112

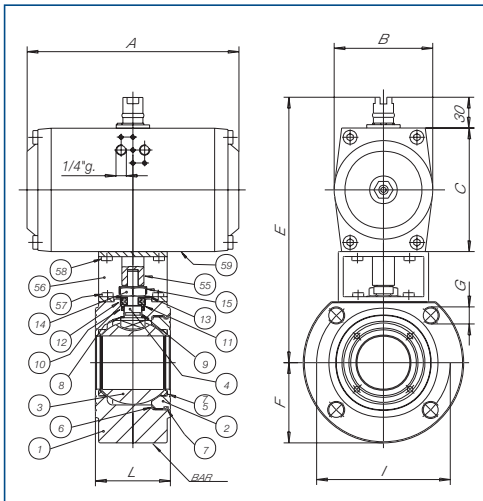

LIST OF VALVE COMPONENTS AND MATERIALS

REF.	PART	QTY	MATERIAL
1	BODY	1	ASTM A105
2	THREADED LOCKING RING	1	ASTM A105
3	BALL	1	AISI 316/AISI 304
4	STEM	1	AISI 304
5	SEAT	2	PTFE
6	SIDE SEALING RING	1	PTFE
7	O-RING	1	NBR
8	UPPER SEALING RING	2	PTFE
9	STEM O-RING	1	VITON
10	UPPER SEALING COUPLE	1	PTFE
11	PACKING GLAND	1	AISI 304
12	WASHER	1	AISI 304
13	BELLEVILLE WASHERS	2	50CrV4
14	STEM RETAINING NUT	1	C.S.
15	FIXING NUT PLATE	1	AISI 304
55	ACTUATOR SHAFT	1	C.S.
56	BRACKET	1	C.S.
57	BRACKET/VALVE SCREW	4	8.8
58	BRACKET/ACTUATOR SCREW	4	8.8
59	ACTUATOR	1	

For accessories see relevant catalogue sheet

MOON OT58

WAFER BALL VALVE - FULL BORE

MAIN STANDARD FEATURES

- CONSTRUCTION: OT58 CW617
- DIAMETER: from DN15 to DN50
- PRESSURES: PN16
- TEMPERATURE LIMITS: from -20°C to +150°C for fluids
from -20°C to +60°C for gas
- CONNECTIONS with flanges: UNI 2223-2229 and DIN 2501 BL.1
- FLANGE DRILLING: METRIC
- BLOW-OUT PROOF stem with antistatic device
- WRAPPING SEATS
- TRIPLE stem-packing with labyrinth effect and automatic adjustment by Belleville washers
- ISO 5211 mounting plate for actuators
- OPERATION device: lever handle



STANDARD PART NUMBERS

Art. T10

standard

SPECIAL EXECUTIONS

- Yellow lever handle for gas
- Drilled ball and unidirectional valve
- On request the valve is available with ATEX certificate
- For further special requests please consult our technical/commercial service

GENERAL APPLICATIONS

Use as an ON-OFF valve for: distribution lines for gas, air, water. Thanks to its reduced face to face dimensions and its intrinsic features it offers wide applications in new projects also as an alternative to the split body valve.

For special utilizations ascertain the compatibility with process features and the corrosion resistance also by the relevant table.

For a line assembly we recommend the use of raised face flanges to UNI 2229 and relevant flat seals.

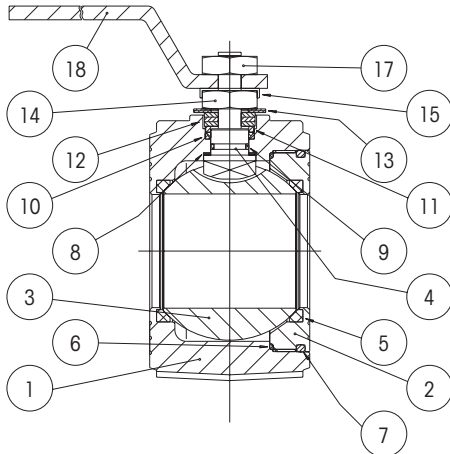

LIST OF COMPONENTS AND MATERIALS

REF.	PART	MATERIAL	DIN MAT.	QTY
1	BODY	OT58		1
2	THREADED LOCKING RING	OT58		1
3	BALL	OT58		1
4	STEM	AISI 304	1.4301	1
5	SEAT	PTFE		2
6	SIDE SEALING RING	PTFE		1
8	UPPER RING	PTFE		2
9	STEM O-RING	VITON		1
10	UPPER SEALING COUPLE	PTFE		1
11	GLAND WASHER	AISI 304	1.4301	1
12	OPERATION STOP	AISI 304	1.4301	3
13	BELLEVILLE WASHERS	50CrV4		2
14	STEM RETAINING NUT	C.S.		1
15	FIXING NUT PLATE	AISI 304	1.4301	1
17	LOCKING NUT	C.S.		1
18	LEVER HANDLE	C.S.		1

MOON OT58

WAFER BALL VALVE - FULL BORE

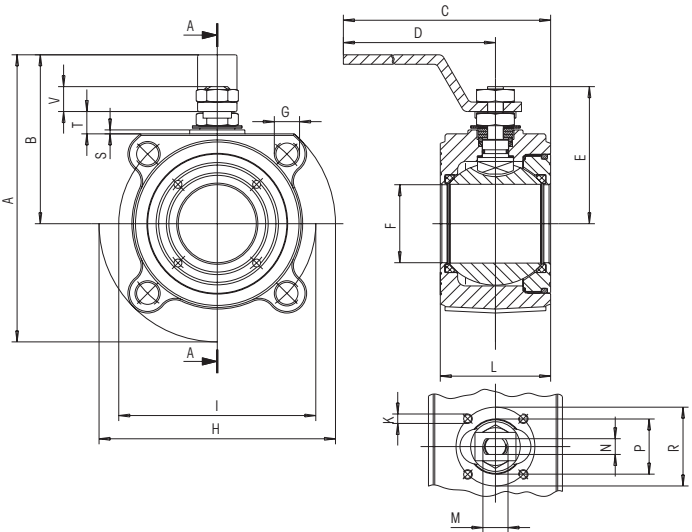

FLANGE DRILLINGS UNI2223-67

SIZE	A	B (PN40)	C (PN16)
DN15	M12	14	0
DN20	M12	16	0
DN25	M12	16	0
DN32	M16	18	0
DN40	M16	18	13
DN50	M16	18	15
DN65	M16	20	15
DN80	M16	24	17
DN100	M16	20	17
DN100	M20	24	0

FLANGE DRILLINGS ANSI 150

SIZE	A	B (PN40)	C (PN16)
DN15	1/2"	13	0
DN20	1/2"	14	0
DN25	1/2"	16	0
DN32	1/2"	17	0
DN40	1/2"	19	0
DN50	5/8"	20	18.4 (17.4)
DN65	5/8"	24	18.4 (20.6)
DN80	5/8"	24	18.4 (22.2)
DN100	5/8"	24	18.4 (22.2)

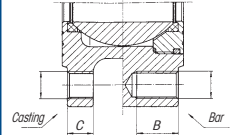

SIZE	A	B	C	D	E	F	G	H	K	I	L	M	N	P	R	S	T	V	N° HOLES	PN	ISO CONN.	WEIGHT IN GR.
DN15	110	65	160	140	48	15	M12	90	M5	65	35	M10	6	25	36	2	8	9	4	16	F03	845
DN20	120	70	160	140	51	20	M12	100	M5	75	38	M10	6	25	36	2	8	9	4	16	F03	1210
DN25	137	82	200	180	62.5	25	M12	110	M5	85	43	M12	8	30	42	2	11.5	11.5	4	16	F04	1715
DN32	150	85	205	180	67	32	M16	130	M5	100	50	M12	8	30	42	2	9.5	11.5	4	16	F04	2785
DN40	172	102	260	230	80	40	M16	140	M6	110	60	M16	10	35	50	2.5	14	16	4	16	F05	3655
DN50	185	110	265	230	87	50	M16	150	M6	125	70	M16	10	35	50	2.5	14	16	4	16	F05	5055

BREAKAWAY TORQUES in Nm

DN size	15	20	25	32	40	50
0	4	7	10	16	25	35
16	4.8	8.5	11.3	19	28	39

PN - bar

The values in Nm may vary as a function of the seals material, temperature and type of medium. For a firm operation of the various types of actuators, in the different working conditions it is necessary to consider a safety factor of 1.5. During operation, with frequent open and close cycles, the operating torque can decrease considerably in comparison with the initial breakaway torque.

PRESSURE/TEMPERATURE DIAGRAM

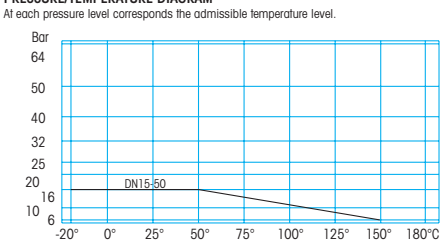

LOSS OF HEAD DIAGRAM/FLOW RATE

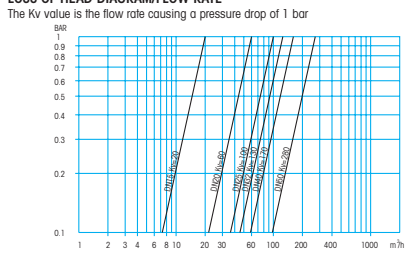

MOON OT58

WAFER BALL VALVE - FULL BORE WITH **DOUBLE ACTING** PNEUMATIC ACTUATOR

ACTUATOR FEATURES

- Rotation angle: 90°
- Standard version for temperature between -20°C and + 90°C
- Supply maximum pressure: 10 bar (8bar for DNA045)
- Nominal pressure: 5,62 bar
- Supply medium: dry filtered compressed air, not necessarily lubricated
- Lubrication: in such a case use a non-detergent or NBR compatible oil

STANDARD VALVE FEATURES

- Working temperature: from -20°C to +150°C for fluids
from -20°C to + 60°C for gas
- Maximum working pressure with actuator: **PN16**
- CONNECTIONS with flanges: UNI 2223-2229 AND DIN 2501 BL.1
- FLANGE DRILLING: METRIC
- BLOW-OUT PROOF stem with antistatic device
- For general applications and special versions see technical table of manual valve
- In the below table the part number and the valve code refer to the standard valve **PN16**



SIZE	Part Number	Weight in gr.	A	B	C	E	F	G	I	L	PN	ACTUATOR code	VALVE code	MOUNTING KIT code
DN15	DT1AA60400	1380	110	53	68	167	45	M12	65	35	16	DNA045AZ00	VT102604	K1GA0004
DN20	DT1AA60500	1760	110	53	68	170	50	M12	75	38	16	DNA045AZ00	VT102605	K1GA0004
DN25	DT1AA60600	2580	127	59	74	202	55	M12	85	43	16	DGA052AX00	VT102606	K1GA0006
DN32	DT1AA60700	4240	133	70	88	222	65	M16	100	50	16	DGA063AX00	VT102607	K1GA0007
DN40	DT1AA60800	6345	132	83	100	238	70	M16	110	60	16	DGA075AX00	VT102608	K1GA0008
DN50	DT1AA60900	6200	182	91	108	253	75	M16	125	70	16	DGA083AX00	VT102609	K1GA0008

For a line assembly we recommend the use of raised face flanges to UNI 2229 and relevant flat seals

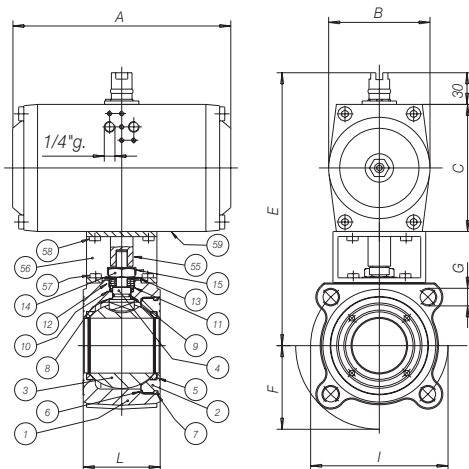

LIST OF VALVE COMPONENTS AND MATERIALS

REF.	PART	Qty	MATERIAL
1	BODY	1	OT58
2	THREADED LOCKING RING	1	OT58
3	BALL	1	OT58
4	STEM	1	AISI 304
5	SEAT	2	PTFE
6	SIDE SEALING RING	1	PTFE
7	O-RING	1	NBR
8	UPPER SEALING RING	2	PTFE
9	STEM O-RING	1	VITON
10	UPPER SEALING COUPLE	1	PTFE
11	GLAND WASHER	1	AISI 304
12	WASHER	1	AISI 304
13	BELLEVILLE WASHERS	2	50CrV4
14	STEM RETAINING NUT	1	ACIER INOX
15	FIXING NUT PLATE	1	AISI 304
55	ACTUATOR SHAFT	1	C.S.
56	BRACKET	1	C.S.
57	BRACKET/VALVE SCREW	4	8.8
58	BRACKET/ACTUATOR SCREW	4	8.8
59	ACTUATOR	1	

For accessories see relevant catalogue sheet

MOON OT58

WAFER BALL VALVE - FULL BORE WITH **SPRING RETURN** PNEUMATIC ACTUATOR

ACTUATOR FEATURES

- Rotation angle: 90°
- Standard version for temperature between -20°C and + 90°C
- Supply maximum pressure: 10 bar (8bar for DNA045)
- Nominal pressure: 5,62 bar
- Supply medium: dry filtered compressed air, not necessarily lubricated
- Lubrication: in such a case use a non-detergent or NBR compatible oil
- STANDARD: SPRING CLOSES/AIR OPENS, clockwise automatic closing

STANDARD VALVE FEATURES

- Working temperature: from -20°C to +150°C for fluids
from -20°C to + 60°C for gas
- Maximum working pressure with actuator: **PN16**
- CONNECTIONS with flanges: UNI 2223-2229 AND DIN 2501 BL.1
- FLANGE DRILLING: METRIC
- BLOW-OUT PROOF stem with antistatic device
- For general applications and special versions see technical table of manual valve
- In the below table the part number and the valve code refer to the standard valve **PN16**



SIZE	Part Number	Weight in gr.	A	B	C	E	F	G	I	L	PN	ACTUATOR code	VALVE code	Mounting Kit code
DN15	ST1AA60400	1820	127	59	74	183	45	M12	65	35	16	SGA0524X00	VT102604	K1GA0104
DN20	ST1AA60500	2760	133	70	88	200	50	M12	75	38	16	SGA0634X00	VT102605	K1GA0005
DN25	ST1AA60600	3990	132	83	100	228	55	M12	85	43	16	SGA0754X00	VT102606	K1GA0106
DN32	ST1AA60700	5690	182	91	108	242	65	M16	100	50	16	SGA0834X00	VT102607	K1GA0107
DN40	ST1AA60800	8075	203	100	117	255	70	M16	110	60	16	SGA0924X00	VT102608	K1GA0108
DN50	ST1AA60900	12030	222	83	140	285	75	M16	125	70	16	SNA1104X00	VT102609	K1GA0108

For a line assembly we recommend the use of raised face flanges to UNI 2229 and relevant flat seals

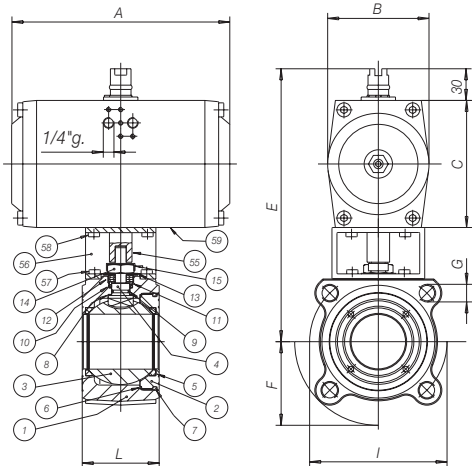

LIST OF VALVE COMPONENTS AND MATERIALS

REF.	PART	Qty	MATERIAL
1	BODY	1	OT58
2	THREADED LOCKING RING	1	OT58
3	BALL	1	OT58
4	STEM	1	AISI 304
5	SEAT	2	PTFE
6	SIDE SEALING RING	1	PTFE
7	O-RING	1	NBR
8	UPPER SEALING RING	2	PTFE
9	STEM O-RING	1	VITON
10	UPPER SEALING COUPLE	1	PTFE
11	GLAND WASHER	1	AISI 304
12	WASHER	1	AISI 304
13	BELLEVILLE WASHERS	2	50CrV4
14	STEM RETAINING NUT	1	ACIER INOX
15	FIXING NUT PLATE	1	AISI 304
55	ACTUATOR SHAFT	1	C.S.
56	BRACKET	1	C.S.
57	BRACKET/VALVE SCREW	4	8.8
58	BRACKET/ACTUATOR SCREW	4	8.8
59	ACTUATOR	1	

For accessories see relevant catalogue sheet

MOON ND AISI 316

WAFER BALL VALVE - FULL BORE WITH CONTAINED BALL

MAIN STANDARD FEATURES

- CONSTRUCTION: AISI 316
- General prescriptions: BS 5351
- Certifications: FIRE SAFE to: BS 6755 - API 6 FA - API 607
DVGW for gas
TÜV for TA Luft
- DIAMETER: from DN15 to DN100
- PRESSURES: PN16/40 from DN15 to DN40 and DN80
PN16 for DN50, DN65 and DN100
- TEMPERATURE LIMITS: from -20°C to +180°C
- CONNECTIONS with flanges: UNI 2223-2229 and DIN 2501 BL.1
- FLANGE DRILLING: METRIC
- BLOW-OUT PROOF stem with antistatic device (from DN40)
- WRAPPING SEATS
- TRIPLE stem-packing with labyrinth effect and automatic adjustment by Belleville washers
- ISO 5211 mounting plate for actuators
- Non wetted parts in stainless steel
- OPERATION device: lever handle



DVGW GAS
APPROVED

STANDARD PART NUMBERS

Art. 2871 DN15÷25

Art. N10 DN32÷100

SPECIAL EXECUTIONS

- 15% GLASS-FILLED PTFE with temperature limits -20°C +195°C
- PTFE+CARBOGRAPHITE with temperature limits -20°C +210°C
- Integral sealing in PTFE from DN15 to DN100
- DN50, DN65 and DN100 PN25/40: metric drilled flanges
From 1/2" to 4" ANSI 150: through drilled flanges
- Reduction gear with manual operation
- Stem extensions: 50mm or 100mm
- Yellow lever handle for gas
- Heating jacket (see MOON CR series)
- Drilled ball and unidirectional valve
- Degreased version
- Antistatic device from DN15 to DN32
- On request the valve is available with ATEX certificate
- For further special requests please consult our technical/commercial service

GENERAL APPLICATIONS

Use as an ON-OFF valve for: chemical products, food, distribution lines for gas, air water. Suitable for vacuum 1.10⁻³ STD CC, steam up to +195°C with PTFE+CARBOGRAPHITE and for industrial installations in general Thanks to its reduced face to face dimensions and its intrinsic features it offers wide applications in new projects also as an alternative to the split body valve.

For special utilizations ascertain the compatibility with process features and the corrosion resistance also by the relevant table.

LIST OF COMPONENTS AND MATERIALS

REF.	PART	MATERIAL	DIN MAT.	QTY
1	BODY	AISI 316	1.4401	1
2	THREADED LOCKING RING	AISI 316	1.4401	1
3	BALL	AISI 316	1.4401	1
4	STEM	AISI 316	1.4401	1
5	SEAT	PTFE		2
6	SIDE SEALING RING	PTFE		1
7	O-RING	NBR		1
8	UPPER RING	PTFE		2
9	STEM O-RING	VITON		1
10	UPPER SEALING COUPLE	PTFE		1
11	PACKING GLAND	AISI 304	1.4301	1
12	OPERATION STOP	AISI 316		1
13	BELLEVILLE WASHERS	500rV4		2
14	STEM RETAINING NUT	S.S.		1
15	FIXING NUT PLATE	AISI 304	1.4301	1
17	LOCKING NUT	S.S.		1
18	LEVER HANDLE	S.S.		1
19	OPERATION STOP SCREW	S.S.		1

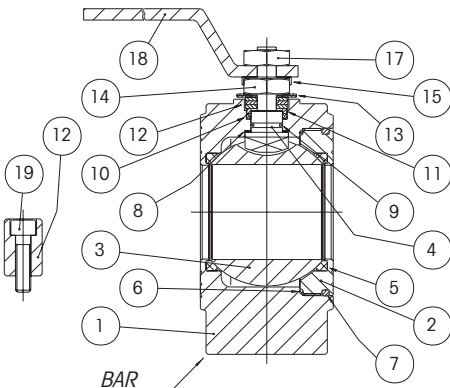

MOON ND AISI 316

WAFER BALL VALVE - FULL BORE WITH CONTAINED BALL

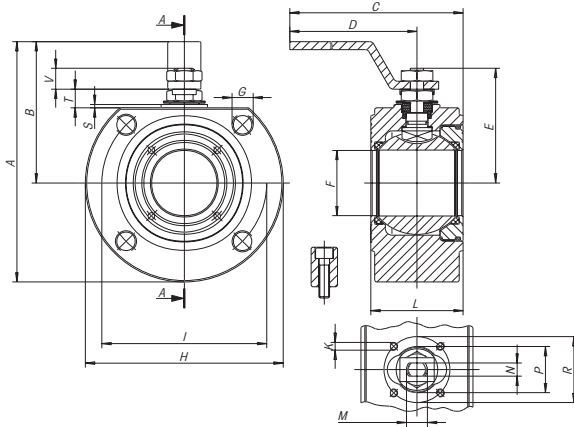

FLANGE DRILLINGS UNI2223-67

SIZE	A	B (PN40)	C (PN16)
DN15	M12	14	0
DN20	M12	16	0
DN25	M12	16	0
DN32	M16	18	0
DN40	M16	18	13
DN50	M16	18	15
DN65	M16	20	15
DN80	M16	24	17
DN100	M16	20	17
DN100	M20	24	0

FLANGE DRILLINGS ANSI 150

SIZE	A	B (PN40)	C (PN16)
DN15	1/2"	13	0
DN20	1/2"	14	0
DN25	1/2"	16	0
DN32	1/2"	17	0
DN40	1/2"	19	0
DN50	5/8"	20	(*)184 (72.4)
DN65	5/8"	24	(*)184 (72.6)
DN80	5/8"	24	(*)184 (72.2)
DN100	5/8"	24	(*)184 (72.2)

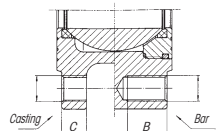

SIZE	A	B	C	D	E	F	G	H	K	I	L	M	N	P	R	S	T	V	N° HOLES	PN	ISO CONN.	WEIGHT IN GR.
DN15	110	65	160	140	48	15	M12	90	M5	65	35	M10	6	25	36	2	8	9	4	40	F03	1345
DN20	120	70	160	140	51	20	M12	100	M5	75	38	M10	6	25	36	2	8	9	4	40	F03	1810
DN25	137	82	200	180	62.5	25	M12	110	M5	85	43	M12	8	30	42	2	11.5	11.5	4	40	F04	2505
DN32	150	85	205	180	67	32	M16	130	M5	100	54	M12	8	30	42	2	9.5	11.5	4	40	F04	4420
DN40	172	102	260	230	80	40	M16	140	M6	110	66	M16	10	35	50	2.5	14	16	4	40	F05	6130
DN50	185	110	265	230	87	50	M16	150	M6	125	83	M16	10	35	50	2.5	14	16	4	16	F05	8555
DN65	225	137.5	400	350	119.5	65	M16	175	M8	145	103	M22	14	55	70	3	18.7	20.8	4	16	F07	15900
DN65	225	137.5	400	350	119.5	65	M16	175	M8	145	103	M22	14	55	70	3	18.7	20.8	8	40	F07	15900
DN80	245	150	410	350	129.5	78	M16	190	M8	160	122	M22	14	55	70	3	18.7	20.8	8	40	F07	20610
DN100	275	165	580	508	148.5	96	M16	220	M10	180	153	M27	16	70	102	3	22.2	25.3	8	16	F10	34230
DN100	291	173	580	508	156.5	96	M20	235	M10	190	153	M27	16	70	102	3	22.2	-	8	40	F10	39500

BREAKAWAY TORQUES in Nm

DN size	15	20	25	32	40	50	65	80	100
0	4	7	10	16	25	35	55	75	150
16	4.8	8.5	11.3	19	28	39	59	84.5	168
25	5.2	9.1	12	20.5	29.5	41.5	62.5	92	180
40	6	10.5	13	22.5	31.5	44	37	99	195

Nm

The values in Nm may vary as a function of the seals material, temperature and type of medium. For a firm operation of the various types of actuators, in the different working conditions it is necessary to consider a safety factor of 1.5. During operation, with frequent open and close cycles, the operating torque can decrease considerably in comparison with the initial breakaway torque.

PRESSURE/TEMPERATURE DIAGRAM

At each pressure level corresponds the admissible temperature level.

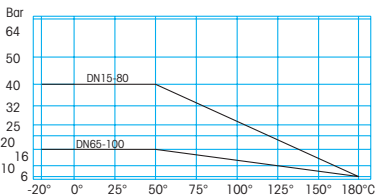

LOSS OF HEAD DIAGRAM/FLOW RATE

The Kv value is the flow rate causing a pressure drop of 1 bar

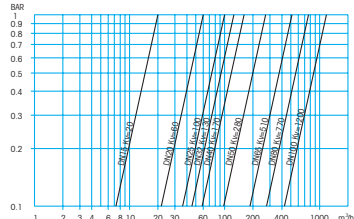

MOON ND AISI 316

WAFER BALL VALVE - FULL BORE WITH **CONTAINED BALL** WITH **DOUBLE ACTING PNEUMATIC ACTUATOR**

ACTUATOR FEATURES

- Rotation angle: 90°
- Standard version for temperature between -20°C and + 90°C
- Supply maximum pressure: 10 bar (8bar for DNA045)
- Nominal pressure: 5,62 bar
- Supply medium: dry filtered compressed air, not necessarily lubricated
- Lubrication: in such a case use a non-detergent or NBR compatible oil

STANDARD VALVE FEATURES

- General prescriptions: BS5351, Fire safe to: BS6755 - API 6 FA - API 607
- Working temperature: from -20°C to +180°C
- Maximum working pressure with actuator: **PN16** (PN25 and 40 on request)
- CONNECTIONS with flanges: UNI 2223-2229 and DIN 2501 BL.1
- FLANGE DRILLING: METRIC
- BLOW-OUT PROOF stem with antistatic device
- For general applications and special versions see technical table of manual valve
- In the below table the part number and the valve code refer to the standard valve **PN16** and PN40 where applicable



SIZE	Part Number	Weight in gr.	A	B	C	E	F	G	I	L	PN	ACTUATOR code	VALVE code	MOUNTING KIT code
DN15	D41AA60400	1880	110	53	68	167	45	M12	65	35	40	DNA045AZ00	V415X604	K1GA0004
DN20	D41AA60500	2360	110	53	68	170	50	M12	75	38	40	DNA045AZ00	V415X605	K1GA0004
DN25	D41AA60600	3370	127	59	74	202	55	M12	85	43	40	DGA052AX00	V415X606	K1GA0006
DN32	D4DAA60700	5875	133	70	88	222	65	M16	100	54	40	DGA063AX00	VN104607	K1GA0007
DN40	D4DAA60800	8230	132	83	100	238	70	M16	110	66	40	DGA075AX00	VN104608	K1GA0008
DN50	D4DAA60900	11255	182	91	108	253	75	M16	125	83	40	DGA083AX00	VN104609	K1GA0008
DN65	D4DAA61000	19615	203	100	117	294	87.5	M16	145	103	16	DGA092AX00	VN102610	K1GA0010
DN65	D4FAA61000	19615	203	100	117	294	87.5	M16	145	103	40	DGA092AX00	VN104610	K1GA0010
DN80	D4DAA61100	25895	222	120	140	327	95	M16	160	122	40	DNA110AX00	VN104611	K1GA0011
DN100	D4DAA61200	43530	294	137	160	378	110	M16	180	153	16	DNA127AX00	VN102612	K1GA0012
DN100	D4FAA61200	49800	294	137	160	386	118	M20	190	153	40	DNA127AX00	VN104612	K1GA0012

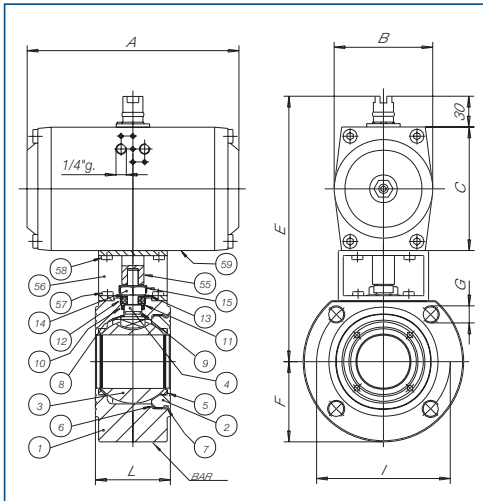

LIST OF VALVE COMPONENTS AND MATERIALS

REF.	PART	Qty	MATERIAL
1	BODY	1	AISI 316/CF8M
2	THREADED LOCKING RING	1	AISI 316
3	BALL	1	AISI 316
4	STEM	1	AISI 316
5	SEAT	2	PTFE
6	SIDE SEALING RING	1	PTFE
7	O-RING	1	NBR
8	UPPER RING	2	PTFE
9	STEM O-RING	1	VITON
10	UPPER SEALING COUPLE	1	PTFE
11	GLAND WASHER	1	AISI 304
12	WASHER	1	AISI 304
13	BELLEVILLE WASHERS	2	50CrV4
14	STEM RETAINING NUT	1	S.S.
15	FIXING NUT PLATE	1	AISI 304
55	ACTUATOR SHAFT	1	C.S.
56	BRACKET	1	C.S.
57	BRACKET/VALVE SCREW	4	8.8
58	BRACKET/ACTUATOR SCREW	4	8.8
59	ACTUATOR	1	

For accessories see relevant catalogue sheet

MOON ND AISI 316

WAFFER BALL VALVE - FULL BORE WITH CONTAINED BALL WITH SPRING RETURN PNEUMATIC ACTUATOR

ACTUATOR FEATURES

- Rotation angle: 90°
- Standard version for temperature between -20°C and +90°C
- Supply maximum pressure: 10 bar (8bar for DNA045)
- Nominal pressure: 5,62 bar
- Supply medium: dry filtered compressed air, not necessarily lubricated
- Lubrication: in such a case use a non-detergent or NBR compatible oil
- STANDARD: SPRING CLOSE/AIR OPENS, clockwise automatic closing

STANDARD VALVE FEATURES

- General prescriptions: BS5351, Fire safe to: BS6755 - API 6 FA - API 607
- Working temperature: from -20°C to +180°C
- Maximum working pressure with actuator: **PN16** (PN25 and 40 on request)
- CONNECTIONS with flanges: UNI 2223-2229 and DIN 2501 BL.1
- FLANGE DRILLING: METRIC
- BLOW-OUT PROOF stem with antistatic device
- For general applications and special versions see technical table of manual valve
- In the below table the part number and the valve code refer to the standard valve **PN16** and PN40 where applicable



SIZE	Part Number	Weight in gr.	A	B	C	E	F	G	I	L	PN	ACTUATOR code	VALVE code	Mounting Kit code
DN15	S41AA60400	2320	127	59	74	183	45	M12	65	35	40	SGA0524X00	V415X604	K1GA0104
DN20	S41AA60500	3360	133	70	88	200	50	M12	75	38	40	SGA0634X00	V415X605	K1GA0005
DN25	S41AA60600	4780	132	83	100	228	55	M12	85	43	40	SGA0754X00	V415X606	K1GA0106
DN32	S4DA60700	7325	182	91	108	242	65	M16	100	54	40	SGA0834X00	VN104607	K1GA0107
DN40	S4DA60800	9960	203	100	117	255	70	M16	110	66	40	SGA0924X00	VN104608	K1GA0108
DN50	S4DA60900	14275	222	83	140	285	75	M16	125	83	40	SNA1104X00	VN104609	K1GA0108
DN65	S4DA61000	26020	300	137	160	337	87.5	M16	145	103	16	SNA1274X00	VN102610	K1GA0110
DN65	S4FAA61000	26020	300	137	160	337	87.5	M16	145	103	40	SNA1274X00	VN104610	K1GA0110
DN80	S4DA61100	39500	380	172	198	395	95	M16	160	122	40	SNA1604X00	VN104611	K1GA0111
DN100	S4DA61200	54000	380	172	198	426	110	M16	180	153	16	SNA1605X00	VN102612	K1GA0112
DN100	S4FAA61200	59380	380	172	198	434	118	M20	190	153	40	SNA1605X00	VN104612	K1GA0112

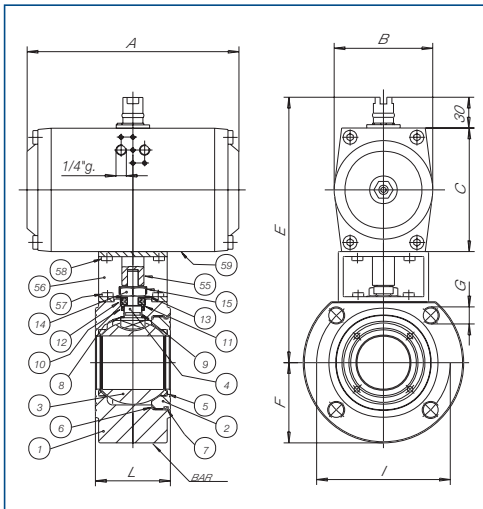

LIST OF VALVE COMPONENTS AND MATERIALS

REF.	PART	Qty	MATERIAL
1	BODY	1	AISI 316/CF8M
2	THREADED LOCKING RING	1	AISI 316
3	BALL	1	AISI 316
4	STEM	1	AISI 316
5	SEAT	2	PTFE
6	SIDE SEALING RING	1	PTFE
7	O-RING	1	NBR
8	UPPER RING	2	PTFE
9	STEM O-RING	1	VITON
10	UPPER SEALING COUPLE	1	PTFE
11	GLAND WASHER	1	AISI 304
12	WASHER	1	AISI 304
13	BELLEVILLE WASHERS	2	50CrV4
14	STEM RETAINING NUT	1	S.S.
15	FIXING NUT PLATE	1	AISI 304
55	ACTUATOR SHAFT	1	C.S.
56	BRACKET	1	C.S.
57	BRACKET/VALVE SCREW	4	8.8
58	BRACKET/ACTUATOR SCREW	4	8.8
59	ACTUATOR	1	

For accessories see relevant catalogue sheet

MOON ND A105

WAFER BALL VALVE - FULL BORE WITH CONTAINED BALL

MAIN STANDARD FEATURES

- CONSTRUCTION: ASTM A 105
- General prescriptions: BS 5351
- CERTIFICATIONS: FIRE SAFE to: BS 6755 - API 6 FA - API 607
DVGW for gas
TÜV for TA Luft
- DIAMETER: from DN15 to DN100
- PRESSURES: PN16/40 from DN15 to DN50 and DN80
PN16 for DN65 and DN100
- TEMPERATURE LIMITS: from -10°C to +180°C
- CONNECTIONS with flanges:
UNI 2223-2229 and DIN 2501 BL.1
- FLANGE DRILLING: METRIC
- BLOW-OUT PROOF stem with antistatic device (from DN40)
- WRAPPING SEATS
- TRIPLE stem-packing with labyrinth effect and automatic adjustment by Belleville washers
- ISO 5211 mounting plate for actuators
- OPERATION devices: lever handle



STANDARD PART NUMBERS

- Art. 2881 DN15÷25
Art. N50 DN32
Art. N70 DN40÷100
with stainless steel ball

SPECIAL EXECUTIONS

- 15% GLASS-FILLED PTFE with temperature limits -10°C + 195°C
- PTFE+CARBOGRAPHITE with temperature limits -20°C + 210°C
- Integral sealing in PTFE from DN15 to DN100
- DN65 and DN100 PN25/40: metric drilled flanges
- From 1/2" to 4" ANSI 150: through drilled flanges
- Reduction gear with manual operation
- Stem extensions; 50mm or 100mm
- Yellow lever handle for gas
- Heating jacket (see MOON CR series)
- Drilled ball and unidirection valve
- Body in LF2 up to -20°C
- Antistatic device from DN15 to DN32
- On request the valve is available with ATEX certificate
- For further special requests please consult our technical/commercial service

GENERAL APPLICATIONS

Use as an ON-OFF valve for: distribution lines for gas, air, water. Suitable for vacuum 1.10-3 STD CC, steam up to +195°C with PTFE+CARBOGRAPHITE and for industrial installations in general. Tanks to its reduced face to face dimensions and its intrinsic features it offers wide applications in new projects also as an alternative to the split body valve.

For special utilizations ascertain the compatibility with process features and the corrosion resistance also by the relevant table.

LIST OF COMPONENTS AND MATERIALS

REF.	PART	MATERIAL	DIN MAT.	QTY
1	BODY	ASTM A105		1
2	THREADED LOCKING RING	ASTM A105		1
3	BALL	See below		1
4	STEM	AISI 304	1.4301	1
5	SEAT	PTFE		2
6	SIDE SEALING RING	PTFE		1
7	O-RING	NBR		1
8	UPPER RING	PTFE		2
9	STEM O-RING	VITON		1
10	UPPER SEALING COUPLE	PTFE		1
11	PACKING GLAND	AISI 304	1.4301	1
12	OPERATION STOP	AISI 304		1
13	BELLEVILLE WASHERS	50CrV4		2
14	STEM RETAINING NUT	C.S.		1
15	FIXING NUT PLATE	AISI 304	1.4301	1
17	LOCKING NUT	C.S.		1
18	LEVER HANDLE	C.S.		1
19	OPERATION STOP SCREW	C.S.		1

Ball: in AISI304 da DN15 to DN32 (Art. 2881 and N50)
in AISI316 da DN40 to DN100 (Art. N70)

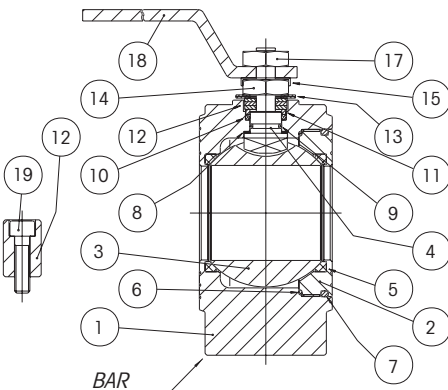

MOON ND A105

WAFER BALL VALVE - FULL BORE WITH CONTAINED BALL

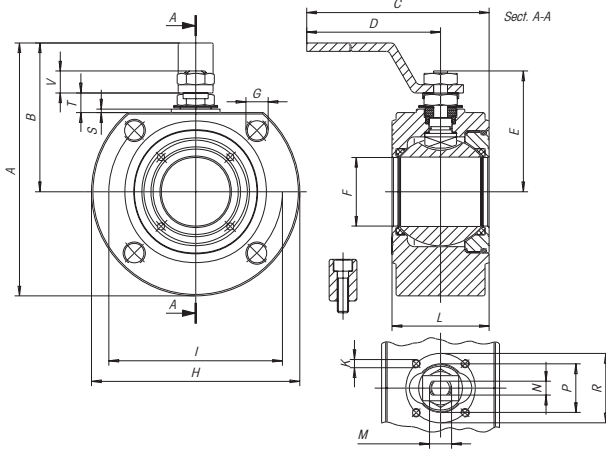

FLANGE DRILLINGS UNI2223-67

SIZE	A	B (PN40)	C (PN16)
DN15	M12	14	0
DN20	M12	16	0
DN25	M12	16	0
DN32	M16	18	0
DN40	M16	18	13
DN50	M16	18	15
DN65	M16	20	15
DN80	M16	24	17
DN100	M16	20	17
DN100	M20	24	0

FLANGE DRILLINGS ANSI 150

SIZE	A	B (PN40)	C (PN16)
DN15	1/2"	13	0
DN20	1/2"	14	0
DN25	1/2"	16	0
DN32	1/2"	17	0
DN40	1/2"	19	0
DN50	5/8"	20	(↑) 16.4 (17.4)
DN65	5/8"	24	(↑) 18.4 (20.6)
DN80	5/8"	24	(↑) 18.4 (22.2)
DN100	5/8"	24	(↑) 18.4 (22.2)

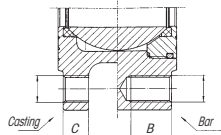

SIZE	A	B	C	D	E	F	G	H	K	I	L	M	N	P	R	S	T	V	N HOLES	PN	ISO	WEIGHT in gr.
DN15	110	65	160	140	48	15	M12	90	M5	65	35	M10	6	25	36	2	8	9	4	40	F03	1345
DN20	120	70	160	140	51	20	M12	100	M5	75	38	M10	6	25	36	2	8	9	4	40	F03	1810
DN25	137	82	200	180	62.5	25	M12	110	M5	85	43	M12	8	30	42	2	11.5	11.5	4	40	F04	2505
DN32	150	85	205	180	67	32	M16	130	M5	100	54	M12	8	30	42	2	9.5	11.5	4	40	F04	4420
DN40	172	102	260	230	80	40	M16	140	M6	110	66	M16	10	35	50	2.5	14	16	4	40	F05	6130
DN50	185	110	265	230	87	50	M16	150	M6	125	83	M16	10	35	50	2.5	14	16	4	40	F05	8555
DN65	225	137.5	400	350	119.5	65	M16	175	M8	145	103	M22	14	55	70	3	18.7	20.8	4	16	F07	15900
DN65	225	137.5	400	350	119.5	65	M16	175	M8	145	103	M22	14	55	70	3	18.7	20.8	8	40	F07	15900
DN80	245	150	410	350	129.5	78	M16	190	M8	160	122	M22	14	55	70	3	18.7	20.8	8	40	F07	20610
DN100	275	165	580	508	148.5	96	M16	220	M10	180	153	M27	16	70	102	3	22.2	25.3	8	16	F10	34230
DN100	291	173	580	508	156.5	96	M20	235	M10	190	153	M27	16	70	102	3	22.2		8	40	F10	39500

BREAKAWAY TORQUES in Nm

DN size	15	20	25	32	40	50	65	80	100
PN - bar	0	4	7	10	16	25	35	55	75
	16	4.8	8.5	11.3	19	28	39	59	84.5
	25	5.2	9.1	12	20.5	29.5	41.5	62.5	92
	40	6	10.5	13	22.5	31.5	44	67	99

Nm

The values in Nm may vary as a function of the seals material, temperature and type of medium. For a firm operation of the various types of actuators, in the different working conditions it is necessary to consider a safety factor of 1.5. During operation, with frequent open and close cycles, the operating torque can decrease considerably in comparison with the initial breakaway torque.

PRESSURE/TEMPERATURE DIAGRAM

At each pressure level corresponds the admissible temperature level.

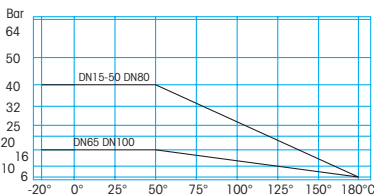

LOSS OF HEAD DIAGRAM/FLOW RATE

The Kv value is the flow rate causing a pressure drop of 1 bar

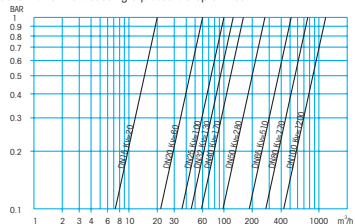

MOON ND A105

WAFER BALL VALVE - FULL BORE WITH CONTAINED BALL WITH **DOUBLE ACTING** PNEUMATIC ACTUATOR

ACTUATOR FEATURES

- Rotation angle: 90°
- Standard version for temperature between -20°C and + 90°C
- Supply maximum pressure: 10 bar (8bar for DNA045)
- Nominal pressure: 5,62 bar
- Supply medium: dry filtered compressed air, not necessarily lubricated
- Lubrication: in such a case use a non-detergent or NBR compatible oil

STANDARD VALVE FEATURES

- General prescriptions: BS 5351, Fire safe BS 6755-API 6 FA- API 607
- Working temperature: from -20°C to +180°C
- Maximum working pressure with actuator: **PN 16** (PN 25 and 40 on request)
- CONNECTIONS with flanges: UNI 2223-2229 AND DIN 2501 BL.1
- FLANGE DRILLING: METRIC
- BLOW-OUT PROOF stem with antistatic device
- For general applications and special versions see technical table of manual valve
- In the below table the part number and the valve code refer to the standard valve **PN 16** and PN 40 where applicable



SIZE	PART NUMBER	weight in gr.	A	B	C	E	F	G	I	L	PN	ACTUATOR code	VALVE code	MOUNTING KIT code
DN15	D51AA60400	1880	110	53	68	167	45	M12	65	35	40	DNA045AZ00	V515X604	K1GA0004
DN20	D51AA60500	2360	110	53	68	170	50	M12	75	38	40	DNA045AZ00	V515X605	K1GA0004
DN25	D51AA60600	3370	127	59	74	202	55	M12	85	43	40	DGA052AX00	V515X606	K1GA0006
DN32	D5DA60700	5875	133	70	88	222	65	M16	100	54	40	DGA063AX00	VN504607	K1GA0007
DN40	D5DA60800	8230	132	83	100	238	70	M16	110	66	40	DGA075AX00	VN704608	K1GA0008
DN50	D5DA60900	11255	182	91	108	253	75	M16	125	83	40	DGA083AX00	VN704609	K1GA0008
DN65	D5DA61000	19615	203	100	117	294	87.5	M16	145	103	16	DGA092AX00	VN704610	K1GA0010
DN65	D5FAA61000	19615	203	100	117	294	87.5	M16	145	103	40	DGA092AX00	VN702611	K1GA0010
DN80	D5DA61100	25895	222	120	140	327	95	M16	160	122	40	DNA110AX00	VN704611	K1GA0011
DN100	D5DA61200	43530	300	137	160	378	110	M16	180	153	16	DNA127AX00	VN702612	K1GA0012
DN100	D5FAA61200	49800	300	137	160	386	118	M20	190	153	40	DNA127AX00	VN704612	K1GA0012

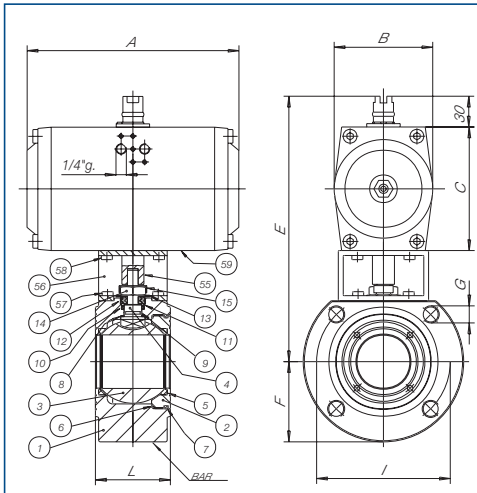

LIST OF VALVE COMPONENTS AND MATERIALS

REF.	PART	QTY	MATERIAL
1	BODY	1	ASTM A105
2	THREADED LOCKING RING	1	ASTM A105
3	BALL	1	AISI 316/AISI 304
4	STEM	1	AISI 304
5	SEAT	2	PTFE
6	SIDE SEALING RING	1	PTFE
7	O-RING	1	NBR
8	UPPER SEALING RING	2	PTFE
9	STEM O-RING	1	VITON
10	UPPER SEALING COUPLE	1	PTFE
11	PACKING GLAND	1	AISI 304
12	WASHER	1	AISI 304
13	BELLEVILLE WASHERS	2	50CrV4
14	STEM RETAINING NUT	1	C.S.
15	FIXING NUT PLATE	1	AISI 304
55	ACTUATOR SHAFT	1	C.S.
56	BRACKET	1	C.S.
57	BRACKET/VALVE SCREW	4	8.8
58	BRACKET/ACTUATOR SCREW	4	8.8
59	ACTUATOR	1	

For accessories see relevant catalogue sheet

MOON ND A105

WAFER BALL VALVE - FULL BORE WITH CONTAINED BALL WITH **SPRING RETURN** PNEUMATIC ACTUATOR

ACTUATOR FEATURES

- Rotation angle: 90°
- Standard version for temperature between -20°C and + 90°C
- Supply maximum pressure: 10 bar
- Nominal pressure: 5,62 bar
- Supply medium: dry filtered compressed air, not necessarily lubricated
- Lubrication: in such a case use a non-detergent or NBR compatible oil
- STANDARD: **SPRING CLOSES/AIR OPENS**, clockwise automatic closing

STANDARD VALVE FEATURES

- General prescriptions: BS 5351, Fire safe BS 6755-API 6 FA- API 607
- Working temperature: from -20°C to +180°C
- Maximum working pressure with actuator: **PN 16** (PN 25 and 40 on request)
- CONNECTIONS with flanges: UNI 2223-2229 AND DIN 2501 BL.1
- FLANGE DRILLING: METRIC
- BLOW-OUT PROOF stem with antistatic device
- For general applications and special versions see technical table of manual valve
- In the below table the part number and the valve code refer to the standard valve **PN 16** and **PN 40** where applicable



SIZE	PART NUMBER	weight in gr.	A	B	C	E	F	G	I	L	PN	ACTUATOR code	VALVE code	MOUNTING KIT code
DN15	S51AA60400	2320	127	59	74	183	45	M12	65	35	40	SGA0524X00	V515X604	K1GA0104
DN20	S51AA60500	3360	133	70	88	200	50	M12	75	38	40	SGA0634X00	V515X605	K1GA0005
DN25	S51AA60600	4780	132	83	100	228	55	M12	85	43	40	SGA0754X00	V515X606	K1GA0106
DN32	S5DA60700	7325	182	91	108	242	65	M16	100	54	40	SGA0834X00	VN504607	K1GA0107
DN40	S5DA60800	9960	203	100	117	255	70	M16	110	66	40	SGA0924X00	VN704608	K1GA0108
DN50	S5DA60900	14275	222	83	140	285	75	M16	125	83	40	SNA1104X00	VN704609	K1GA0108
DN65	S5DA61000	26020	300	137	160	337	87.5	M16	145	103	16	SNA1274X00	VN704610	K1GA0110
DN65	S5FAA61000	26020	300	137	160	337	87.5	M16	145	103	40	SNA1274X00	VN702611	K1GA0110
DN80	S5DA61100	39500	380	172	198	395	95	M16	160	122	40	SNA1604X00	VN704611	K1GA0111
DN100	S5DA61200	54000	380	172	198	426	110	M16	180	153	16	SNA1605X00	VN702612	K1GA0112
DN100	S5FAA61200	59380	380	172	198	434	118	M20	190	153	40	SNA1605X00	VN704612	K1GA0112

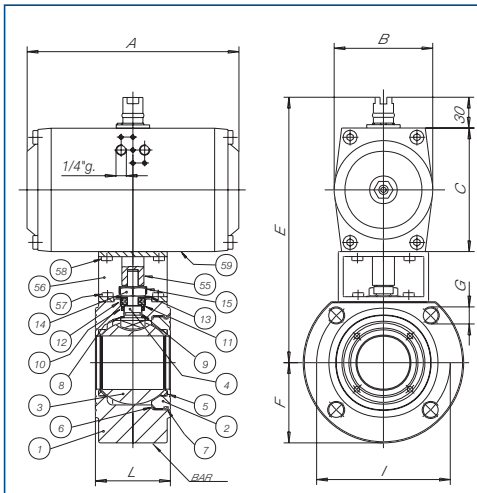

LIST OF VALVE COMPONENTS AND MATERIALS

REF.	PART	QTY	MATERIAL
1	BODY	1	ASTM A105
2	THREADED LOCKING RING	1	ASTM A105
3	BALL	1	AISI 316/AISI 304
4	STEM	1	AISI 304
5	SEAT	2	PTFE
6	SIDE SEALING RING	1	PTFE
7	O-RING	1	NBR
8	UPPER SEALING RING	2	PTFE
9	STEM O-RING	1	VITON
10	UPPER SEALING COUPLE	1	PTFE
11	PACKING GLAND	1	AISI 304
12	WASHER	1	AISI 304
13	BELLEVILLE WASHERS	2	50CrV4
14	STEM RETAINING NUT	1	C.S.
15	FIXING NUT PLATE	1	AISI 304
55	ACTUATOR SHAFT	1	C.S.
56	BRACKET	1	C.S.
57	BRACKET/VALVE SCREW	4	8.8
58	BRACKET/ACTUATOR SCREW	4	8.8
59	ACTUATOR	1	

For accessories see relevant catalogue sheet

MOON PN64 E ANSI 300

WAFER BALL VALVE - FULL BORE

MAIN STANDARD FEATURES

- CONSTRUCTION: AISI 316 and A105
- General prescriptions: BS 5351
- DIAMETER: PN64 from DIN15 to DN50
ANSI 300 from 1/2" to 2"
- PRESSURES: PN64 and ANSI 300
- TEMPERATURE LIMITS: from -20°C to +180°C
- CONNECTIONS with flanges:
UNI 2223-2229 and DIN 2501 BL.1
ANSI 300 RF - ANSI B16.5
- FLANGE DRILLING: PN64 METRIC
ANSI 300 through drilled
- BLOW-OUT PROOF stem with antistatic device (from DN40)
- WRAPPING SEATS
- TRIPLE stem-packing with labyrinth effect and automatic adjustment by Belleville washers
- ISO 5211 mounting plate for actuators
- NON-WETTED parts in stainless steel
- OPERATION devices: lever handle



STANDARD PART NUMBERS

Art. N105 PN64 AISI316	Art. N505 PN64 A105 up to DN32	Art. N705 PN64 A105 beyond DN32
Art. N10B ANSI 300 AISI316	Art. N50B ANSI 300 A105 up to DN32	Art. N70B ANSI 300 A105 beyond DN 32

SPECIAL EXECUTIONS

- 15% GLASS-FILLED PTFE with temperature limits -20°C + 195°C
- PTFE+CARBOGRAPHITE with temperature limits -20°C + 210°C
- Integral sealing in PTFE from DN15 to DN100
- Flange drilling: ANSI 300 METRIC or WHITWORTH (to be specified)
- Reduction gear with manual operation
- Stem extensions; 50mm or 100mm
- Yellow lever handle for gas
- Heating jacket (see MOON CR series)
- Drilled ball and unidirection valve
- Degreased version
- Antistatic device from DN15 to DN32
- On request the valve is available with ATEX certificate
- For further special requests please consult our technical/commercial service

GENERAL APPLICATIONS

Use as an ON-OFF valve for: chemical products, food plants, distribution lines for gas, air, water. Suitable for vacuum 1-10⁻³ STD CC, steam up to +195°C with PTFE+CARBOGRAPHITE and for industrial installations in general.

Tanks to its reduced face to face dimensions and its intrinsic features it offers wide applications in new projects also as an alternative to the split body valve.

For special utilizations ascertain the compatibility with process features and the corrosion resistance also by the relevant table.

LIST OF COMPONENTS AND MATERIALS

REF.	PART	MATERIAL AISI 316 Vers.	DIN MAT. A 105 Vers.	QTY
1	BODY	AISI 316	ASTM A105	1
2	THREADED LOCKING RING	AISI 316	ASTM A105	1
3	BALL	AISI 316	See below	1
4	STEM	AISI 316	AISI 304	1
5	SEAT	PTFE	PTFE	2
6	SIDE SEALING RING	PTFE	PTFE	1
7	O-RING	NBR	NBR	1
8	UPPER RING	PTFE	PTFE	2
9	STEM O-RING	VITON	VITON	1
10	UPPER SEALING COUPLE	PTFE	PTFE	1
11	GLAND WASHER	AISI 304	AISI 304	1
12	OPERATION STOP	AISI 304	AISI 304	1-3
13	BELLEVILLE WASHERS	AISI 301	50CrV4	2
14	STEM RETAINING NUT	AISI 304	C.S.	1
15	FIXING NUT PLATE	AISI 304	AISI 304	1
17	LOCKING NUT	AISI 304	C.S.	1
18	LEVER HANDLE	AISI 304	C.S.	1

Ball for A105 version: AISI316 up to DN32
 AISI304 beyond DN32

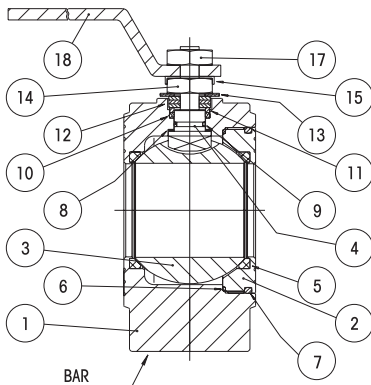

MOON PN64 E ANSI 300

WAFER BALL VALVE - FULL BORE

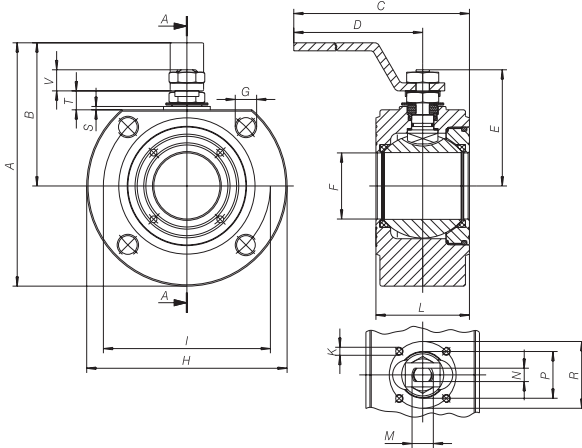

FLANGE DRILLINGS UNI2223-67

SIZE	A	B (PN40)	C (PN16)
DN15	M12	14	0
DN20	M12	16	0
DN25	M12	16	0
DN32	M16	18	0
DN40	M16	18	13
DN50	M16	18	15
DN65	M16	20	15
DN80	M16	24	17
DN100	M16	20	17
DN100	M20	24	0

FLANGE DRILLINGS ANSI 150

SIZE	A	B (PN40)	C (PN16)
DN15	1/2"	13	0
DN20	1/2"	14	0
DN25	1/2"	16	0
DN32	1/2"	17	0
DN40	1/2"	19	0
DN50	5/8"	20	(*) 164 (174)
DN65	5/8"	24	(*) 164 (206)
DN80	5/8"	24	(*) 164 (222)
DN100	5/8"	24	(*) 164 (222)

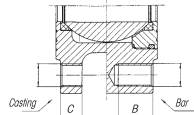

	SIZE	A	B	C	D	E	F	G	H	K	I	L	M	N	P	R	S	T	V	N. HOLES	ISO conn.	Weight in g/lb
PN64	DN15	119	66	161	140	48	15	M12	105	M5	75	42	M10	6	25	36	2	8	9	4	F03	2310
	DN20	138	73	163	140	55.5	20	M16	130	M5	90	46	M10	6	25	36	2	8	9	4	F03	3660
	DN25	160	90	205	180	70.5	25	M16	140	M5	100	50	M12	8	30	42	2	11.5	11.5	4	F04	4750
	DN32	173	95	207	180	75	32	M20	155	M5	110	54	M12	8	30	42	2	9.5	11.5	4	F04	6050
	DN40	194	109	263	230	87.5	40	M20	170	M6	125	66	M16	10	35	50	2.5	14	16	4	F05	8950
DN50	206	116	272	230	94.5	50	M20	180	M6	135	83	M16	10	35	50	2.5	14	16	4	F05	12620	
ANSI 300	1/2"	114	66	161	140	48	15	1/2"	95	M5	67	42	M10	6	25	36	2	8	9	4	F03	2100
	3/4"	130	73	163	140	55.5	20	5/8"	114	M5	82.5	46	M10	6	25	36	2	8	9	4	F03	2900
	1"	152	90	205	180	70.5	25	5/8"	124	M5	88.9	50	M12	8	30	42	2	11.5	11.5	4	F04	3670
	1" 1/4	162	95	207	180	75	32	5/8"	133	M5	99	54	M12	8	30	42	2	9.5	11.5	4	F04	5200
	1" 1/2	187	109	263	230	87.5	40	3/4"	156	M6	114	66	M16	10	35	50	2.5	14	16	4	F05	8210
2"	198.5	116	272	230	94.5	50	5/8"	165	M6	127	83	M16	10	35	50	2.5	14	16	8	F05	11570	

BREAKAWAY TORQUES in Nm

PN - Bar	DN size	15	20	25	32	40	50
		1/2"	3/4"	1"	1 1/4"	1 1/2"	2"
PN64	0	4	7	10	16	25	35
	7	12	16	26.5	37	51	
ANSI 300	6.5	11	14	24	34	47	

Nm

The values in Nm may vary as a function of the seats material, temperature and type of medium. For a firm operation of the various types of actuators, in the different working conditions it is necessary to consider a safety factor of 1.5. During operation, with frequent open and close cycles, the operating torque can decrease considerably in comparison with the initial breakaway torque.

PRESSURE/TEMPERATURE DIAGRAM

At each pressure level corresponds the admissible temperature level.

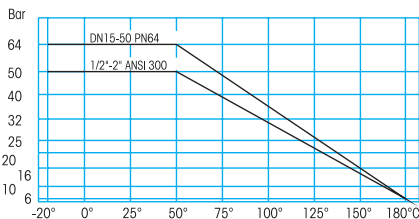

LOSS OF HEAD DIAGRAM/FLOW RATE

The Kv value is the flow rate causing a pressure drop of 1 bar

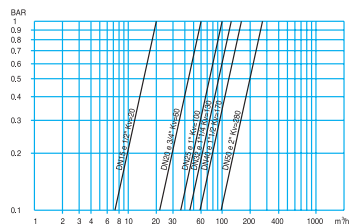

MOON CR

WAFER BALL VALVE — FULL BORE

MAIN STANDARD FEATURES

- CONSTRUCTION:
- wafer ball valve both standard and ND
MOON type in ASTM A 105
MOON in AISI 304 and
MOON in AISI 316 with
heating jacket in carbon steel and flanges PN 16 or gas
parallel threaded ends
- For construction features please refer to relevant technical tables



STANDARD PART NUMBERS

valve	ASTM A105	AISI 304	AISI 316
Moon Standard	Art. L60/L70	Art. L40	Art. L20
Moon ND	Art. P60/P70	Art. P40	Art. P20

SPECIAL EXECUTIONS

- Heating jackets in stainless steel AISI 304
- End connections NPT to ANSI B 1.20.1 (taper threads)
- On request the valve is available with ATEX certificate
- For further special requests please consult our technical/commercial service

GENERAL APPLICATIONS

Use as an ON-OFF valve for: applications requiring the constant maintenance of the process fluid within the valve by means of hot water, oil or other medium circulating inside the jacket applied directly on the outside valve body.

For special utilizations ascertain the compatibility with process features and the corrosion resistance also by the relevant table.

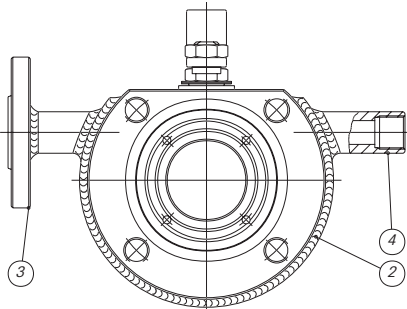

LIST OF COMPONENTS AND MATERIALS

REF.	PART.	MATERIAL	MATERIAL	MATERIAL	QTY
1	VALVE CONSTRUCTION	ASTM A105	AISI 304	AISI 316	1
2	JACKET	C.S.	C.S.	C.S.	1
3	FLANGES	ASTM A105	ASTM A105	ASTM A105	2
4	THREADED END CONNECTIONS	ASTM A105	ASTM A105	ASTM A105	2

MOON CR

WAFER BALL VALVE — FULL BORE

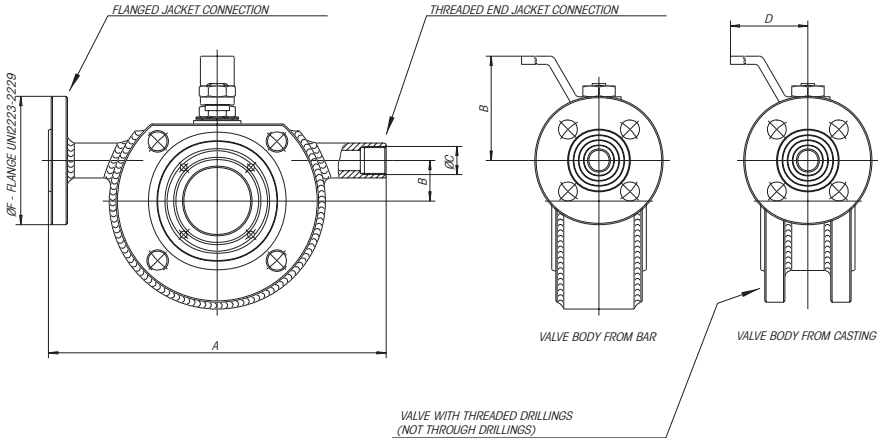

DN	15	20	25	32	40	50	65	80	100
A	160	160	190	210	230	250	270	300	340
B	0	0	0	25	30	40	45	50	70
ØC	G. 1/2"	G. 1/2"	G. 1/2"	G. 1/2"	G. 1/2"	G. 1/2"	G. 1/2"	G. 1/2"	G. 1"
D	140	140	180	180	230	230	350	350	508
E	65	70	82	85	102	110	137.5	150	165
ØF	DN15	DN15	DN15	DN15	DN15	DN15	DN15	DN15	DN25

BREAKAWAY TORQUES in Nm

DN size	15	20	25	32	40	50	65	80	100
0	4	7	10	16	25	35	55	75	150
16	4.8	8.5	11.3	19	28	39	59	84.5	168
25	5.2	9.1	12	20.5	29.5	41.5	62.5	92	180
40	6	10.5	13	22.5	31.5	44	67	99	195

Nm

The values in Nm may vary as a function of the seals material, temperature and type of medium. For a firm operation of the various types of actuators, in the different working conditions it is necessary to consider a safety factor of 1.5. During operation, with frequent open and close cycles, the operating torque can decrease considerably in comparison with the initial breakaway torque.

PRESSURE/TEMPERATURE DIAGRAM

SEE TABLES OF THE
INDIVIDUAL CONSTRUCTIONS

LOSS OF HEAD DIAGRAM/FLOW RATE

The Kv value is the flow rate causing a pressure drop of 1 bar

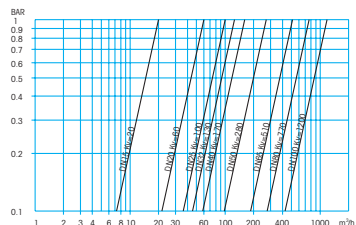

MOON 3W

WAFER BALL VALVE - 3-WAY, "L" OR "T" BORED, REDUCED BORE

MAIN STANDARD FEATURES

- CONSTRUCTION: AISI 316 and ASTM A105
- General prescriptions: BS 5351
- DIAMETER: from DN15 to DN100
- PRESSURES: PN16/40 from DN15 to DN50 and DN80
PN16 for DN65 and DN100
- TEMPERATURE LIMITS: from -20°C to +180°C
- CONNECTIONS with flanges: UNI 2223-2229 and DIN 2501 BL.1
- FLANGE DRILLING: METRIC
- BLOW-OUT PROOF stem with antistatic device (from DN40)
- WRAPPING SIDE SEALING composed of 2 seats
- TRIPLE stem-packing with labyrinth effect and automatic adjustment by Belleville washers
- ISO 5211 mounting plate for actuators
- OPERATION device: lever handle



STANDARD PART NUMBERS

Art. NA02 A 316-PN16,L ball	Art. NF02 A 316-PN16,T ball	Art. NC02 A 105-PN16,L ball	Art. NH02 A 105-PN16,T ball
Art. NA04 A 316-PN40,L ball	Art. NF04 A 316-PN40,T ball	Art. NC04 A 105-PN40,L ball	Art. NH04 A 105-PN40,T ball

SPECIAL EXECUTIONS

- 15% GLASS-FILLED PTFE with temperature limits -20°C +195°C
- PTFE + CARBOGRAPHITE with temperature limits -20°C +210°C
- DN65 and DN100 PN25/40: metric flange drilling
- VALVE with pneumatic actuator
- Reduction gear with manual operation
- Stem extensions: 50mm or 100mm
- Antistatic device from DN15 to DN32
- On request the valve is available with ATEX certificate
- For further special requests please consult our technical/commercial service

GENERAL APPLICATIONS

Use as an ON-OFF valve for deviation or mixing of fluids and gases in general installation.

For special utilizations ascertain the compatibility with process features and the corrosion resistance also by the relevant table.

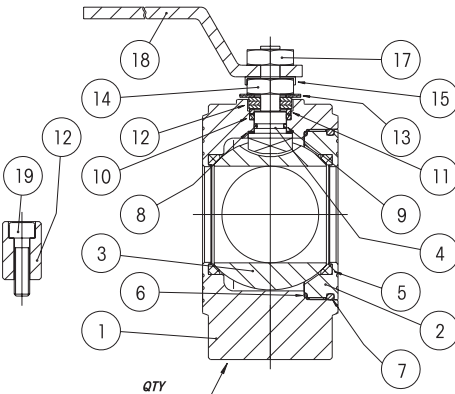

LIST OF COMPONENTS AND MATERIALS

REF.	PART	MATERIAL AISI 316 Valves	MATERIAL A 105 Valves	QTY
1	BODY	AISI 316	ASTM A105	1
2	THREADED LOCKING RING	AISI 316	ASTM A105	1
3	BALL	AISI 316	AISI 316	1
4	STEM	AISI 316	AISI 304	1
5	SEAT	PTFE	PTFE	2
6	SIDE SEALING RING	PTFE	PTFE	1
7	O-RING	NBR	NBR	1
8	UPPER RING	PTFE	PTFE	2
9	STEM O-RING	VITON	VITON	1
10	UPPER SEALING COUPLE	PTFE	PTFE	1
11	GLAND WASHER	AISI 304	AISI 304	1
12	OPERATION STOP	AISI 304	AISI 304	1
13	BELLEVILLE WASHERS	50CrV4	50CrV4	2
14	STEM RETAINING NUT	ACIER INOX	IDEM	1
15	FIXING NUT PLATE	AISI 304	AISI 304	1
17	LOCKING NUT	ACIER INOX	IDEM	1
18	LEVER HANDLE	ACIER INOX	IDEM	1
19	OPERATION STOP SCREW	ACIER INOX	IDEM	1

MOON 3W

WAFER BALL VALVE - 3-WAY, "L" OR "T" BORED, REDUCED BORE

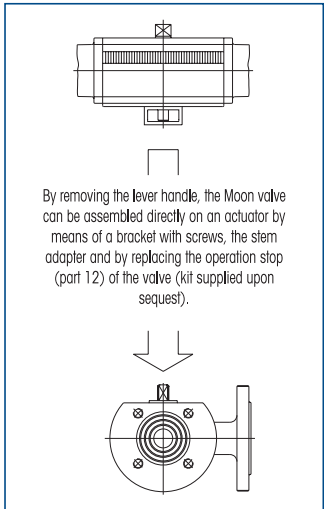
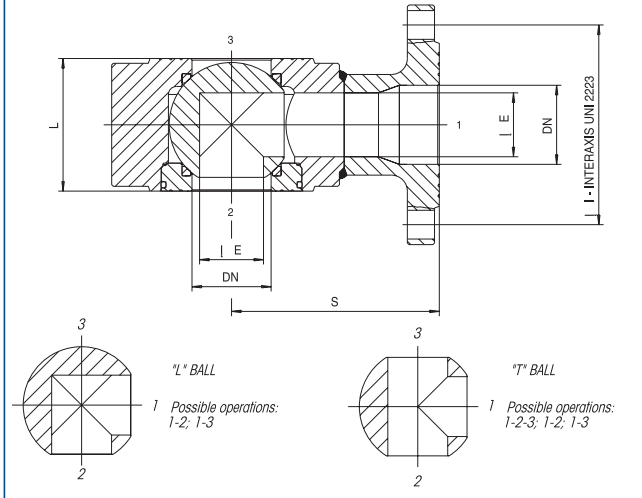

SIZE	øE	øI	L	S	N° HOLES	PN	ISO conn	weight in gr°.
DN15	10	65	35	85	4	40	F03	2140
DN20	15	75	38	90	4	40	F03	2892
DN25	20	85	43	90	4	40	F04	3690
DN32	25	100	54	105	4	40	F04	6125
DN40	32	110	66	120	4	40	F05	8085
DN50	40	125	83	130	4	40	F05	11180
DN65	50	145	103	150	4	16	F07	19470
DN65	50	145	103	150	8	40	F07	19470
DN80	65	160	122	175	8	40	F07	25080
DN100	78	180	153	185	8	16	F10	38565
DN100	78	190	153	195	8	40	F10	45315

For the missing dimensions please refer to the tables concerning MOON ND.

BREAKAWAY TORQUES in Nm

DIN size	15	20	25	32	40	50	65	80	100
0	4	7	10	16	25	35	55	75	150
16	4.8	8.5	11.3	19	28	39	59	84.5	168
25	5.2	9.1	12	20.5	29.5	41.5	62.5	92	180
40	6	10.5	13	22.5	31.5	44	67	99	195

Nm

The values in Nm may vary as a function of the seats material, temperature and type of medium.
For a firm operation of the various types of actuators, in the different working conditions it is necessary to consider a safety factor of 1.5. During operation, with frequent open and close cycles, the operating torque can decrease considerably in comparison with the initial breakaway torque.

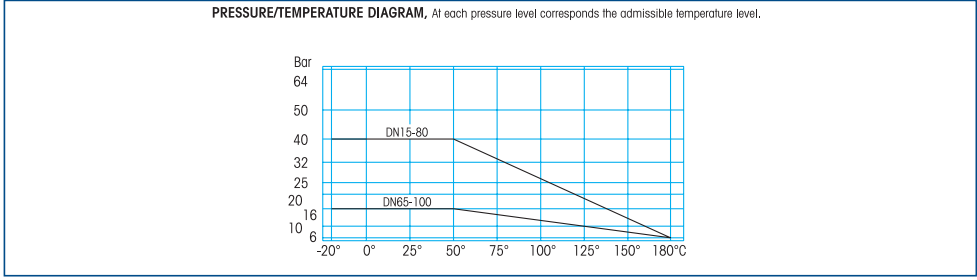

SELENE AISI 316

WAFER SPLIT BODY BALL VALVE - FULL BORE

MAIN STANDARD FEATURES

- CONSTRUCTION: AISI 316
- General prescriptions: BS 5351
- Certifications to FIRE SAFE to: BS 6755 - API 6 FA - API 607 up to DN100
STÜV for TA Luft up to DN100
- DIAMETER: from DN 50 to DN 200
- PRESSURES: PN 16/40 from DN 50 to DN 100
PN 16 DN 125, 150, 200
- TEMPERATURE LIMITS: from -20°C to +180°C
- CONNECTIONS with flanges: UNI 2223-2229 and DIN 2501 BL.1
- FLANGE DRILLING: METRIC
- BLOW-OUT PROOF stem with antistatic device
- WRAPPING SEATS
- ISO 5211 mounting plate for actuators
- OPERATION device: lever handle
- BOLTED flange for ball retaining
- With contained ball

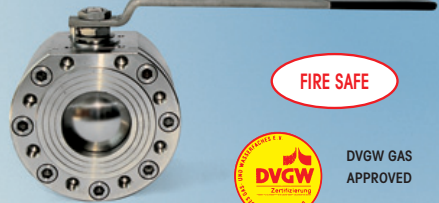

STANDARD PART NUMBERS

Art. 2901

PN16

Art. 2902

PN40

SPECIAL EXECUTIONS

- 15% GLASS-FILLED PTFE with temperature limits -20°C + 195°C
- PTFE+CARBOGRAPHITE with temperature limits -20°C + 210°C
- Integral seats in PTFE up to DN100
- DN 125 to DN 200 PN 25/40
- Reduction gear with manual operation
- Stem extensions: 50 mm or 100 mm up to DN 100
- Yellow lever handle for gas
- Degreased version
- For further special requests please consult our technical/commercial service

GENERAL APPLICATIONS

Use as an ON-OFF valve for: installations for gas, water, air distribution. Suitable for vacuum 1.10⁻³ STD CC, steam up to +195°C with PTFE+CARBOGRAPHITE and for industrial plants in general. Thanks to its reduced face to face dimensions and its intrinsic features it offers wide applications in new projects also as an alternative to the standard split body valve. For special utilizations ascertain the compatibility with process features and the corrosion resistance also by the relevant table.

LIST OF COMPONENTS AND MATERIALS

REF.	PART	MATERIAL	DIN MAT.	QTY
1	BODY	AISI 316	1.4401	1
2	FLANGE	AISI 316	1.4401	1
3	BALL	AISI 316	1.4401	1
4	STEM	AISI 316	1.4401	1
5	SEAT	PTFE		2
6	SIDE SEALING RING	PTFE		1
8	UPPER RING	PTFE		3
9	STEM O-RING	VITON		1
10	UPPER SEALING COUPLE	PTFE		2
11	PACKING GLAND	AISI 304	1.4301	2
12	OPERATION STOP	AISI 304	1.4301	1
13	BELLEVILLE WASHERS	AISI 301	1.4310	2
14	STEM RETAINING NUT	AISI 304	1.4301	1
15	FIXING NUT PLATE	AISI 304	1.4301	1
17	LOCKING NUT	AISI 304	1.4301	1
18	LEVER HANDLE	AISI 304	1.4301	1
19	OPERATION STOP SCREW	AISI 304	1.4301	1
27	FLANGE LOCKING SCREW	AISI 304	1.4301	1
30	SIDE SEALING RING	GRAFITO PURO		1
31	V SHAPED CHEVRON TYPE	PTFE+GRAFITO		1
32	UPPER RING	PTFE		1

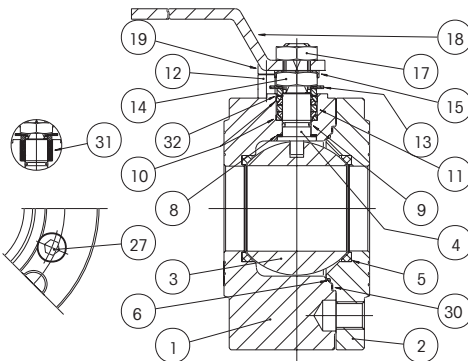

SELENE AISI 316

WAFER SPLIT BODY BALL VALVE - FULL BORE

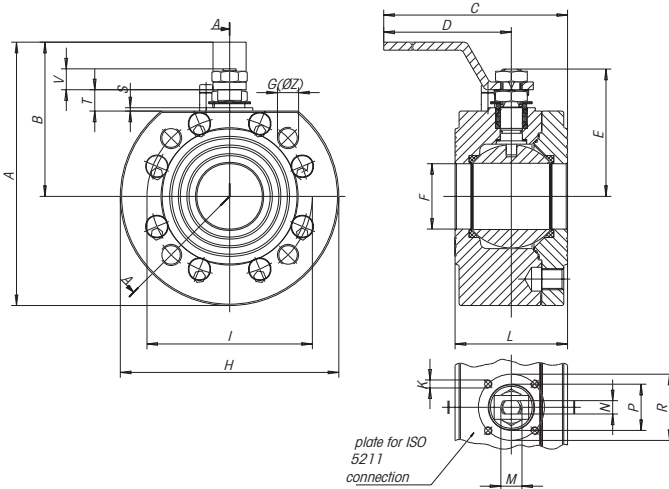

FLANGE DRILLINGS UNI2223-67

SIZE	A	B
DN65	M16	20
DN80	M16	24
DN100	M16	20
DN100	M20	24
DN125	M16	22
DN150	M20	22
DN200	M20	24

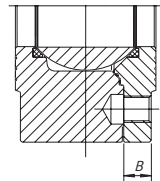

SIZE	A	B	C	D	E	F	G	H	K	I	L	M	N	P	R	S	T	V	N. Holes	PN	ISO	Weight in gr.
DN40	183	108	273	230	87	40	M16	150	M6	110	76	M16	10	-	50	-	10	14	4	40	F05	8750
DN50	199	117	273	230	94.5	49.5	M16	165	M6	125	85	M16	10	35	50	2.5	16	14	4	40	F05	11000
DN65	232	139	372	320	119.5	65	M16	185	M8	145	103	M22	14	55	70	3	19	20.5	8	40	F07	17500
DN65	232	139	372	320	119.5	65	M16	185	M8	145	103	M22	14	55	70	3	19	20.5	8	40	F07	17300
DN80	249	149	381	320	129.5	78	M16	200	M8	160	122	M22	14	55	70	3	19	20.5	8	40	F07	22800
DN100	277	167	448	370	148.5	96	M16	220	M10	180	155	M27	16	70	102	3	22.2	25.3	8	16	F10	34500
DN100	284	167	448	370	148.5	96	M20	235	M10	190	155	M27	16	70	102	3	22.2	25.3	8	40	F10	39000
DN125	309	181	455	370	166.5	118	M16	255	M10	210	170*	M27	16	70	102	3	22.2	25.3	8	16	F10	51220
DN150	388	241	500	395	197.5	144	M20	259	M12	240	210*	M42	26	-	125	-	4	29	8	16	F12	80960
DN200	458	276	829	674	232.5	192	M20	365	M12	295	310*	M42	26	-	125	-	4	29	12	16	F12	177060

* from 2005 DN125 : L 185 DN150 : L 235 DN200 : L 315

BREAKAWAY TORQUES in Nm

DN size	50	65	80	100	125	150	200
0	35	55	75	150	240	310	600
16	39	59	84.5	168	300	400	800
25	41.5	62.5	92	180			
40	44	67	99	195			

Nm

The values in Nm may vary as a function of the seals material, temperature and type of medium. For a firm operation of the various types of actuators, in the different working conditions it is necessary to consider a safety factor of 1.5. During operation, with frequent open and close cycles, the operating torque can decrease considerably in comparison with the initial breakaway torque.

PRESSURE/TEMPERATURE DIAGRAM

At each pressure level corresponds the admissible temperature level.

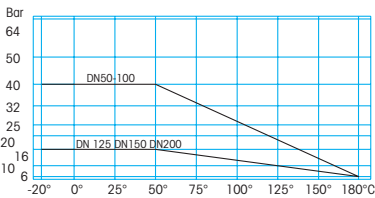

LOSS OF HEAD DIAGRAM/FLOW RATE

The Kv value is the flow rate causing a pressure drop of 1 bar

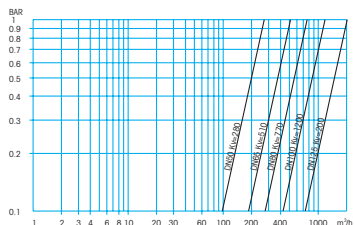

SELENE AISI 316

WAFER SPLIT BODY BALL VALVE - FULL BORE WITH **DOUBLE ACTING** PNEUMATIC ACTUATOR

ACTUATOR FEATURES

- Rotation angle: 90°
- Standard version for temperature between -20°C and + 90°C
- Supply maximum pressure: 10 bar (8bar for DNA045)
- Nominal pressure: 5,62 bar
- Supply medium: dry filtered compressed air, not necessarily lubricated
- Lubrication: in such a case use a non-detergent or NBR compatible oil

STANDARD VALVE FEATURES

- General prescriptions: BS 5351, Fire safe to: BS 6755-API 6 FA- API 607
- Working temperature: from -20°C to +180°C
- Maximum working pressure with actuator: **PN 16** (PN 25 and 40 on request)
- CONNECTIONS with flanges: UNI 2223-2229 AND DIN 2501 BL.1
- FLANGE DRILLING: METRIC
- BLOW-OUT PROOF stem with antistatic device
- For general applications and special versions see technical table of manual valve
- In the below table the part number and the valve code refer to the standard valve **PN 16** and **PN 40** where applicable



SIZE	PART NUMBER	weight in gr.	A	B	C	E	F	G	I	L	PN	ACTUATOR code	VALVE code	MOUNTING KIT code
DN50	D91AA60900	13700	182	91	108	260.5	82.5	M16	125	85	40	DGA083AX00	V901X609	K1GA0008
DN65	D91AA61000	21215	203	100	117	294	92.5	M16	145	103	16	DGA092AX00	V901X610	K1GA0010
DN65	D92AA61000	21015	203	100	117	294	92.5	M16	145	103	40	DGA092AX00	V902X610	K1GA0010
DN80	D91AA61100	28085	222	120	140	327	100	M16	160	122	40	DNA110AX00	V901X611	K1GA0011
DN100	D91AA61200	43800	300	137	160	382	110	M16	180	155	16	DNA127AX00	V901X612	K1GA0012
DN100	D92AA61200	48300	300	137	160	382	117.5	M20	190	155	40	DNA127AX00	V902X612	K1GA0012
DN125	D91AA61300	77000	380	172	198	430	128	M16	210	170*	16	DNA160AX00	V901X613	K1GA0013
DN150	D91AA61400	114000	450	224	255	542	148	M20	240	210*	16	DNA160AX00	V901X614	K1GA0014
DN200	D91AA61500	224000	450	224	255	564	183	M20	295	310*	16	DNA210AX00	V901X615	K1GA0015

* from 2005 DN125 : L 185 DN150 : L 235 DN200 : L 315

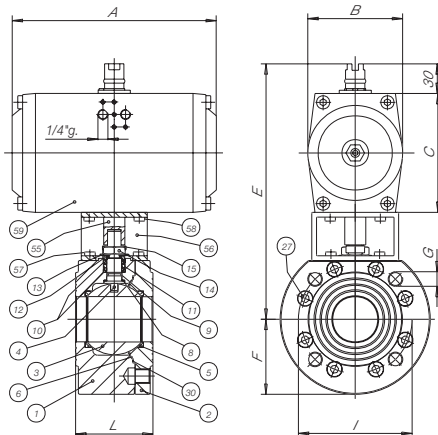

LIST OF VALVE COMPONENTS AND MATERIALS

REF.	PART	QTY	MATERIAL
1	BODY	1	AISI 316/CF8M
2	FLANGE	1	AISI 316
3	BALL	1	AISI 316
4	STEM	1	AISI 316
5	SEAT	2	PTFE
6	SIDE SEALING RING	1	PTFE
8	UPPER RING	3	PTFE
9	STEM O-RING	1	VITON
10	UPPER SEALING COUPLE	1	PTFE
11	PACKING GLAND	1	AISI 304
12	WASHER	1	AISI 304
13	BELLEVILLE WASHERS	2	AISI 301
14	STEM RETAINING NUT	1	AISI 304
15	FIXING NUT PLATE	1	AISI 304
27	FLANGE LOCKING SCREW	8	AISI 304
30	SIDE SEALING RING	1	GRAPHITE
55	ACTUATOR SHAFT	1	C.S.
56	BRACKET	1	C.S.
57	BRACKET/VALVE SCREW	4	8.8
58	BRACKET/ACTUATOR SCREW	4	8.8
59	ACTUATOR	1	

For accessories see relevant catalogue sheet

SELENE AISI 316

WAFER SPLIT BODY BALL VALVE - FULL BORE WITH **SPRING RETURN PNEUMATIC ACTUATOR**

ACTUATOR FEATURES

- Rotation angle: 90°
- Standard version for temperature between -20°C and + 90°C
- Supply maximum pressure: 10 bar
- Nominal pressure: 5,62 bar
- Supply medium: dry filtered compressed air, not necessarily lubricated
- Lubrication: in such a case use a non-detergent or NBR compatible oil
- STANDARD: **SPRING CLOSES/AIR OPENS**, clockwise automatic closing

STANDARD VALVE FEATURES

- General prescriptions: BS 5351, Fire safe BS 6755-API 6 FA- API 607
- Working temperature: from -20°C to +180°C
- Maximum working pressure with actuator: **PN 16** (PN 25 and 40 on request)
- CONNECTIONS with flanges: UNI 2223-2229 AND DIN 2501 BL.1
- FLANGE DRILLING: METRIC
- BLOW-OUT PROOF stem with antistatic device
- For general applications and special versions see technical table of manual valve
- In the below table the part number and the valve code refer to the standard valve **PN 16** and **PN 40** where applicable



SIZE	PART NUMBER	weight in gr.	A	B	C	E	F	G	I	L	PN	ACTUATOR code	VALVE code	MOUNTING KIT code
DN50	S91AA60900	16720	222	120	140	292,5	82,5	M16	125	85	40	SNA1104X00	V901X609	K1GA0108
DN65	S91AA61000	27620	300	137	160	337	92,5	M16	145	103	16	SNA1274X00	V901X610	K1GA0110
DN65	S92AA61000	27420	300	137	160	337	92,5	M16	145	103	40	SNA1274X00	V902X610	K1GA0110
DN80	S91AA61100	41690	380	172	198	395	100	M16	160	122	40	SNA1604X00	V901X611	K1GA0111
DN100	S91AA61200	54270	380	172	198	430	110	M16	180	155	16	SNA1605X00	V901X612	K1GA0112
DN100	S92AA61200	58770	380	172	198	430	117,5	M20	190	155	40	SNA1605X00	V902X612	K1GA0112
DN125	S91AA61300	93000	450	224	255	492	128	M16	210	170*	16	SNA2104X00	V901X613	K1GA0113
DN150	S91AA61400	171000	683	272	302	594	148	M20	240	210*	16	SNA2544X00	V901X614	K1GA0114
DN200	S91AA61500	261000	603	272	302	634	183	M20	295	310*	16	SNA2554X00	V901X615	K1GA0115

* from 2005 DN125 : L 185 DN150 : L 235 DN200 : L 315

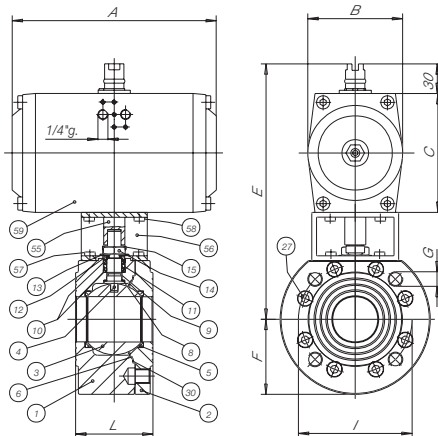

LIST OF VALVE COMPONENTS AND MATERIALS

REF.	PART	QTY	MATERIAL
1	BODY	1	AISI 316/CF8M
2	FLANGE	1	AISI 316
3	BALL	1	AISI 316
4	STEM	1	AISI 316
5	SEAT	2	PTFE
6	SIDE SEALING RING	1	PTFE
8	UPPER RING	3	PTFE
9	STEM O-RING	1	VITON
10	UPPER SEALING COUPLE	1	PTFE
11	PACKING GLAND	1	AISI 304
12	WASHER	1	AISI 304
13	BELLEVILLE WASHERS	2	AISI 301
14	STEM RETAINING NUT	1	AISI 304
15	FIXING NUT PLATE	1	AISI 304
27	FLANGE LOCKING SCREW	8	AISI 304
30	SIDE SEALING RING	1	GRAPHITE
55	ACTUATOR SHAFT	1	C.S
56	BRACKET	1	C.S
57	BRACKET/VALVE SCREW	4	8.8
58	BRACKET/ACTUATOR SCREW	4	8.8
59	ACTUATOR	1	

For accessories see relevant catalogue sheet

SELENE A 105

WAFER SPLIT BODY BALL VALVE – FULL BORE

MAIN STANDARD FEATURES

- CONSTRUCTION: ASTM A 105
- General prescriptions: BS 5351
- Certifications: FIRE SAFE to: BS 6755 - API 6 FA - API 607 up to DN100
TÜV for TA Luft up to DN100
- DIAMETER: from DN 50 to DN 200
- PRESSURES: PN 16/40 from DN 50 to DN 100
PN 16 from DN 125 to DN 200
- TEMPERATURE LIMITS: from -10°C to +180°C
- CONNECTIONS with flanges: UNI 2223-2229 and DIN 2501 BL.1
- FLANGE DRILLING: METRIC
- BLOW-OUT PROOF stem with antistatic device
- WRAPPING SEATS
- ISO 5211 mounting plate for actuators
- OPERATION device: lever handle
- BOLTED flange for ball retaining



STANDARD PART NUMBERS

Art. 2903

PN16

Art. 2904

PN40

SPECIAL EXECUTIONS

- 15% GLASS-FILLED PTFE with temperature limits -10°C + 195°C
- PTFE+CARBOGRAPHITE with temperature limits -10°C + 210°C
- Integral seats in PTFE up to DN100
- DN 125 to DN 200 PN 25/40
- Reduction gear with manual operation
- Stem extensions: 50 mm or 100 mm up to DN 100
- Yellow lever handle for gas up to DN100
- Body in LF2 up to -20°C
- On request the valve is available with ATEX certificate
- For further special requests please consult our technical/commercial service

GENERAL APPLICATIONS

Use as an ON-OFF valve for: installations for gas, water, air distribution. Suitable for vacuum 1-10-3 STD CC, steam up to +195°C with PTFE+CARBOGRAPHITE and for industrial plants in general. Thanks to its reduced face to face dimensions and its intrinsic features it offers wide applications in new projects also as an alternative to the standard split body valve. For special utilizations ascertain the compatibility with process features and the corrosion resistance also by the relevant table.

LIST OF COMPONENTS AND MATERIALS

REF.	PART	MATERIAL	DIN MAT.	QTY
1	BODY	ASTM A105		1
2	FLANGE	ASTM A105		1
3	BALL	AISI 304	1.4301	1
4	STEM	AISI 304	1.4301	1
5	SEAT	PTFE		2
6	SIDE SEALING RING	PTFE		1
8	UPPER RING	PTFE		2
9	STEM O-RING	VITON		1
10	UPPER SEALING COUPLE	PTFE		2
11	PACKING GLAND	AISI 304	1.4301	2
12	OPERATION STOP	AISI 304		1
13	BELLEVILLE WASHERS	50CrV4		2
14	STEM RETAINING NUT	AISI 304		1
15	FIXING NUT PLATE	AISI 304	1.4301	1
17	LOCKING NUT	AISI 304		1
18	LEVER HANDLE	AISI 304		1
19	OPERATION STOP SCREW	AISI 304		1
27	FLANGE LOCKING SCREW	AISI 304		1
30	SIDE SEALING RING	GRAPHITE		1
31	V SHAPED CHEVRON TYPE	PTFE+GRAPHITE		1
32	UPPER RING	PTFE		1

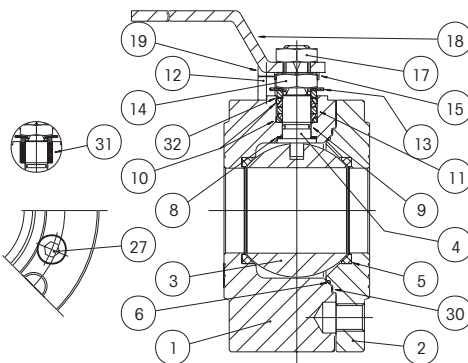

SELENE A 105

WAFER SPLIT BODY BALL VALVE - FULL BORE

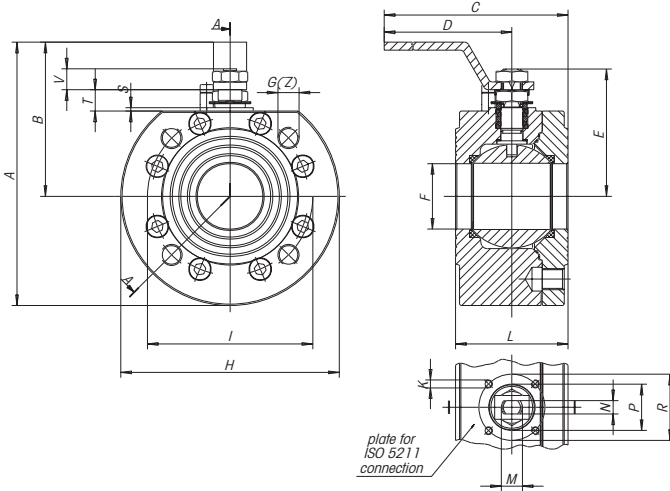

FLANGE DRILLINGS UNI2223-67

SIZE	A	B
DN65	M16	20
DN80	M16	24
DN100	M16	20
DN100	M20	24
DN125	M16	22
DN150	M20	22
DN200	M20	24

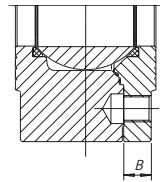

SIZE	A	B	C	D	E	F	G	H	K	I	L	M	N	P	R	S	T	V	N Holes	PN	ISO	Weight in gr.
DN40	183	108	273	230	87	40	M16	150	M6	110	76	M16	10	-	50	-	10	14	4	40	F05	8750
DN50	199	117	273	230	94.5	49.5	M16	165	M6	125	85	M16	10	35	50	2.5	16	14	4	40	F05	11000
DN65	232	139	372	320	119.5	65	M16	185	M8	145	103	M22	14	55	70	3	19	20.5	4	16	F07	17500
DN65	232	139	372	320	119.5	65	M16	185	M8	145	103	M22	14	55	70	3	19	20.5	8	40	F07	17300
DN80	249	149	381	320	129.5	78	M16	200	M8	160	122	M22	14	55	70	3	19	20.5	8	40	F07	22800
DN100	277	167	448	370	148.5	96	M16	220	M10	180	155	M27	16	70	102	3	22.2	25.3	8	16	F10	34500
DN100	284	167	448	370	148.5	96	M20	235	M10	190	155	M27	16	70	102	3	22.2	25.3	8	40	F10	39000
DN125	309	181	455	370	166.5	118	M16	255	M10	210	170*	M27	16	70	102	3	22.2	25.3	8	16	F10	51000
DN150	388	241	500	395	197.5	144	M20	259	M12	240	210*	M42	26	-	125	-	4	29	8	16	F12	81000
DN200	458	276	829	674	232.5	192	M20	365	M12	295	310*	M42	26	-	125	-	4	29	12	16	F12	177000

* from 2005 DN125 : L 185 DN150 : L 235 DN200 : L 315

BREAKAWAY TORQUES in Nm

DN size	50	65	80	100	125	150	200
0	35	55	75	150	240	310	600
16	39	59	84.5	168	300	400	800
25	41.5	62.5	92	180			
40	44	67	99	195			

Nm

The values in Nm may vary as a function of the seals material, temperature and type of medium. For a firm operation of the various types of actuators, in the different working conditions it is necessary to consider a safety factor of 1.5. During operation, with frequent open and close cycles, the operating torque can decrease considerably in comparison with the initial breakaway torque.

PRESSURE/TEMPERATURE DIAGRAM

At each pressure level corresponds the admissible temperature level.

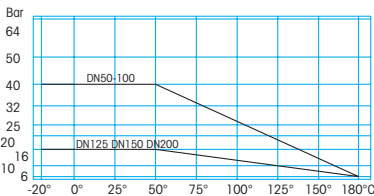

LOSS OF HEAD DIAGRAM/FLOW RATE

The Kv value is the flow rate causing a pressure drop of 1 bar

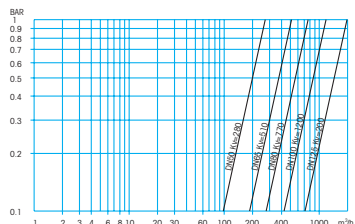

SELENE A 105

WAFER SPLIT BODY BALL VALVE - FULL BORE WITH **DOUBLE ACTING** PNEUMATIC ACTUATOR

ACTUATOR FEATURES

- Rotation angle: 90°
- Standard version for temperature between -20°C and + 90°C
- Supply maximum pressure: 10 bar (8bar for DNA045)
- Nominal pressure: 5,62 bar
- Supply medium: dry filtered compressed air, not necessarily lubricated
- Lubrication: in such a case use a non-detergent or NBR compatible oil

STANDARD VALVE FEATURES

- General prescriptions: BS 5351, Fire safe to: BS 6755-API 6 FA- API 607
- Working temperature: from -20°C to +180°C
- Maximum working pressure with actuator: **PN 16** (PN 25 and 40 on request)
- CONNECTIONS with flanges: UNI 2223-2229 AND DIN 2501 BL.1
- FLANGE DRILLING: METRIC
- BLOW-OUT PROOF stem with antistatic device
- For general applications and special versions see technical table of manual valve
- In the below table the part number and the valve code refer to the standard valve **PN 16** and **PN 40** where applicable



SIZE	PART NUMBER	weight in gr.	A	B	C	E	F	G	I	L	PN	ACTUATOR code	VALVE code	MOUNTING KIT code
DN50	D95AA60900	13700	182	91	108	260.5	82.5	M16	125	85	40	DGA083AX00	V903X609	K1GA0008
DN65	D95AA61000	21215	203	100	117	294	92.5	M16	145	103	16	DGA092AX00	V903X610	K1GA0010
DN65	D96AA61000	21015	203	100	117	294	92.5	M16	145	103	40	DGA092AX00	V904X610	K1GA0010
DN80	D95AA61100	28085	222	120	140	327	100	M16	160	122	40	DNA110AX00	V903X611	K1GA0011
DN100	D95AA61200	43800	300	137	160	382	110	M16	180	155	16	DNA127AX00	V903X612	K1GA0012
DN100	D96AA61200	48300	300	137	160	382	117.5	M20	190	155	40	DNA127AX00	V904X612	K1GA0012
DN125	D95AA61300	77000	380	172	198	430	128	M16	210	170*	16	DNA160AX00	V903X613	K1GA0013
DN150	D95AA61400	114000	450	224	255	542	148	M20	240	210*	16	DNA160AX00	V903X614	K1GA0014
DN200	D95AA61500	224000	450	224	255	564	183	M20	295	310*	16	DNA210AX00	V903X615	K1GA0015

* from 2005 DN125 : L 185 DN150 : L 235 DN200 : L 315

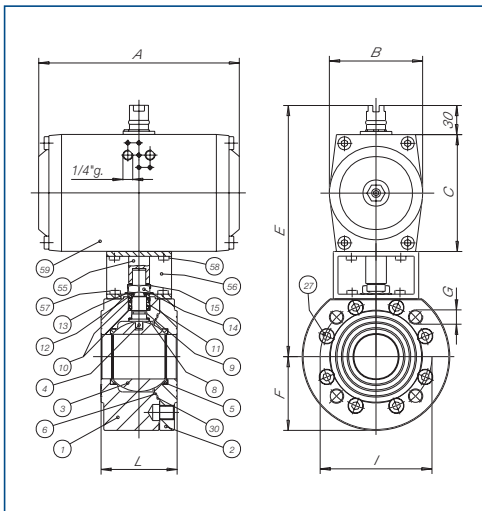

LIST OF VALVE COMPONENTS AND MATERIALS

REF.	PART	QTY	MATERIAL
1	BODY	1	ASTM A105
2	FLANGE	1	ASTM A105
3	BALL	1	AISI 304
4	STEM	1	AISI 304
5	SEAT	2	PTFE
6	SIDE SEALING RING	1	PTFE
8	UPPER RING	3	PTFE
9	STEM O-RING	1	VITON
10	UPPER SEALING COUPLE	1	PTFE
11	PACKING GLAND	1	AISI 304
12	WASHER	1	AISI 304
13	BELLEVILLE WASHERS	2	50CrV4
14	STEM RETAINING NUT	1	AISI 304
15	FIXING NUT PLATE	1	AISI 304
27	FLANGE LOCKING SCREW	8	AISI 304
30	SIDE SEALING RING	1	GRAPHITE
55	ACTUATOR SHAFT	1	C.S.
56	BRACKET	1	C.S.
57	BRACKET/VALVE SCREW	4	8.8
58	BRACKET/ACTUATOR SCREW	4	8.8
59	ACTUATOR	1	

For accessories see relevant catalogue sheet

SELENE A 105

WAFER SPLIT BODY BALL VALVE - FULL BORE WITH **SPRING RETURN PNEUMATIC ACTUATOR**

ACTUATOR FEATURES

- Rotation angle: 90°
- Standard version for temperature between -20°C and + 90°C
- Supply maximum pressure: 10 bar
- Nominal pressure: 5,62 bar
- Supply medium: dry filtered compressed air, not necessarily lubricated
- Lubrication: in such a case use a non-detergent or NBR compatible oil
- STANDARD: **SPRING CLOSES/AIR OPENS**, clockwise automatic closing

STANDARD VALVE FEATURES

- General prescriptions: BS 5351, Fire safe to: BS 6755-API 6 FA- API 607
- Working temperature: from -20°C to +180°C
- Maximum working pressure with actuator: **PN 16** (PN 25 and 40 on request)
- CONNECTIONS with flanges: UNI 2223-2229 AND DIN 2501 BL.1
- FLANGE DRILLING: METRIC
- BLOW-OUT PROOF stem with antistatic device
- For general applications and special versions see technical table of manual valve
- In the below table the part number and the valve code refer to the standard valve **PN 16** and **PN 40** where applicable



SIZE	PART NUMBER	weight in gr.	A	B	C	E	F	G	I	L	PN	ACTUATOR code	VALVE code	MOUNTING KIT code
DN50	S95AA60900	16720	222	120	140	292,5	82,5	M16	125	85	40	SNA1104X00	V903X609	K1GA0108
DN65	S95AA61000	27620	300	137	160	337	92,5	M16	145	103	16	SNA1274X00	V903X610	K1GA0110
DN65	S96AA61000	27420	300	137	160	337	92,5	M16	145	103	40	SNA1274X00	V904X610	K1GA0110
DN80	S95AA61100	41690	380	172	198	395	100	M16	160	122	40	SNA1604X00	V903X611	K1GA0111
DN100	S95AA61200	54270	380	172	198	430	110	M16	180	155	16	SNA1605X00	V903X612	K1GA0112
DN100	S96AA61200	58770	380	172	198	430	117,5	M20	190	155	40	SNA1605X00	V904X612	K1GA0112
DN125	S95AA61300	93000	450	224	255	492	128	M16	210	170*	16	SNA2104X00	V903X613	K1GA0113
DN150	S95AA61400	171000	683	272	302	594	148	M20	240	210*	16	SNA2544X00	V903X614	K1GA0114
DN200	S95AA61500	261000	603	272	302	634	183	M20	295	310*	16	SNA2554X00	V903X615	K1GA0115

* from 2005 DN125 : L 185 DN150 : L 235 DN200 : L 315

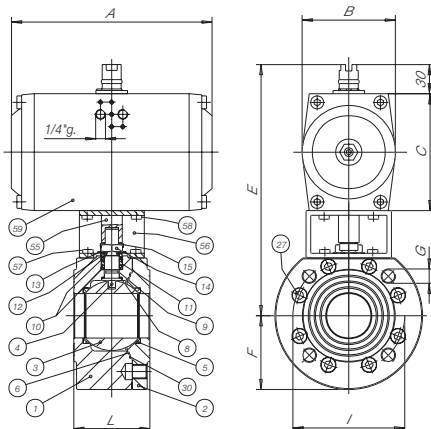

LIST OF VALVE COMPONENTS AND MATERIALS

REF.	PART	QTY	MATERIAL
1	BODY	1	ASTM A105
2	FLANGE	1	ASTM A105
3	BALL	1	AISI 304
4	STEM	1	AISI 304
5	SEAT	2	PTFE
6	SIDE SEALING RING	1	PTFE
8	UPPER RING	3	PTFE
9	STEM O-RING	1	VITON
10	UPPER SEALING COUPLE	1	PTFE
11	PACKING GLAND	1	AISI 304
12	WASHER	1	AISI 304
13	BELLEVILLE WASHERS	2	50CrV4
14	STEM RETAINING NUT	1	AISI 304
15	FIXING NUT PLATE	1	AISI 304
27	FLANGE LOCKING SCREW	8	AISI 304
30	SIDE SEALING RING	1	GRAPHITE
55	ACTUATOR SHAFT	1	C.S.
56	BRACKET	1	C.S.
57	BRACKET/VALVE SCREW	4	8.8
58	BRACKET/ACTUATOR SCREW	4	8.8
59	ACTUATOR	1	

For accessories see relevant catalogue sheet

ANTARES AISI 316

SPLIT BODY BALL VALVE - FULL BORE

MAIN STANDARD FEATURES

- CONSTRUCTION: AISI 316
- General prescriptions: BS 5351
- Certifications: FIRE SAFE to: BS 6755 - API 6 FA - API 607
TÜV for TA Luft
- DIAMETER: from DN 15-1/2" to DN 150-6"
- PRESSURES: PN 16/40 from DN 15 to DN 50
PN 16 from DN 65 to DN 150
ANSI 150 from 1/2" to 6"
- TEMPERATURE LIMITS: from -20°C to +180°C
- CONNECTIONS: flanges to UNI 2223-2229 and DIN 2501 BL.1
DIN 3202 face to face F4
flanges to ANSI 150 RF - ANSI B16.5 -
ANSI B16.10 face to face
- BLOW-OUT PROOF stem with antistatic device (from DN40)
- WRAPPING SEATS
- TRIPLE stem-packing with labyrinth effect and automatic adjustment by Belleville washers
- ISO 5211 mounting plate for actuators
- OPERATION device: lever handle



STANDARD PART NUMBERS

Art. 2921	Art. 2922	Art. 2924
ANSI 150 RF	DIN face to face F4	DIN face to face F1

SPECIAL EXECUTIONS

- 15% GLASS-FILLED PTFE with temperature limits -20°C + 195°C
- PTFE + CARBOGRAPHITE with temperature limits -20°C + 210°C
- From DN 65 to DN 150 PN 25/40
- From DN15 to DN 100, PN16/40, DIN3202 face to face F1
- From 1/2" to 6" ANSI 300
- DN 200 PN 16, and 8" ANSI 150 (with application of reduction gear)
- Yellow lever handle for gas
- Degreased version
- Antistatic device from DN15 to DN32
- On request the valve is available with ATEX certificate
- For further special requests please consult our technical/commercial service

GENERAL APPLICATIONS

Use as an ON-OFF valve for: chemical products, food, installations for gas, water, air distribution. Suitable for vacuum up to 1x10⁻³ STD CC/SEC, steam up to +195°C with PTFE+CARBOGRAPHITE. Thanks to its firm standardizations it is among the most used valves in all industrial plants.

For special utilizations ascertain the compatibility with process features and the corrosion resistance also by the relevant table.

LIST OF COMPONENTS AND MATERIALS

REF.	PART	MATERIAL	DIN MAT.	QTY
1	BODY	AISI 316	1.4401	1
2	BODY FLANGE	AISI 316	1.4401	1
3	BALL	AISI 316	1.4401	1
4	STEM	AISI 316	1.4401	1
5	SEAT	PTFE		2
6	FLANGE SEAL	PTFE		1
8	STEM SEAL	PTFE		1
9	STEM O-RING	VITON		1
10	UPPER SEAL	PTFE		1
11	PACKING GLAND	AISI 316	1.4401	1
13	BELLEVILLE WASHERS	S.S.		2
14	STEM RETAINING NUT	AISI 304	1.4301	1
17	LOCKING NUT	AISI 304	1.4301	1
18	LEVER HANDLE	C.S. GALV.		1
35	OPERATION STOP PIN	AISI 304	1.4301	1
36	STUD BOLT	A 193 B8		4
37	NUT	A 194 8A		4

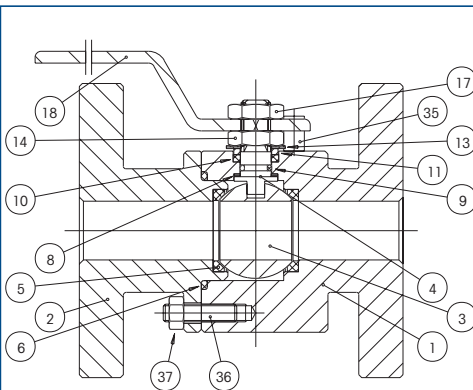

ANTARES AISI 316

SPLIT BODY BALL VALVE - FULL BORE

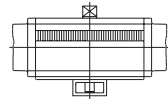
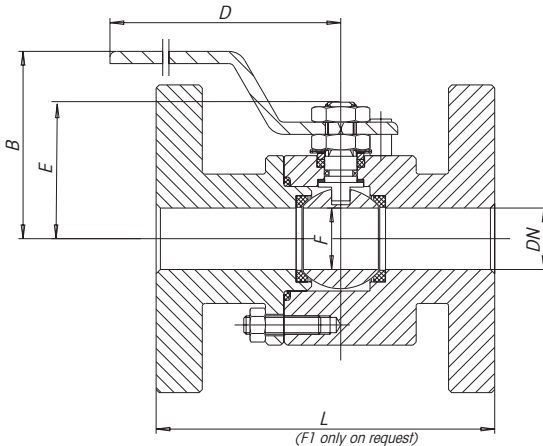

By removing the lever handle, the ANTARES valve can be assembled directly with an actuator by means of a bracket with screws, the stem adapter and by replacing the operation stop (part 35) of the valve (kit supplied upon request).

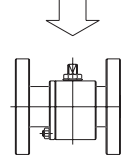

DIN SERIES

serie ANSI 150

SIZE	B	D	E	F	L F4	L F1	PN	ISO	Weight in gr.	SIZE	B	D	E	F	L	ISO	Weight in gr.
DN15	66	140	48	15	115	130	16/40	F03	3600	1/2"	66	140	48	15	108	F03	3600
DN20	69	140	51	20	120	150	16/40	F03	4635	3/4"	69	140	51	20	117	F03	3750
DN25	82	180	62,5	25	125	160	16/40	F04	5750	1"	82	180	62,5	25	127	F04	5525
DN32	87	180	67	32	130	180	16/40	F04	8320	1" 1/4	87	180	67	32	140	F04	8320
DN40	108	230	87,5	40	140	200	16/40	F05	11160	1" 1/2	108	230	87,5	40	165	F05	10260
DN50	115	230	94,5	49,5	150	230	16/40	F05	14900	2"	115	230	94,5	49,5	178	F05	13755
DN65	139	320	119,5	65	170	290	16	F07	23750	2" 1/2	139	320	119,5	65	190	F07	23130
DN80	150	320	130	78	180	310	16/40	F07	28530	3"	150	320	130	78	203	F07	29235
DN100	163	370	148,5	96	190	350	16	F10	35560	4"	163	370	148,5	96	229	F10	39385
DN150	249	584	200	144	350	480	16	F12	108900	6"	249	584	200	144	394	F12	114100

BREAKAWAY TORQUES in Nm

PN - bar	DN size	15	20	25	32	40	50	65	80	100
0	0	4	7	15	21	26	36	51	81	130
16	0	5	8	17	23	28	39	54	86	150
40	0	6	10	22	28	32	45	62	120	200

Nm

The values in Nm may vary as a function of the seals material, temperature and type of medium. For a firm operation of the various types of actuators, in the different working conditions it is necessary to consider a safety factor of 1.5. During operation, with frequent open and close cycles, the operating torque can decrease considerably in comparison with the initial breakaway torque.

PRESSURE/TEMPERATURE DIAGRAM

At each pressure level corresponds the admissible temperature level.

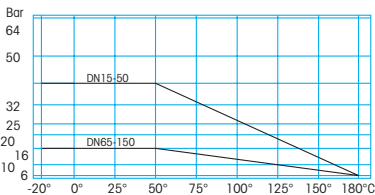

LOSS OF HEAD DIAGRAM/FLOW RATE

The Kv value is the flow rate causing a pressure drop of 1 bar

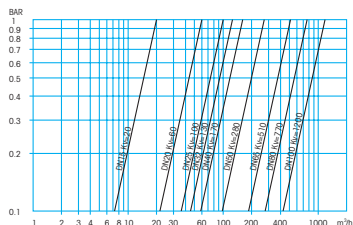

ANTARES AISI 316

SPLIT BODY BALL VALVE - FULL BORE WITH **DOUBLE ACTIVE PNEUMATIC ACTUATOR**

ACTUATOR FEATURES

- Rotation angle: 90°
- Standard version for temperature between -20°C and + 90°C
- Supply maximum pressure: 10 bar (8bar for DNA045)
- Nominal pressure: 5,62 bar
- Supply medium: dry filtered compressed air, not necessarily lubricated
- Lubrication: in such a case use a non-detergent or NBR compatible oil

STANDARD VALVE FEATURES

- General prescriptions: BS 5351, Fire safe to: BS 6755-API 6 FA- API 607
- Working temperature: from -20°C to +180°C
- Maximum working pressure with actuator: PN 16 (PN 25 and 40 on request)
- CONNECTIONS with flanges: UNI 2223-2229 AND DIN 2501 BL.1
DIN 3202 face to face
ANSI 150 RF - ANSI B16.5
ANSI B16.10 face to face
- BLOW-OUT PROOF stem with antistatic device
- For general applications and special versions see technical table of manual valve
- In the below table the part number and the valve code refer to the standard valve UNI/DIN PN 16 and PN 40 where applicable



SIZE	PART NUMBER	weight in gr.	A	B	C	E DIN	L F4	L F1	E ANSI150	L ANSI150	PN	ACTUATOR code	VALVE code	MOUNTING KIT code
DN15	D22AA60400		110	53	68	172	115	130	172	108	16/40	DNA045AZ00	3922X604	K1GA0504
DN20	D22AA60500		110	53	68	172	120	150	172	117	16/40	DNA045AZ00	3922X605	K1GA0004
DN25	D22AA60600		127	59	74	193	125	160	193	127	16/40	DGA052AX00	3922X606	K1GA0006
DN32	D22AA60700		133	70	88	214	130	180	214	140	16/40	DGA063AX00	3922X607	K1GA0007
DN40	D22AA60800		132	83	100	237	140	200	237	165	16/40	DGA075AX00	3922X608	K1GA0008
DN50	D22AA60900		182	91	108	253	150	230	253	178	16/40	DGA083AX00	3922X609	K1GA0008
DN65	D22AA61000		203	100	117	287	170		287	190	16	DGA092AX00	3922X610	K1GA0010
DN80	D22AA61100		222	120	140	321	180		321	203	16/40	DNA110AX00	3922X611	K1GA0011
DN100	D22AA61200		300	137	160	391	190		391	229	16	DNA127AX00	3922X612	K1GA0012

For ANSI 150 series the codes become: PART NUMBER = D21AA60400 + 61200, VALVE code = 3921X604 + 612

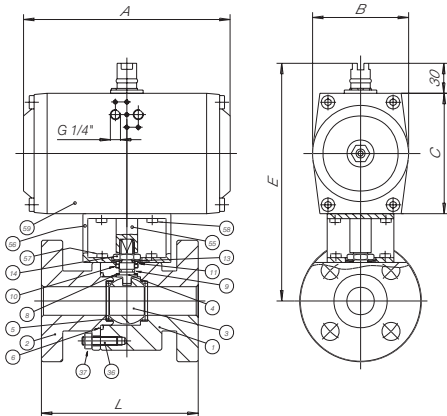

LIST OF VALVE COMPONENTS AND MATERIALS

REF.	PART	QTY	MATERIAL
1	BODY	1	AISI 316
2	BODY FLANGE	1	AISI 316
3	BALL	1	AISI 316
4	STEM	1	AISI 316
5	SEAT	2	PTFE
6	FLANGE SEAL	1	PTFE
8	STEM SEAL	1	PTFE
9	STEM O-RING	1	VITON
10	UPPER SEAL	1	PTFE
11	PACKING GLAND	1	AISI 316
13	BELLEVILLE WASHERS	2	S.S.
14	STEM RETAINING NUT	1	S.S.
36	STUD BOLT	1	A 193 B8
37	NUT	1	A 194 8A
55	ACTUATOR SHAFT	1	S.S.
56	BRACKET	1	S.S.
57	BRACKET/VALVE SCREW	4	8.8
58	BRACKET/ACTUATOR SCREW	4	8.8
59	ACTUATOR	1	

For accessories see relevant catalogue sheet

ANTARES AISI 316

SPLIT BODY BALL VALVE - FULL BORE WITH **SPRING RETURN PNEUMATIC ACTUATOR**

ACTUATOR FEATURES

- Rotation angle: 90°
- Standard version for temperature between -20°C and + 90°C
- Supply maximum pressure: 10 bar
- Nominal pressure: 5,62 bar
- Supply medium: dry filtered compressed air, not necessarily lubricated
- Lubrication: in such a case use a non-detergent or NBR compatible oil
- STANDARD: SPRING CLOSES/AIR OPENS, clockwise automatic closing

STANDARD VALVE FEATURES

- General prescriptions: BS 5351, Fire safe to BS 6755 – API 6 FA – API 607
- Working temperature: from -20°C to +180 °C
- Maximum working pressure with actuator: PN 16 (PN 25 and 40 on request)
- CONNECTIONS with flanges: UNI 2223-2229 and DIN 2501 BL.1
DIN 3202 face to face
ANSI 150 RF – ANSI B16.5
ANSI B16.10 face to face
- BLOW-OUT PROOF stem with antistatic device
- For general applications and special versions see technical table of manual valve
- In the below table the part number and the valve code refer to the standard valve UNI/DIN PN 16 and PN 40 where applicable



SIZE	PART NUMBER	weight in gr.	A	B	C	E DIN	L	F4	L F1	E ANS150	L ANS150	PN	ACTUATOR code	VALVE code	MOUNTING KIT code
DN15	S22AA60400		127	59	74	178	115	130	178	108	16/40	SGA0524X00	3922X604	K1GA0604	
DN20	S22AA60500		133	70	88	192	120	150	192	117	16/40	SGA0634X00	3922X605	K1GA0005	
DN25	S22AA60600		132	83	100	219	125	160	219	127	16/40	SGA0754X00	3922X606	K1GA0106	
DN32	S22AA60700		182	91	108	234	130	180	234	140	16/40	SGA0834X00	3922X607	K1GA0107	
DN40	S22AA60800		203	100	117	254	140	200	254	165	16/40	SGA0924X00	3922X608	K1GA0108	
DN50	S22AA60900		222	120	140	285	150	230	285	178	16/40	SNA1104X00	3922X609	K1GA0108	
DN65	S22AA61000		300	137	160	330	170	330	390	190	16	SNA1274X00	3922X610	K1GA0110	
DN80	S22AA61100		380	172	198	379	180	479	379	203	16/40	SNA1604X00	3922X611	K1GA0111	
DN100	S22AA61200		380	172	198	429	190	429	229	16	16	SNA1605X00	3922X612	K1GA0312	

For ANSI 150 series the codes become: PART NUMBER = S21AA60400 + 61200, VALVE code = 3921X604 + 612

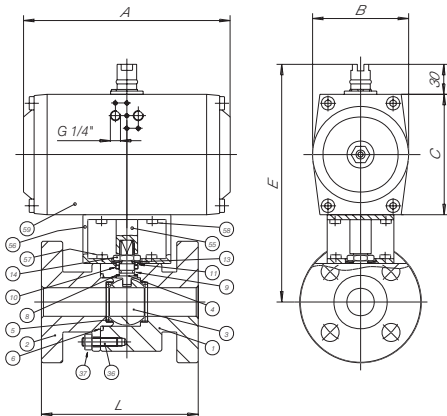

LIST OF VALVE COMPONENTS AND MATERIALS

REF.	PART	QTY	MATERIAL
1	BODY	1	AISI 316
2	BODY FLANGE	1	AISI 316
3	BALL	1	AISI 316
4	STEM	1	AISI 316
5	SEAT	2	PTFE
6	FLANGE SEAL	1	PTFE
8	STEM SEAL	1	PTFE
9	STEM O-RING	1	VITON
10	UPPER SEAL	1	PTFE
11	PACKING GLAND	1	AISI 316
13	BELLEVILLE WASHERS	2	S.S.
14	STEM RETAINING NUT	1	AISI 304
36	STUD BOLT	1	A 193 B8
37	NUT	1	A 194 8A
55	ACTUATOR SHAFT	1	C.S.
56	BRACKET	1	C.S.
57	BRACKET/VALVE SCREW	4	8.8
58	BRACKET/ACTUATOR SCREW	4	8.8
59	ACTUATOR	1	

For accessories see relevant catalogue sheet

ANTARES A 105

SPLIT BODY BALL VALVE - FULL BORE

MAIN STANDARD FEATURES

- CONSTRUCTION: ASTM A 105
- General prescriptions: BS 5351
- Certifications: FIRE SAFE to: BS 6755 - API 6 FA - API 607 TÜV for TA Luft
- DIAMETER: from DN 15-1/2" to DN 150-6"
- PRESSURES: PN 16/40 from DN 15 to DN 50
PN 16 from DN 65 to DN 150
ANSI 150 from 1/2" to 6"
- TEMPERATURE LIMITS: from -10°C to +180°C
- CONNECTIONS: flanges to UNI 2223-2229 and DIN 2501 BL.1
DIN 3202 face to face F4
flanges to ANSI 150 RF - ANSI B16.5 - ANSI B16.10 face to face
- BLOW-OUT PROOF stem with anti-static device (from DN40)
- WRAPPING SEATS
- TRIPLE stem-packing with labyrinth effect and automatic adjustment by Belleville washers
- ISO 5211 mounting plate for actuators
- OPERATION device: lever handle



STANDARD PART NUMBERS

- | | | |
|---------------------------------|---|---|
| Art. 2931
ANSI 150 RF | Art. 2932
DIN face to face F4 | Art. 2934
DIN face to face F1 |
|---------------------------------|---|---|

SPECIAL EXECUTIONS

- 15% GLASS-FILLED PTFE with temperature limits -10°C + 195°C
- PTFE + CARBOGRAPHITE with temperature limits -20°C +210°C
- From DN 65 to DN 150 PN 25/40
- From DN15 to DN100, PN16/40, DIN 3202 face to face F1
- From 1/2" to 6" ANSI 300
- DN 200 PN 16, and 8" ANSI 150 (with application of reduction gear)
- Yellow lever handle for gas
- Anti-static device from DN15 to DN32
- Body in LF2 up to -20°C
- On request the valve is available with ATEX certificate
- For further special requests please consult our technical/commercial service

GENERAL APPLICATIONS

Use as an ON-OFF valve for: installations for gas, water, air distribution. Suitable for vacuum up to 1x10⁻³ STD CC/SEC, steam up to +195°C with PTFE+CARBOGRAPHITE.

Thanks to its firm standardizations it is among the most used valves in all industrial plants.

For special utilizations ascertain the compatibility with process features and the corrosion resistance also by the relevant table.

LIST OF COMPONENTS AND MATERIALS

REF.	PART	MATERIAL	DIN MAT.	QTY
1	BODY	ASTM A105		1
2	BODY FLANGE	ASTM A105		1
3	BALL	AISI 304	1.4301	1
4	STEM	AISI 304	1.4301	1
5	SEAT	PTFE		2
6	FLANGE SEAL	PTFE		1
8	STEM SEAL	PTFE		1
9	STEM O-RING	VITON		1
10	UPPER SEAL	PTFE		1
11	PACKING GLAND	AISI 304	1.4310	1
13	BELLEVILLE WASHERS	50CrV4		2
14	STEM RETAINING NUT	C.S. GALV.		1
17	LOCKING NUT	C.S. GALV.		1
18	LEVER HANDLE	C.S. GALV.		1
35	OPERATION STOP PIN	C.S. 8.8		1
36	STUD BOLT	A 193 B7		4
37	NUT	A 194 2H		4

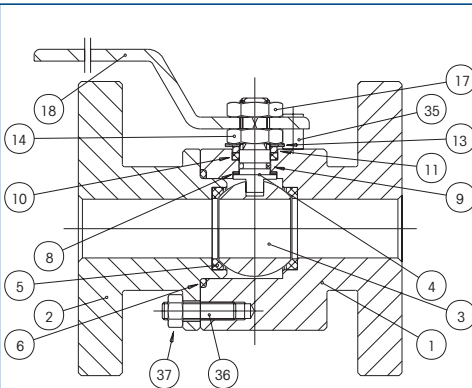

ANTARES A 105

SPLIT BODY BALL VALVE - FULL BORE

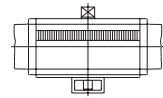
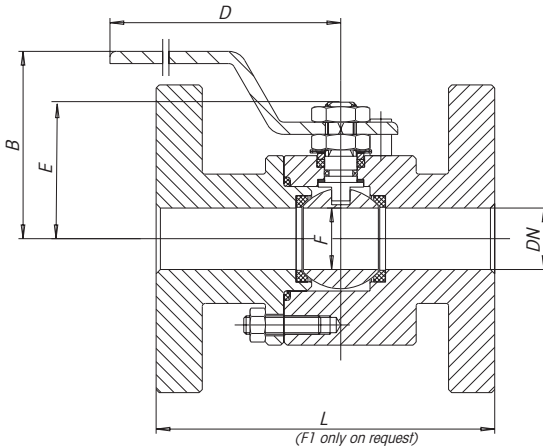

By removing the lever handle, the ANTARES valve can be assembled directly with an actuator by means of a bracket with screws, the stem adapter and by replacing the operation stop (part 35) of the valve (kit supplied upon request).

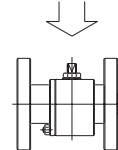

DIN SERIES

ANSI 150 SERIES

SIZE	B	D	E	F	L F4	L F1	PN	ISO	WEIGHT in gr.	SIZE	B	D	E	F	L	ISO	WEIGHT in gr.
DN15	66	140	48	15	115	130	16/40	F03	3600	1/2"	66	140	48	15	108	F03	3600
DN20	69	140	51	20	120	150	16/40	F03	4635	3/4"	69	140	51	20	117	F03	3750
DN25	82	180	62,5	25	125	160	16/40	F04	5750	1"	82	180	62,5	25	127	F04	5525
DN32	87	180	67	32	130	180	16/40	F04	8320	1 1/4"	87	180	67	32	140	F04	8320
DN40	108	230	87,5	40	140	200	16/40	F05	11160	1 1/2"	108	230	87,5	40	165	F05	10260
DN50	115	230	94,5	49,5	150	230	16/40	F05	14900	2"	115	230	94,5	49,5	178	F05	13755
DN65	139	320	119,5	65	170	290	16	F07	23750	2 1/2"	139	320	119,5	65	190	F07	23130
DN80	150	320	130	78	180	310	16/40	F07	28530	3"	150	320	130	78	203	F07	29235
DN100	163	370	148,5	96	190	350	16	F10	35560	4"	163	370	148,5	96	229	F10	39385
DN150	249	584	200	144	350	480	16	F12	108900	6"	249	584	200	144	394	F12	114100

BREAKAWAY TORQUES in Nm

PN - bar	DN size	15	20	25	32	40	50	65	80	100
0		4	7	15	21	26	36	51	81	130
16		5	8	17	23	28	39	54	86	150
40		6	10	22	28	32	45	62	120	200

Nm

The values in Nm may vary as a function of the seals material, temperature and type of medium. For a firm operation of the various types of actuators, in the different working conditions it is necessary to consider a safety factor of 1.5. During operation, with frequent open and close cycles, the operating torque can decrease considerably in comparison with the initial breakaway torque.

PRESSURE/TEMPERATURE DIAGRAM

At each pressure level corresponds the admissible temperature level.

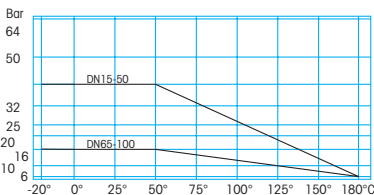

LOSS OF HEAD DIAGRAM/FLOW RATE

The Kv value is the flow rate causing a pressure drop of 1 bar

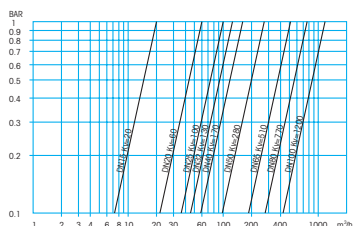

ANTARES A 105

SPLIT BODY BALL VALVE - FULL BORE WITH **DOUBLE ACTING** PNEUMATIC ACTUATOR

ACTUATOR FEATURES

- Rotation angle: 90°
- Standard version for temperature between -20°C and + 90°C
- Supply maximum pressure: 10 bar (8bar for DNA045)
- Nominal pressure: 5,62 bar
- Supply medium: dry filtered compressed air, not necessarily lubricated
- Lubrication: in such a case use a non-detergent or NBR compatible oil

STANDARD VALVE FEATURES

- General prescriptions: BS 5351, Fire safe to: BS 6755-API 6 FA- API 607
- Working temperature: from -20°C to +180°C
- Maximum working pressure with actuator: PN 16 (PN 25 and 40 on request)
- CONNECTIONS with flanges: UNI 2223-2229 AND DIN 2501 BL.1
DIN 3202 face to face
ANSI 150 RF - ANSI B16.5
ANSI B16.10 face to face
- BLOW-OUT PROOF stem with antistatic device
- For general applications and special versions see technical table of manual valve
- In the below table the part number and the valve code refer to the standard valve UNI/DIN PN 16 and PN 40 where applicable



SIZE	PART NUMBER	weight in gr.	A	B	C	E DIN	L F4	L F1	E ANSI150	L ANSI150	PN	ACTUATOR code	VALVE code	MOUNTING KIT code
DN15	D26AA60400		110	53	68	172	115	130	172	108	16/40	DNA045A200	3932X604	K1GA0504
DN20	D26AA60500		110	53	68	172	120	150	172	117	16/40	DNA045A200	3932X605	K1GA0004
DN25	D26AA60600		127	59	74	193	125	160	193	127	16/40	DGA052A200	3932X606	K1GA0006
DN32	D26AA60700		133	70	88	214	130	180	214	140	16/40	DGA063A200	3932X607	K1GA0007
DN40	D26AA60800		132	83	100	237	140	200	237	165	16/40	DGA075A200	3932X608	K1GA0008
DN50	D26AA60900		182	91	108	253	150	230	253	178	16/40	DGA083A200	3932X609	K1GA0009
DN65	D26AA61000		203	100	117	287	170		287	190	16	DGA092A200	3932X610	K1GA0010
DN80	D26AA61100		222	120	140	321	180		321	203	16/40	DNA118A200	3932X611	K1GA0011
DN100	D26AA61200		300	137	160	391	190		391	229	16/40	DNA127A200	3932X612	K1GA0012

For ANSI 150 series the codes become: PART NUMBER = D25AA60400 + 61200, VALVE code = 3931X604-612

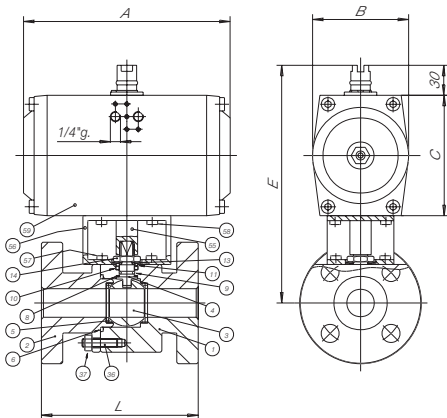

LIST OF VALVE COMPONENTS AND MATERIALS

REF.	PART	QTY	MATERIAL
1	BODY	1	ASTM A105
2	BODY FLANGE	1	ASTM A105
3	BALL	1	AISI 304
4	STEM	1	AISI 304
5	SEAT	2	PTFE
6	FLANGE SEAL	1	PTFE
8	STEM SEAL	1	PTFE
9	STEM O-RING	1	VITON
10	UPPER SEAL	1	PTFE
11	PACKING GLAND	1	AISI 304
13	BELLEVILLE WASHERS	2	50CrV4
14	STEM RETAINING NUT	1	C.S.
36	STUD BOLT	1	A 193 B7
37	NUT	1	A 194 2H
55	ACTUATOR SHAFT	1	C.S.
56	BRACKET	1	C.S.
57	BRACKET/VALVE SCREW	4	8.8
58	BRACKET/ACTUATOR SCREW	4	8.8
59	ACTUATOR	1	

For accessories see relevant catalogue sheet

ANTARES A 105

SPLIT BODY BALL VALVE - FULL BORE WITH **SPRING RETURN PNEUMATIC ACTUATOR**

ACTUATOR FEATURES

- Rotation angle: 90°
- Standard version for temperature between -20°C and + 90°C
- Supply maximum pressure: 10 bar
- Nominal pressure: 5,62 bar
- Supply medium: dry filtered compressed air, not necessarily lubricated
- Lubrication: in such a case use a non-detergent or NBR compatible oil
- STANDARD: SPRING CLOSES/AIR OPENS, clockwise automatic closing

STANDARD VALVE FEATURES

- General prescriptions: BS 5351, Fire safe to BS 6755 - API 6 FA - API 607
- Working temperature: from -20°C to +180 °C
- Maximum working pressure with actuator: PN 16 (PN 25 and 40 on request)
- CONNECTIONS with flanges: UNI 2223-2229 and DIN 2501 BL.1
DIN 3202 face to face
ANSI 150 RF - ANSI B16.5
ANSI B16.10 face to face
- BLOW-OUT PROOF stem with antistatic device
- For general applications and special versions see technical table of manual valve
- In the below table the part number and the valve code refer to the standard valve UNI/DIN PN 16 and PN 40 where applicable



SIZE	PART NUMBER	weight in gr.	A	B	C	E DIN	L F4	L F1	E ANSI 150	L ANSI 150	PN	ACTUATOR code	VALVE code	MOUNTING KIT code
DN15	S26AA60400		127	59	74	178	115	130	178	108	16/40	SGA0524X00	3932X604	K1GA0604
DN20	S26AA60500		133	70	88	192	120	150	192	117	16/40	SGA0634X00	3932X605	K1GA0005
DN25	S26AA60600		132	83	100	219	125	160	219	127	16/40	SGA0754X00	3932X606	K1GA0106
DN32	S26AA60700		182	91	108	234	130	180	234	140	16/40	SGA0834X00	3932X607	K1GA0107
DN40	S26AA60800		203	100	117	254	140	200	254	165	16/40	SGA0924X00	3932X608	K1GA0108
DN50	S26AA60900		222	120	140	285	150	230	285	178	16/40	SNA1104X00	3932X609	K1GA0108
DN65	S26AA61000		300	137	160	330	170	330	390	190	16	SNA1274X00	3932X610	K1GA0110
DN80	S26AA61100		380	172	198	379	180	379	203	16/40	SNA1604X00	3932X611	K1GA0111	
DN100	S26AA61200		380	172	198	429	190	429	229	16	SNA1605X00	3932X612	K1GA0312	

For ANSI 150 series the codes become: PART NUMBER = D25AA60400, VALVE code = 3931X604 + 12

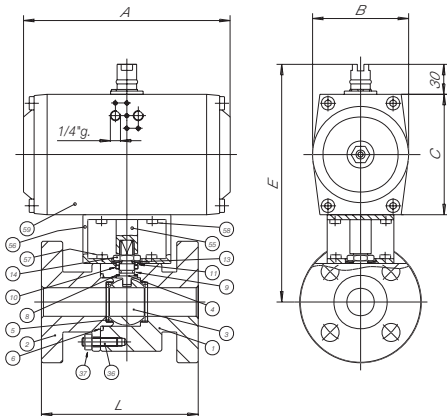

LIST OF VALVE COMPONENTS AND MATERIALS

REF.	PART	QTY	MATERIAL
1	BODY	1	ASTM A105
2	BODY FLANGE	1	ASTM A105
3	BALL	1	AISI 304
4	STEM	1	AISI 304
5	SEAT	2	PTFE
6	FLANGE SEAL	1	PTFE
8	STEM SEAL	1	PTFE
9	STEM O-RING	1	VITON
10	UPPER SEAL	1	PTFE
11	PACKING GLAND	1	AISI 304
13	BELLEVILLE WASHERS	2	50CrV4
14	STEM RETAINING NUT	1	C.S.
36	STUD BOLT	1	A 193 B7
37	NUT	1	A 194 2H
55	ACTUATOR SHAFT	1	C.S.
56	BRACKET	1	C.S.
57	BRACKET/VALVE SCREW	4	8.8
58	BRACKET/ACTUATOR SCREW	4	8.8
59	ACTUATOR	1	

For accessories see relevant catalogue sheet

OLYMPIC

FLANGED BALL VALVE - FULL BORE, WITH **DOUBLE ACTING** PNEUMATIC ACTUATOR

ACTUATOR FEATURES

- Rotation angle: 90°
- Standard version for temperature between -20°C and + 90°C
- Supply maximum pressure: 10 bar (8bar for DNA045)
- Nominal pressure: 5,62 bar
- Supply medium: dry filtered compressed air, not necessarily lubricated
- Lubrication: in such a case use a non-detergent or NBR compatible oil

STANDARD VALVE FEATURES

- Temperature limits: for fluids from -15°C to +120°C
- Working pressure: for fluids 16 bar for all sizes
- CONNECTIONS flanges to UNI2249 and 2229 (raised face PN16) overall length to ISO5752 (table 6 medium series PN16)
- Stem with double conical sealing by 4 seats
- For general applications and special versions see technical table of manual valve
- In the below table the part number and the valve code refer to the standard valve female/male



SIZE	Part Number	Weight in gr.	A	B	C	E	F	G	I	L	N	ACTUATOR code	VALVE code	MOUNTING KIT code
DN 20	D16AA60500	2745	110	53	68	52,5	153	14	75	130	20	DNA045AW00	V116N605	KABBO005
DN 25	D16AA60600	3787	127	59	74	57,5	175	14	85	140	25	DGA052AX00	V116N606	KABBO006
DN 32	D16AA60700	5920	133	70	88	70	201	18	100	165	32	DGA063AX00	V116N607	KABBO007
DN 40	D16AA60800	7238	133	70	88	75	208,5	18	110	165	40	DGA063AX00	V116N608	KABBO008
DN 50	D16AA60900	10335	132	83	100	82,5	228,5	18	125	203	50	DGA075AX00	V116N609	KABBO009
DN 65	D16AA61000	15570	203	100	117	92,5	270	18	145	222	65	DGA092AX00	V116N610	KABBO010
DN 80	D16AA61100	22545	222	120	140	100	303,5	18	160	241	80	DNA110AX00	V116N611	KABBO011
DN 100	D16AA61200	34650	300	137	160	100	336,5	18	180	305	100	DNA127AX00	V116N612	KABBO011

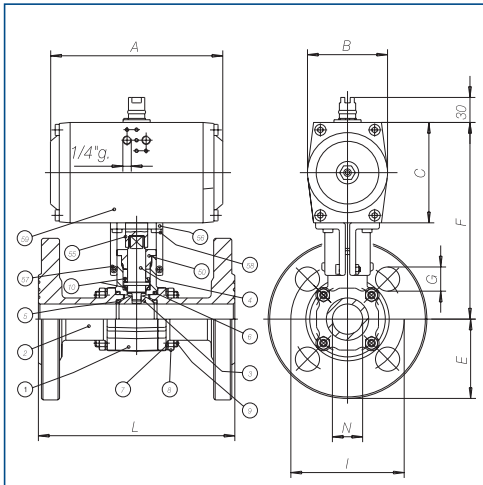

LIST OF VALVE COMPONENTS AND MATERIALS

REF.	PART	Qty	MATERIAL
1	BODY	1	CW617N (OT58)
2	FLANGE	2	CW617N (OT58)
3	BALL	1	CW614N (OT58)
4	STEM	1	CW614N (OT58)
5	SEAT	2	PTFE
6	FLANGE SEALING O-RING	2	VITON
7	WASHER	8	C72
8	NUT	8	4A
9	TIE ROD	4	8,8
10	UPPER SEALING COUPLE	2	PTFE
50	GLAND	1	CW614N (OT58)
55	ACTUATOR SHAFT	1	ALUMINIUM
56	BRACKET	1	ALUMINIUM
57	BRACKET/VALVE SCREW	2	8,8
58	BRACKET/ACTUATOR SCREW	4	8,8
59	ACTUATOR	1	

For accessories see relevant catalogue sheet

OLYMPIC

FLANGED BALL VALVE - FULL BORE, WITH **SPRING RETURN PNEUMATIC ACTUATOR**

ACTUATOR FEATURES

- Rotation angle: 90°
- Standard version for temperature between -20°C and + 90°C
- Supply maximum pressure: 10 bar
- Nominal pressure: 5,62 bar
- Supply medium: dry filtered compressed air, not necessarily lubricated
- Lubrication: in such a case use a non-detergent or NBR compatible oil
- STANDARD: SPRING CLOSES/AIR OPENS, clockwise automatic closing

STANDARD VALVE FEATURES

- Temperature limits: for fluids from -15°C to +120°C
- Working pressure: for fluids 16 bar for all sizes
- CONNECTIONS flanges to UNI2249 and 2229 (raised face PN16) overall length to ISO5752 (table 6 medium series PN16)
- Stem with double conical sealing by 4 seals
- For general applications and special versions see technical table of manual valve
- In the below table the part number and the valve code refer to the standard valve female/female



SIZE	Part Number	Weight in gr.	A	B	C	E	F	G	I	L	N	ACTUATOR code	VALVE code	Mounting Kit code
DN 20	S16AA60500	3825	133	70	88	52.5	173	14	75	130	20	SGA0634X00	V116N605	KABBO105
DN 25	S16AA60600	5307	132	83	100	57.5	201	14	85	140	25	SGA0754X00	V116N606	KABBO106
DN 32	S16AA60700	7480	182	91	108	70	221	18	100	165	32	SGA0834X00	V116N607	KABBO107
DN 40	S16AA60800	9768	203	100	117	75	236	18	110	165	40	SGA0924X00	V116N608	KABBO108
DN 50	S16AA60900	13335	222	120	140	82.5	272	18	125	203	50	SNA1104X00	V116N609	KABBO109
DN 65	S16AA61000	22480	300	137	160	92.5	312.5	18	145	222	65	SNA1274X00	V116N610	KABBO110
DN 80	S16AA61100	27860	300	137	160	100	323.5	18	160	241	80	SNA1274X00	V116N611	KABBO011
DN 100	S16AA61200	44783	380	172	198	110	374.5	18	180	305	100	SNA1604X00	V116N612	KABBO012

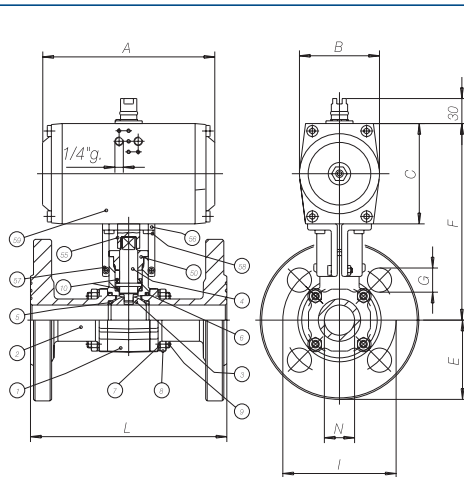

LIST OF VALVE COMPONENTS AND MATERIALS

REF.	PART	Qty	MATERIAL
1	BODY	1	CW617N (OT58)
2	FLANGE	2	CW617N (OT58)
3	BALL	1	CW614N (OT58)
4	STEM	1	CW614N (OT58)
5	SEAT	2	PTFE
6	FLANGE SEALING O-RING	2	VITON
7	WASHER	8	C72
8	NUT	8	4A
9	TIE ROD	4	8.8
10	UPPER SEALING COUPLE	2	PTFE
50	GLAND	1	CW614N (OT58)
55	ACTUATOR SHAFT	1	ALUMINIUM
56	BRACKET	1	ALUMINIUM
57	BRACKET/VALVE SCREW	2	8.8
58	BRACKET/ACTUATOR SCREW	4	8.8
59	ACTUATOR	1	

For accessories see relevant catalogue sheet

TRISTAR

3-WAY BALL VALVE—FULL BORE

MAIN STANDARD FEATURES

- CONSTRUCTION: AISI 316
- DIAMETER: from DN10 - 3/8" to DN 50 - 2"
- PRESSURES: from PN 40 to PN 25
- TEMPERATURE LIMITS: from -20°C to +160°C
- CONNECTIONS: F/F UNI-ISO 7/1 Rp - DIN 2999 parallel
- WRAPPING seats
- NON - WETTED parts in stainless steel
- OPERATION devices: lever handle
- TRIPLE stem-packing with labyrinth effect
- BALL: "L" bored
"T" bored
- 90° lever rotation clockwise



STANDARD PART NUMBERS

- Art. 2831** female/female with "L" bored ball
Art. 2851 female/female with "T" bored ball

SPECIAL EXECUTIONS

- Female connections: NPT ANSI B1.20.1
- 15% GLASS-FILLED PTFE. Temperature limits -20°C + 175°C
- PTFE+CARBOGRAPHITE: temperature limits -20°C + 195°C
- Degreased version
- ISO 5211 mounting plate for actuator
- Valve for pneumatic actuator
- Different flow combinations obtainable by removing the lever and rotating the stem in order to position the ball as requested during installation (the valve is supplied in the standard version)
- For further special requests please consult our technical/commercial service

GENERAL APPLICATIONS

Use as an ON-OFF valve for: diversion or mixing of fluids and gases in chemical plants, food, HEVAC and water plants. All parts have to be adequately degreased if the valves have to be used for oxygen. For special utilizations ascertain the compatibility with process features and the corrosion resistance also by the relevant table.

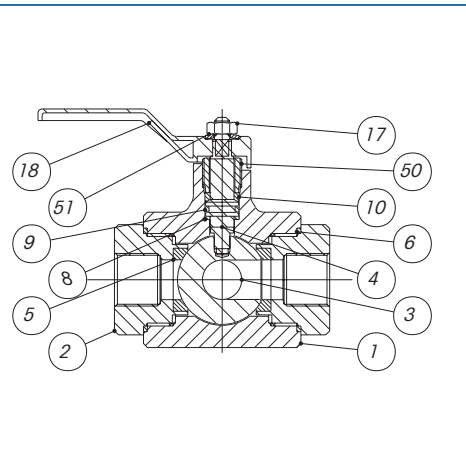

LIST OF COMPONENTS AND MATERIALS

REF.	PART	MATERIAL	DIN MAT.	QTY
1	BODY	AISI 316	1.4401	1
2	FEMALE END	AISI 316	1.4401	1
3	BALL	AISI 316	1.4401	1
4	STEM	AISI 316	1.4401	1
5	SEAT	PTFE	-	4
6	SIDE SEALING RING	PTFE	-	3
8	UPPER SEALING RING	PTFE	-	1
9	STEM O-RING	VITON	-	1
10	UPPER SEALING COUPLE	PTFE	-	1
17	LOCKING NUT	AISI 304	1.4301	1
18	LEVER HANDLE	AISI 304	1.4301	1
50	THREADED GLAND	AISI 303	1.4305	1
51	WASHER	AISI 304	1.4301	1

TRISTAR

3-WAY BALL VALVE—FULL BORE

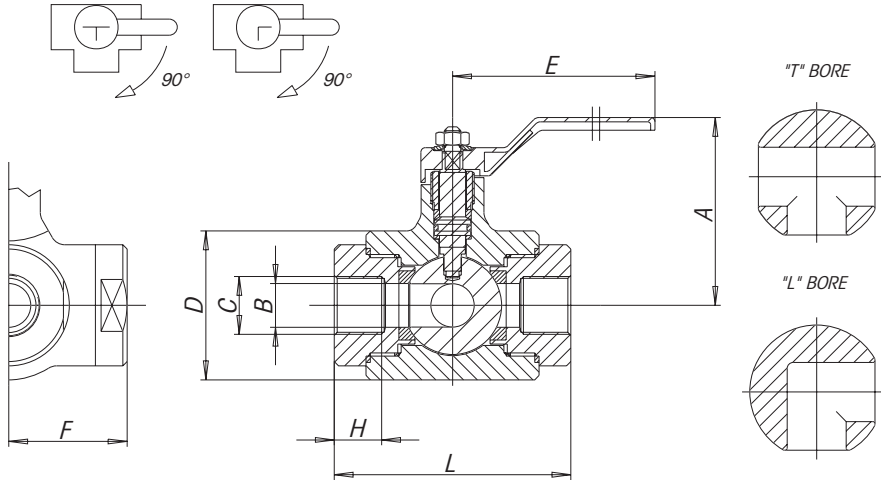

C (Inch)	A	B	D	E	F	H	L	weight in gr. FF
3/8"	77	12	45	126	36	-	72	1000
1/2"	82	15	52	126	41	15	82	1200
3/4"	85	20	60	148	46	16.3	92	1900
1"	95	25	70	148	51	19.1	102	2500
1 1/4"	115	32	85	180	59	21.4	118	4300
1 1/2"	130	40	100	180	67	21.4	134	6600
2"	140	50	110	185	72	25.7	144	8000

BREAKAWAY TORQUES in Nm

DN size	10	15	20	25	32	40	50
	3/8"	1/2"	3/4"	1"	1 1/4"	1 1/2"	2"
0	10	12	23	25	33	40	50
25	12.2	15.5	29.5	29	40.5	46	60
40	14	18	32.5	31	43	48	

PN - bar

Nm

The values in Nm may vary as a function of the seals material, temperature and type of medium. For a firm operation of the various types of actuators, in the different working conditions it is necessary to consider a safety factor of 1.5. During operation, with frequent open and close cycles, the operating torque can decrease considerably in comparison with the initial breakaway torque.

PRESSURE/TEMPERATURE DIAGRAM

At each pressure level corresponds the admissible temperature level.

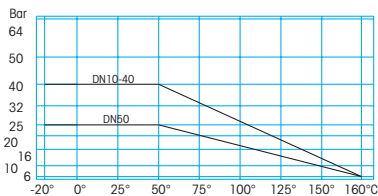

GEMINI

3-WAY BALL VALVE - "T" OR "L" BORE - REDUCED BORE

MAIN STANDARD FEATURES

- CONSTRUCTION: AISI 316
- DIAMETER: from DN8 - 1/4" to DN50 - 2"
- PRESSURES: PN 64 for all sizes
- TEMPERATURE LIMITS: from -20°C to +160°C
- CONNECTIONS: F/F UNI-ISO 7/1 Rp - DIN 2999 parallel
- NON-WETTED parts in stainless steel
- OPERATION device: lever handle
- ISO 5211 mounting plate for actuators
- BLOW-OUT PROOF stem from 1/4" to 2"
- BALL: "L" bored
"T" bored
- 90° lever rotation clockwise



STANDARD PART NUMBERS

Art. 2841

female/female with "T" bored ball

Art. 2846

female/female with "L" bored ball

SPECIAL EXECUTIONS

- Degreased version
- For further special requests please consult our technical/commercial service

GENERAL APPLICATIONS

Use as an ON-OFF valve for: diversion or mixing of fluids and gases in general installation.

For special utilizations ascertain the compatibility with process features and the corrosion resistance also by the relevant table.

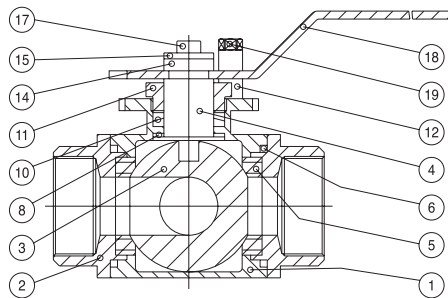

LIST OF COMPONENTS AND MATERIALS

REF.	PART	AISI 316 vers.	ASTM A105 vers.	Q.ty
1	BODY	AISI 316-CF8M	1.4401	1
2	FEMALE END	AISI 316-CF8M	1.4401	3
3	BALL	AISI 316	1.4401	1
4	STEM	AISI 316	1.4401	1
5	SEAT	PTFE		4
6	SIDE SEALING RING	PTFE		3
8	UPPER SEALING RING	PTFE		1
10	UPPER SEALING COUPLE	PTFE		1
11	GLAND	AISI 304	1.4301	1
12	OPERATION STOP	AISI 304	1.4301	1
14	STOP WASHER	AISI 304	1.4301	1
15	SCREW WASHER	AISI 304	1.4301	1
17	LOCKING NUT	AISI 304	1.4301	1
18	LEVER HANDLE	AISI 304	1.4301	1
19	OPERATION STOP SCREW	AISI 304	1.4301	1

GEMINI

3-WAY BALL VALVE - "T" OR "L" BORE - REDUCED BORE

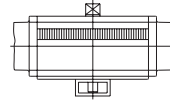
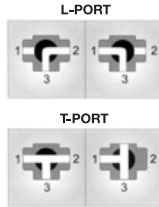
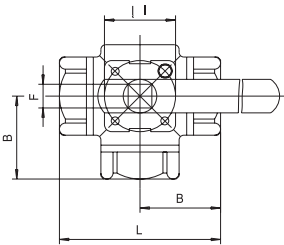
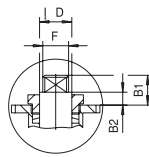
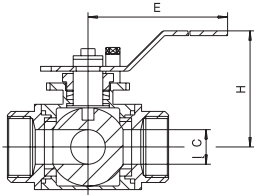

By removing the lever handle, the GEMINI valve can be assembled directly with an actuator by means of a bracket, the stem adapter (kit supplied on request) and by eliminating the operation stop (part. 12).

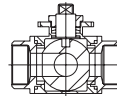

SIZE	B	B1	B2	Ø C	Ø D	E	F	H	Ø I	L	M	ISO 5211	Weight gr.
1/4"	34	11	6	11	12	106	9	58	42	68	M5	F04	600
3/8"	34	11	6	11	12	106	9	58	42	68	M5	F04	600
1/2"	37.5	11	6	12.7	12	138	9	61	42	75	M5	F04	700
3/4"	43	13	6	16	15	138	11	74	50	86	M6	F05	110
1"	51.5	19	7.5	20	15	162	11	81	50	103	M6	F05	1750
1 1/4"	57.5	19	7.5	25	15	162	11	88	50	115	M6	F05	2420
1 1/2"	62.5	23.5	8.5	32	15	220	11	104	70	125	M8	F07	3400
2"	73	24.5	8.5	38.1	18.5	220	14	110	70	146	M8	F07	5450

BREAKAWAY TORQUES in Nm

PN - bar	DIN size	8	10	15	20	25	32	40	50
	0	3.5	3.5	6	8	18	29	41	50
	64	7	7	9	11	23	38	54	64

Nm

The values in Nm may vary as a function of the seals material, temperature and type of medium. For a firm operation of the various types of actuators, in the different working conditions it is necessary to consider a safety factor of 1.5. During operation, with frequent open and close cycles, the operating torque can decrease considerably in comparison with the initial breakaway torque.

PRESSURE/TEMPERATURE DIAGRAM At each pressure level corresponds the admissible temperature level.

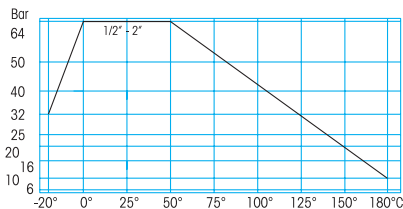

TRIFLUX

3-WAY BALL VALVE - "T" OR "L" PORT, REGULAR BORE,
WITH **DOUBLE ACTING** PNEUMATIC ACTUATOR

ACTUATOR FEATURES

- Rotation angle: 90°
- Standard version for temperature between -20°C and + 90°C
- Supply maximum pressure: 10 bar (8bar for DNA045)
- Nominal pressure: 5,62 bar
- Supply medium: dry filtered compressed air, not necessarily lubricated
- Lubrication: in such a case use a non-detergent or NBR compatible oil

STANDARD VALVE FEATURES

- Temperature limits: for fluids from -15°C to +100°C
- Working pressure: for fluids from 40 bar to 16 bar
- CONNECTION: F/F ISO 7/1 Rp - DIN2999 parallel
- Stem with double conical sealing by 4 seats
- For general applications and special versions see technical table of manual valve
- In the below table the part number and the valve code refer to the standard valve female/female, with T bored ball



SIZE	☑	Part Number	Weight in gr.	A	B	C	D	E	F	L	M	ACTUATOR code	VALVE code	MOUNTING KIT code
1/2"		D36AA20400	1170	110	53	68	38	13	147.5	80	21	DNA045AW00	V160N204	KABB0003
3/4"		D36AA20500	1974	127	59	74	48	18	161	96	26	DGA052AX00	V160N205	KABB0005
1"		D36AA20600	3192	133	70	88	58	23	189.5	113	31	DGA063AX00	V160N206	KABB0006
1 1/4"		D36AA20700	4540	132	83	100	67	29	213	130	34	DGA075AX00	V160N207	KABB0007
1 1/2"		D36AA20800	6510	182	91	108	78	35	227.5	147	40	DGA083AX00	V160N208	KABB0008
2"		D36AA20900	9566	203	100	117	95	44	249.5	169	47	DGA092AX00	V160N209	KABB0009

For the series with L -port the codes become: PART NUMBERS=D38AA20400 /. 20900, VALVE cod.=V161N204./209

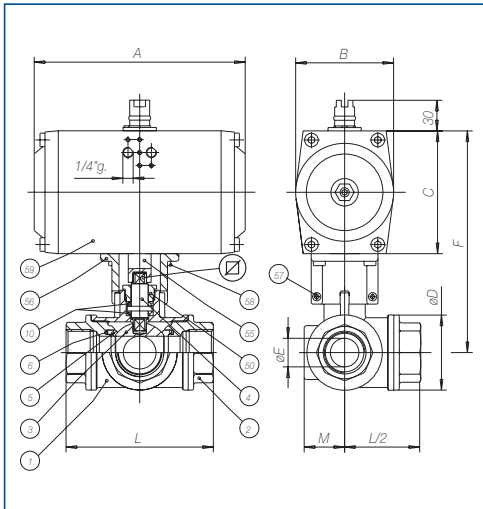

LIST OF VALVE COMPONENTS AND MATERIALS

REF.	PART	Qty	MATERIALE
1	BODY	1	CW617N (OT58)
2	FEMALE END	2	CW617N (OT58)
3	BALL	1	CW614N (OT58)
4	STEM	1	CW614N (OT58)
5	SEAT	2	PTFE
6	SIDE SEALING O-RING	2	VITON
10	UPPER SEALING COUPLE	2	PTFE
50	GLAND	1	CW614N (OT58)
55	ACTUATOR SHAFT	1	ALUMINIUM
56	BRACKET	1	ALUMINIUM
57	BRACKET/VALVE SCREW	2	8.8
58	BRACKET/ACTUATOR SCREW	4	8.8
59	ACTUATOR	1	

For accessories see relevant catalogue sheet

TRIFLUX

3-WAY BALL VALVE - "T" OR "L" PORT, REGULAR BORE,
WITH **DOUBLE ACTING** PNEUMATIC ACTUATOR

ACTUATOR FEATURES

- Rotation angle: 90°
- Standard version for temperature between -20°C and + 90°C
- Supply maximum pressure: 10 bar (8bar for DNA045)
- Nominal pressure: 5,62 bar
- Supply medium: dry filtered compressed air, not necessarily lubricated
- Lubrication: in such a case use a non-detergent or NBR compatible oil

STANDARD VALVE FEATURES

- Temperature limits: for fluids from -15°C to +100°C
- Working pressure: for fluids from 40 bar to 16 bar
- CONNECTION: F/F ISO 7/1 Rp - DIN2999 parallel
- Stem with double conical sealing by 4 seats
- For general applications and special versions see technical table of manual valve
- In the below table the part number and the valve code refer to the standard valve female/female, with T bored ball



SIZE	☑	Part Number	Weight in gr.	A	B	C	D	E	F	L	M	ACTUATOR code	VALVE code	MOUNTING KIT code
1/2"	7	S36AA20400	15665	127	59	74	38	13	153.5	80	21	SGA0524X00	V160N204	KABBO103
3/4"	10	S36AA20500	25800	133	70	80	48	18	185	96	26	SGA0634X00	V160N205	KABBO105
1"	10	S36AA20600	44900	182	91	108	58	23	211.5	113	31	SGA0834X00	V160N206	KABBO106
1 1/4"	14	S36AA20700	62400	203	100	117	67	29	235	130	34	SGA0924X00	V160N207	KABBO107
1 1/2"	14	S36AA20800	92000	203	100	117	78	35	262.5	147	40	SGA0924X00	V160N208	KABBO108
2"	17	S36AA20900	134600	294	120	140	95	44	272.5	169	47	SNA1184X00	V160N209	KABBO109

For the series with L -port the codes become: PART NUMBERS=S38AA20400 /. 20900, VALVE cod.=V161N204./,209

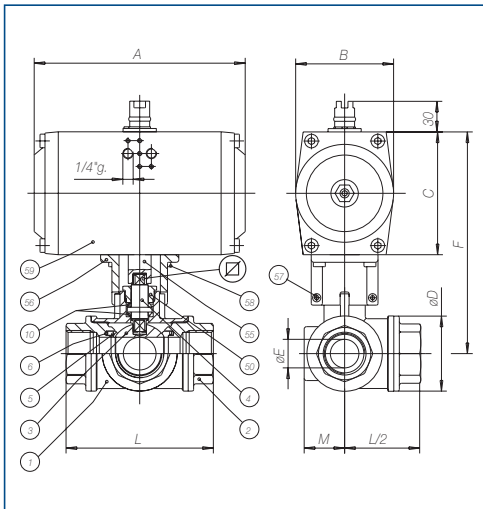

LIST OF VALVE COMPONENTS AND MATERIALS

REF.	PART	Qty	MATERIALE
1	BODY	1	CW617N (OT58)
2	FEMALE END	2	CW617N (OT58)
3	BALL	1	CW614N (OT58)
4	STEM	1	CW614N (OT58)
5	SEAT	2	PTFE
6	SIDE SEALING O-RING	2	VITON
10	UPPER SEALING COUPLE	2	PTFE
50	GLAND	1	CW614N (OT58)
55	ACTUATOR SHAFT	1	ALUMINIUM
56	BRACKET	1	ALUMINIUM
57	BRACKET/VALVE SCREW	2	8.8
58	BRACKET/ACTUATOR SCREW	4	8.8
59	ACTUATOR	1	

For accessories see relevant catalogue sheet

DELTA

3-WAY BALL VALVE - "L" PORT, FULL BORE,
WITH **DOUBLE ACTING** PNEUMATIC ACTUATOR

ACTUATOR FEATURES

- Rotation angle: 90°
- Standard version for temperature between -20°C and + 90°C
- Supply maximum pressure: 10 bar (8bar for DNA045)
- Nominal pressure: 5,62 bar
- Supply medium: dry filtered compressed air, not necessarily lubricated
- Lubrication: in such a case use a non-detergent or NBR compatible oil

STANDARD VALVE FEATURES

- Temperature limits: for fluids from -15°C to +120°C
- Working pressure: for fluids up to 10 bar maximum
- CONNECTION: F/F ISO 7/1 Rp - DIN2999 parallel
- Stem with double conical sealing by 4 seats
- For general applications and special versions see technical table of manual valve
- In the below table the part number and the valve code refer to the standard valve



SIZE	☑	Part Number	Weight in gr.	A	B	C	E	F	CH Oscipnat key	L	M	N	ACTUATOR code	VALVE code	MOUNTING KIT code
3/8"	7	D06AA20300	733	110	53	68	14.5	143.5	22	54	29	10	DNA045AW00	V151N203	KABBO003
1/2"	7	D06AA20400	894	110	53	68	18	146.5	27	69	36	14	DNA045AW00	V151N204	KABBO003
3/4"	10	D06AA20500	1035	110	53	66	22.5	153.5	23.5	77	45	19	DNA045AW00	V151N205	KABBO005
1"	10	D06AA20600	1737	127	59	74	27	175.5	40.5	89	54	24	DGA052AX00	V151N206	KABBO006
1 1/4"	14	D06AA20700	2860	133	70	88	32.5	202	50	103	65	30.5	DGA063AX00	V151N207	KABBO007
1 1/2"	14	D06AA20800	3588	133	70	88	39.5	210	55	114	79	38.5	DGA063AX00	V151N208	KABBO008
2"	17	D06AA20900	5635	132	83	100	48	230	70	134	96	48.5	DGA075AX00	V151N209	KABBO009

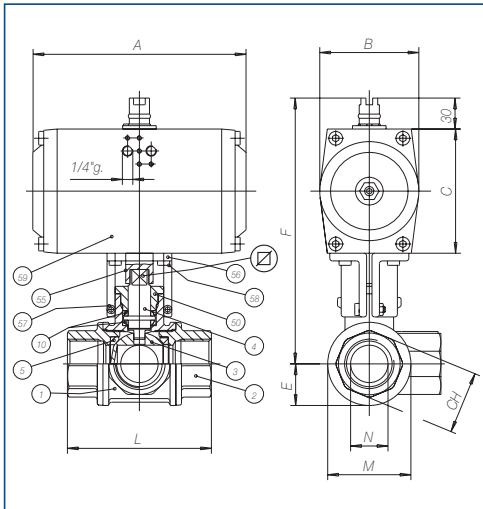

LIST OF VALVE COMPONENTS AND MATERIALS

REF.	PART	Qty	MATERIAL
1	BODY	1	CW617N (OT58)
2	FEMALE END	2	CW617N (OT58)
3	BALL	1	CW614N (OT58)
4	STEM	1	CW614N (OT58)
5	SEAT	2	PTFE
10	UPPER SEALING COUPLE	2	PTFE
50	SLAND	1	CW614N (OT58)
55	ACTUATOR SHAFT	1	ALUMINIUM
56	BRACKET	1	ALUMINIUM
57	BRACKET/VALVE SCREW	2	B.8
58	BRACKET/ACTUATOR SCREW	4	B.8
59	ACTUATOR	1	

For accessories see relevant catalogue sheet

DELTA

3-WAY BALL VALVE - "L" PORT, FULL BORE,
WITH SPRING RETURN PNEUMATIC ACTUATOR

ACTUATOR FEATURES

- Rotation angle: 90°
- Standard version for temperature between -20°C and + 90°C
- Supply maximum pressure: 10 bar
- Nominal pressure: 5,62 bar
- Supply medium: dry filtered compressed air, not necessarily lubricated
- Lubrication: in such a case use a non-detergent or NBR compatible oil
- STANDARD: SPRING CLOSES/AIR OPENS, clockwise automatic closing

STANDARD VALVE FEATURES

- Temperature limits: for fluids from -15°C to +120°C
- Working pressure: for fluids up to 10 bar maximum
- CONNECTION: F/F ISO 7/1 Rp - DIN2999 parallel
- Stem with double conical sealing by 4 seals
- For general applications and special versions see technical table of manual valve
- In the below table the part number and the valve code refer to the standard valve



SIZE	□	Part Number	Weight in gr.	A	B	C	D	E	F	CH Octagonal key	L	M	N	ACTUATOR code	VALVE code	MOUNTING KIT code
3/8"	7	S06AA20300	1173	127	59	74	30	14.5	150	22	54	29	10	SGA0523X00	V151N203	KABBO103
1/2"	7	S06AA20400	1329	127	59	74	30	18	152.5	27	69	36	14	SGA0523X00	V151N204	KABBO103
3/4"	10	S06AA20500	2115	133	70	88	30	22.5	173.5	23.5	77	45	19	SGA0634X00	V151N205	KABBO105
1"	10	S06AA20600	3257	132	83	100	30	27	201.5	40.5	89	54	24	SGA0754X00	V151N206	KABBO106
1 1/4"	14	S06AA20700	4420	182	91	108	30	32.5	222	50	103	65	30.5	SGA0834X00	V151N207	KABBO107
1 1/2"	14	S06AA20800	6118	203	100	117	30	39.5	237.5	55	114	79	38.5	SGA0924X00	V151N208	KABBO108
2"	17	S06AA20900	8635	222	120	140	30	48	273.5	70	134	96	48.5	SN1104X00	V151N209	KABBO109

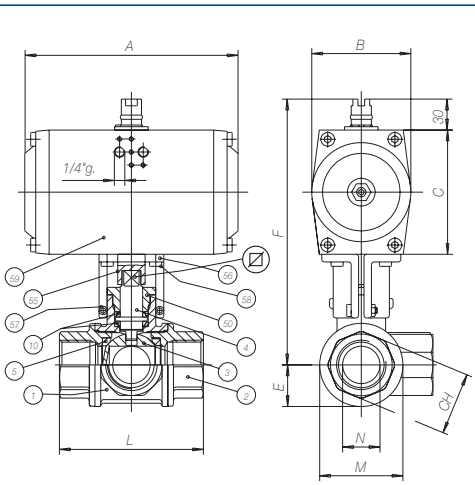

LIST OF VALVE COMPONENTS AND MATERIALS

REF.	PART	Qty	MATERIAL
1	BODY	1	CW617N (OT58)
2	FEMALE END	2	CW617N (OT58)
3	BALL	1	CW614N (OT58)
4	STEM	1	CW614N (OT58)
5	SEAT	2	PTFE
10	UPPER SEALING COUPLE	2	PTFE
50	GLAND	1	CW614N (OT58)
55	ACTUATOR SHAFT	1	ALUMINIUM
56	BRACKET	1	ALUMINIUM
57	BRACKET/VALVE SCREW	2	8.8
58	BRACKET/ACTUATOR SCREW	4	8.8
59	ACTUATOR	1	

For accessories see relevant catalogue sheet

TOTAL STEELBALL

2-PIECE BALL VALVE—FULL BORE

MAIN STANDARD FEATURES

- CONSTRUCTION: BODY CW617N (OT58), BALL AISI 316
- DIAMETER: from DN10 - 3/8" to DN 50 - 2"
- PRESSURES: from 64 bar to 32 bar for fluids and PN 4 for gas
- TEMPERATURE LIMITS: from -20°C to +150°C for fluids
from -20°C to +60°C for gas
- CONNECTIONS: F/F UNI-ISO 7/1 Rp – DIN 2999 parallel
- WRAPPING seats
- DOUBLE stem-packing with 4 conical seats
- OPERATION devices: lever or T-handle

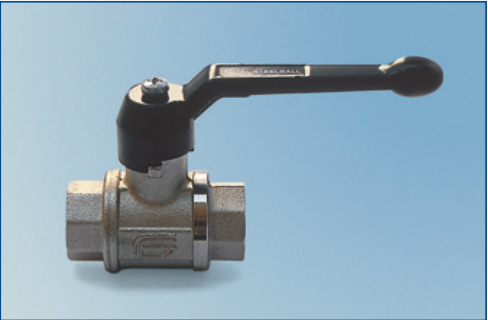

STANDARD PART NUMBERS

Art. 2990
female/female w/lever

Art. 2995
female/female w/T-handle up to 1"

SPECIAL EXECUTIONS

- Yellow lever handle for gas
- Stem extension
- Square cap
- Sealing cap
- Underground adaptor
- On request the valve is available with ATEX certificate
- For further special requests please consult our technical/commercial service

GENERAL APPLICATIONS

Use as an ON-OFF valve for: general industrial applications, for water, vacuum, gas distribution, industrial heating, for partially corrosive media and for steam.

For special utilizations ascertain the compatibility with process features and the corrosion resistance also by the relevant table.

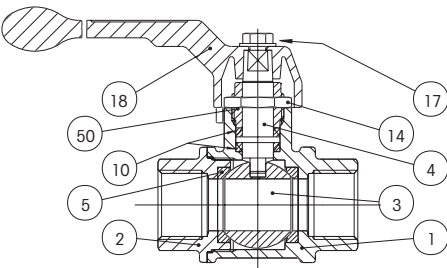

LIST OF COMPONENTS AND MATERIALS

REF.	PART	MATERIAL	UNI/DIN MAT.	QTY
1	BODY	CW617N (OT58)	UNI5705-65	1
2	FEMALE END	CW617N (OT58)	UNI5705-65	1
3	BALL	AISI 316	1.4401	1
4	STEM	CW614N (OT58)	UNI5705-65	1
5	SEAT	PTFE		2
10	UPPER SEALING COUPLE	PTFE		2
14	GLAND NUT	CW614N (OT58)	UNI5705-65	1
17	FIXING SCREW	zinc plated steel		1
18	LEVER HANDLE	see below	UNI5706	1
50	GLAND	CW614N (OT58)	UNI5705-65	1
	SURFACE TREATMENT	brilliant nickel-plating		
	SEALANT	loctite AVX 586		

LEVER: ALUM. ALLOY POLYUR. COATED

TOTAL STEELBALL

2-PIECE BALL VALVE—FULL BORE

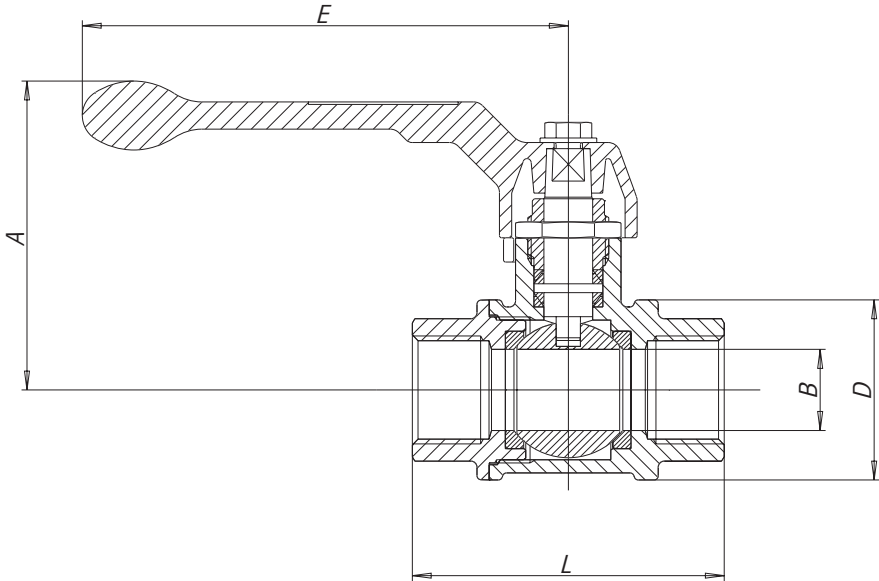

SIZE	A	B	D	E	L	Weight in gr
3/8"	61	10	29	100	54	240
1/2"	64	15	36	100	69	370
3/4"	76	20	45	120	77	630
1"	80	25	54	120	89	900
1 1/4"	97	32	65	150	103	1570
1 1/2"	104	40	79	150	114	2380
2"	118	50	96	175	134	3770

PRESSURE/TEMPERATURE DIAGRAM

At each pressure level corresponds the admissible temperature level.

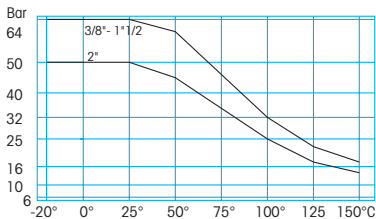

LOSS OF HEAD DIAGRAM/FLOW RATE

The Kv value is the flow rate causing a pressure drop of 1 bar

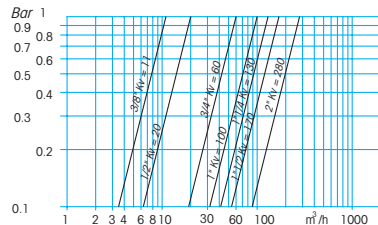

TOTAL

2-PIECE BALL VALVE - FULL BORE WITH DOUBLE ACTING PNEUMATIC ACTUATOR

ACTUATOR FEATURES

- Rotation angle: 90°
- Standard version for temperature between -20°C and + 90°C
- Supply maximum pressure: 10 bar (8bar for DNA045)
- Nominal pressure: 5,62 bar
- Supply medium: dry filtered compressed air, not necessarily lubricated
- Lubrication: in such a case use a non-detergent or NBR compatible oil

STANDARD VALVE FEATURES

- Working temperature: from -20°C to +150°C for fluids
from -20°C to + 60°C for gas
- Working pressure: from 64 bar to 20 bar for fluids.
PN 4 for gas.
- CONNECTIONS: F/F UNI-ISO 7/1 Rp – DIN 2999 parallel
- DOUBLE stem-packing with 4 conical seals
- For general applications and special versions see technical table of manual valve
- In the below table the part number and the valve code refer to the standard valve female/female



SIZE	☑	PART NUMBER	weight in gr.	A	B	C	E	F	GH coding	L	M	N	ACTUATOR code	ACTUATOR code	MOUNTING KIT code
3/8"	☑	D11AA20300	730	110	53	68	14.5	143.5	22	54	29	10	DNA045AW00	V111N203	KABBO003
1/2"	☑	D11AA20400	865	110	53	68	18	146.5	27	69	36	15	DNA045AW00	V111N204	KABBO003
3/4"		D11AA20500	1030	110	53	68	22.5	153.5	23.5	77	45	20	DNA045AW00	V111N205	KABBO005
1"		D11AA20600	1690	127	59	74	27	175.5	40.5	89	54	25	DGA052AX00	V111N206	KABBO006
1 1/4"		D11AA20700	2805	133	70	88	32.5	202	50	103	65	32	DGA063AX00	V111N207	KABBO007
1 1/2"		D11AA20800	3630	133	70	88	39.5	210	55	114	79	40	DGA063AX00	V111N208	KABBO008
2"		D11AA20900	5665	132	83	100	48	230	70	134	96	50	DGA075AX00	V111N209	KABBO009
2 1/2"		D11AA21000	8470	203	100	117	59.5	269	86	161	119	65	DGA092AX00	V111N210	KABBO010
3"		D11AA21100	14465	222	120	140	72	303	100	185	144	80	DNA110AX00	V111N211	KABBO011

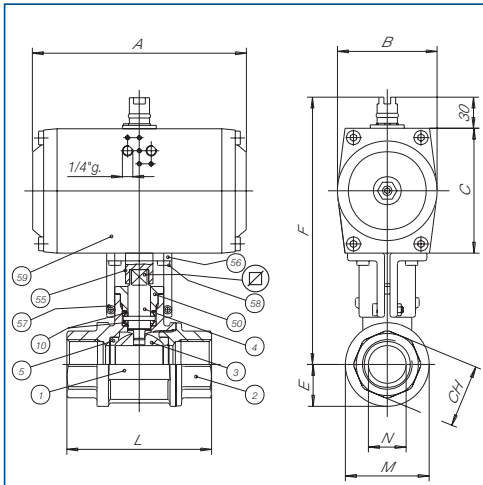

LIST OF VALVE COMPONENTS AND MATERIALS

REF.	PART	QTY	MATERIAL
1	BODY	1	CW617N (OT58)
2	FEMALE END	1	CW617N (OT58)
3	BALL	1	CW614N (OT58)
4	STEM	1	CW614N (OT58)
5	SEAT	2	PTFE
10	UPPER SEALING COUPLE	2	PTFE
50	SLAND	1	CW614N (OT58)
55	ACTUATOR SHAFT	1	ALUMINIUM
56	BRACKET	1	ALUMINIUM
57	BRACKET/VALVE SCREW	2	8.8
58	BRACKET/ACTUATOR SCREW	4	8.8
59	ACTUATOR	1	

For accessories see relevant catalogue sheet

TOTAL

2-PIECE BALL VALVE - FULL BORE WITH **SPRING RETURN** PNEUMATIC ACTUATOR

ACTUATOR FEATURES

- Rotation angle: 90°
- Standard version for temperature between -20°C and + 90°C
- Supply maximum pressure: 10 bar
- Nominal pressure: 5,62 bar
- Supply medium: dry filtered compressed air, not necessarily lubricated
- Lubrication: in such a case use a non-detergent or NBR compatible oil
- STANDARD: **SPRING CLOSES/AIR OPENS**, clockwise automatic closing

STANDARD VALVE FEATURES

- Working temperature: from -20°C to +150°C for fluids
from -20°C to + 60°C for gas
- Working pressure: from 64 bar to 20 bar for fluids. PN 4 for gas.
- CONNECTIONS: F/F UNI-ISO 7/1 Rp – DIN 2999 parallel
- DOUBLE stem-packing with 4 conical seals
- For general applications and special versions see technical table of manual valve
- In the below table the part number and the valve code refer to the standard valve female/female



SIZE	☑	PART NUMBER	weight in gr.	A	B	C	E	F	GH coding	L	M	N	ACTUATOR code	ACTUATOR code	MOUNTING KIT code
3/8"	7	S11AA20300	1170	127	59	74	14.5	150	22	54	29	10	SGA0523X00	V111N203	KABBO103
1/2"	7	S11AA20400	1300	127	59	74	18	152.5	27	69	36	15	SGA0523X00	V111N204	KABBO103
3/4"	10	S11AA20500	2110	133	70	88	22.5	173.5	23.5	77	45	20	SGA0634X00	V111N205	KABBO105
1"	10	S11AA20600	3210	132	83	100	27	201.5	40.5	89	54	25	SGA0754X00	V111N206	KABBO106
1 1/4"	14	S11AA20700	4365	182	91	108	32.5	222	50	103	65	32	SGA0834X00	V111N207	KABBO107
1 1/2"	14	S11AA20800	6160	203	100	117	39.5	237.5	55	114	79	40	SGA0924X00	V111N208	KABBO108
2"	17	S11AA20900	8665	222	120	140	48	273.5	70	134	96	50	SGA1104X00	V111N209	KABBO109
2 1/2"	22	S11AA21000	15380	300	137	160	59.5	311.5	86	161	119	65	SGA1274X00	V111N210	KABBO110
3"	22	S11AA21100	19780	300	137	160	72	323	100	185	144	80	SGA1274X00	V111N211	KABBO111

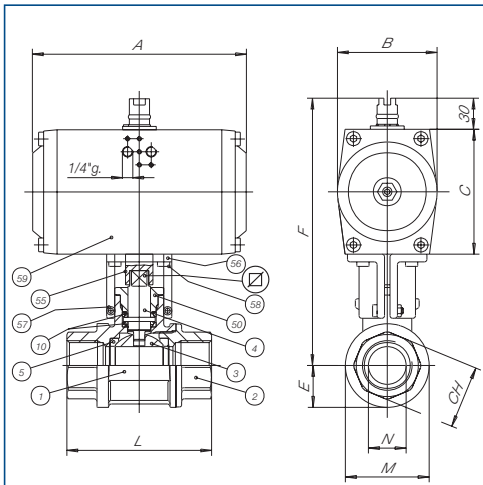

LIST OF VALVE COMPONENTS AND MATERIALS

REF.	PART	QTY	MATERIAL
1	BODY	1	CW617N (OT58)
2	FEMALE END	1	CW617N (OT58)
3	BALL	1	CW614N (OT58)
4	STEM	1	CW614N (OT58)
5	SEAT	2	PTFE
10	UPPER SEALING COUPLE	2	PTFE
50	GLAND	1	CW614N (OT58)
55	ACTUATOR SHAFT	1	ALUMINIUM
56	BRACKET	1	ALUMINIUM
57	BRACKET/VALVE SCREW	2	8.8
58	BRACKET/ACTUATOR SCREW	4	8.8
59	ACTUATOR	1	

For accessories see relevant catalogue sheet

PNEUMATIC ACTUATOR

DEVICE FOR AUTOMATIC VALVE OPERATION BY COMPRESSED AIR, DOUBLE ACTING OR SPRING RETURN

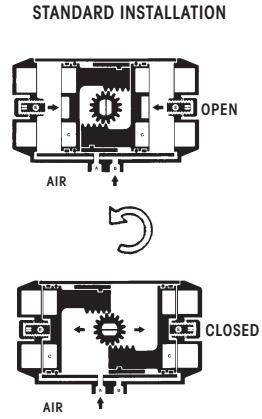
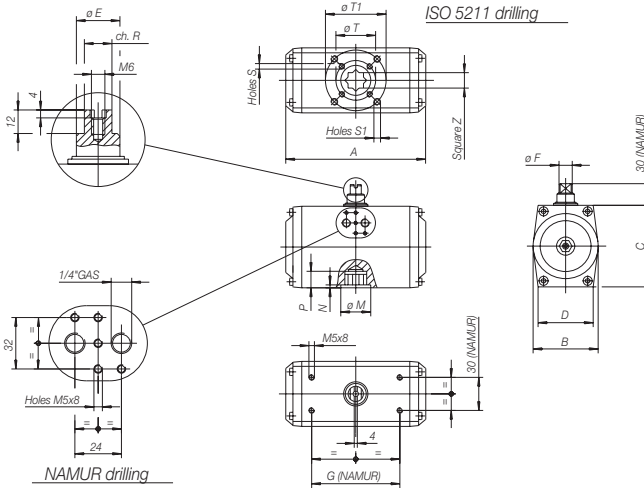

IT IS AVAILABLE A SPECIAL EXECUTION D.E. OPERATED BY WATER

SIZE	A	B	C	D	øE	øF	G	øM	N	P	ch. R	Holes S	øT	Holes S1	øT1	Square Z	Weight gr. DE	Weight gr. SE *	N°	Sec
045	110	65	68	53	12	12	80	25/30	2	14	9	M5x11	36 (ISO F03)	M5x11	42 (ISO F05)	9/11	500	600		
052	127	59	74	50	12	12	80	23.8	2	18	10	M5x8	36 (ISO F03)	M6x10	50 (ISO F05)	14	800	950	0,25	0,158
063	133	70	88	60	12	12	80	23.8	2	18	10	M6x10	50 (ISO F05)	M8x13	70 (ISO F07)	14	1.350	1.500	0,40	0,214
075	132	83	100	65	18	14	80	29.3	2	19	10	M6x10	50 (ISO F05)	M8x13	70 (ISO F07)	17	1.950	2.200	0,60	0,334
083	182	91	108	65	18	14	80	32.3	2	19	10	M6x10	50 (ISO F05)	M8x13	70 (ISO F07)	17	2.500	2.800	0,82	0,430
092	203	100	117	70	25	19.5	80	37.3	2	19	14	M6x10	50 (ISO F05)	M8x13	70 (ISO F07)	17	3.350	3.650	1,20	0,444
110	222	120	140	90	25	19.5	80	37.3	2.5	24.5	14	M8x13	70 (ISO F07)	M10x16	102 (ISO F10)	22	4.800	5.500	1,90	0,462
118	294	120	140	90	40	28	80	53.3	2.5	24.5	20	M8x13	70 (ISO F07)	M10x16	102 (ISO F10)	22	6.800	7.700	2,30	0,600
127	300	137	160	103	40	28	80	53.3	3	25	20	M8x13	70 (ISO F07)	M10x16	102 (ISO F10)	22	8.500	9.650	3,65	0,858
160	380	172	198	110	40	36	130	66.3	3	29	28	M10x16	102 (ISO F10)	M12x20	125 (ISO F12)	27	15.600	18.150	4,00	1,620
210	450	224	255	135	60	47	130	79.3	4	40	32	-	-	M16x25	140 (ISO F14)	36	31.200	36.600	15,22	3,330
254	603	272	302	159	60	47	130	105.3	4	50	32	-	-	M20x28	165 (ISO F16)	46	60.000	74.700	22,00	6,000
255	683	272	302	159	60	47	130	134	3.1	50	32	-	-	M20x28	165 (ISO F16)	46	73.000	87.700	32,00	7,500

DOUBLE ACTING ACTUATOR:

In the case of double acting actuator it is sufficient to look at the below table for a needed torque value, increased by 10% for an acceptable safety factor. The coordinates of relevant case show the type of DE actuator and the necessary working pressure in kPa.

EXAMPLE: if you have to operate a valve requiring a torque of 200 Nm, you apply 10% safety factor and obtain 220 Nm. You then choose DNA 127x90 giving a torque of 275 Nm at 500 kPa., or DNA 118x90, giving a torque of 252 Nm at 600 kPa.

TIPO	100 kPa	200 kPa	300 kPa	400 kPa	500 kPa	562 kPa	600 kPa	700 kPa	800 kPa	900 kPa	1000 kPa
DNA045	2.3	4.6	6.9	9.2	11.5	12.9	13.8	16.1	18.4	-	-
DGA052	3.9	7.8	11.7	15.6	19.5	21.9	23.4	27.3	31.2	35.1	39.0
DGA063	5.8	11.6	17.4	23.2	29.0	32.6	34.8	40.6	46.4	52.2	58.0
DGA075	10.0	20.0	30.0	40.0	50.0	56.2	60.0	70.0	80.0	90.0	100.0
DGA083	14.0	28.0	42.0	56.0	70.0	78.7	84.0	98.0	112.0	126.0	140.0
DGA092	19.4	38.8	58.2	77.6	97.0	109.0	116.4	135.8	155.2	174.6	194.0
DNA110	28.2	56.4	84.6	112.8	141.0	158.5	169.2	197.4	225.6	253.8	282.0
DNA118	42.0	84.0	126.0	168.0	210.0	236.0	252.0	294.0	336.0	378.0	420.0
DNA127	55.0	110.0	165.0	220.0	275.0	309.1	320.0	385.0	440.0	495.0	550.0
DNA160	110.0	220.0	330.0	440.0	550.0	618.0	660.0	770.0	880.0	990.0	1100
DNA210	237.0	474.0	711.0	948.0	1185	1332	1422	1659	1896	2133	2370
DNA254	435.0	870.0	1305	1740	2175	2445	2610	3045	3480	3915	4350
DNA255	543.0	1086	1629	2172	2715	3051	3258	3801	4344	4887	5430

PNEUMATIC ACTUATOR

BREAKAWAY TORQUES GIVEN BY THE ACTUATOR AT A DIFFERENT PRESSURE
DEVICE FOR AUTOMATIC VALVE OPERATION BY COMPRESSED AIR, ACTING OR SPRING RETURN

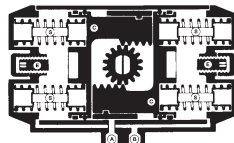

CLOSED

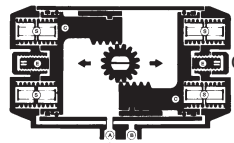

OPEN

SPRINGS ACTION

AIR ↑

• VALUES EXPRESSED IN Nm

• 0° STRETCHED SPRING

• 90° COMPRESSED SPRING

TIPO/TYPE	STRESS RELIEVED SPRING		TOTAL NR ACTUATOR SPRING	2 BAR		3 BAR		4 BAR		5 BAR		5.6 BAR		6 BAR		7 BAR		8 BAR		9 BAR		10 BAR		
	0°	90°		N°	0°	90°	0°	90°	0°	90°	0°	90°	0°	90°	0°	90°	0°	90°	0°	90°	0°	90°		
	045	2.9 4.4 5.9		5.0 7.5 10	4 6 8			4.0	1.9	6.3 4.8 1.6	4.2 1.6	8.7 6.6 5.6	10.1 8.0 5.4	8.0 5.5 2.8	11.0 9.5 6.3	8.9 6.3 3.8	11.0 10.8 11.8	11.2 8.7 6.1	15.7 14.1 11.0	13.6 13.3 16.5	18.0 15.6 10.8	15.9 13.3 10.8	20.3 18.8 17.3	18.2 15.7 13.1
052	3.7 5.5 7.4 9.3 11.1	6.3 9.4 12.6 15.7 18.9	4 6 8 10 12	4.0	1.4	7.9 6.0	5.3 2.1	11.8 9.8 8.0 2.7	4.8 3.9 2.7	15.7 13.8 11.9 10.0 8.1	15.7 13.1 11.6 12.2	16.1 14.2 12.0	18.0 15.8 13.9	15.4 10.5 7.8	17.7 15.7 13.7	21.6 19.4 17.2	23.5 20.9 18.7	20.9 17.4 15.2	27.4 24.8 21.7	24.8 21.6 19.1	31.3 28.4 25.6	29.2 26.2 23.7	35.2 33.3 31.5	
063	4.9 8.8 11.7 14.7 17.9	8.3 13.3 17.7 22.2 26.6	4 6 8 10 12	5.6	2.5	11.4 8.4	8.3 3.8	17.2 14.2 11.2 5.1	14.1 9.6 6.3	23.0 20.0 17.0 14.0	19.9 15.4 10.9	28.5 23.5 18.9	27.4 22.8 17.5	40.1 35.1 30.2	34.9 31.4 27.9	50.1 45.1 40.2	44.9 41.2 37.5	60.1 55.1 50.2	54.9 51.4 47.8	70.1 65.1 60.2	64.9 61.4 57.8	80.1 75.1 70.2	74.9 70.1 65.2	89.9 84.9 79.9
075	14.5 19.4 24.2 29.1	22.1 29.5 36.9 44.2	4 6 8 10	10.1	4.9	20.1 15.1	14.9 7.4	30.1 25.1 20.2 15.2	24.9 17.4 12.4	40.1 35.1 30.2 25.2	34.9 31.4 27.9 24.4	46.1 41.1 36.2 31.2	40.9 35.9 30.9 25.9	55.1 50.1 45.1 40.2	49.9 44.9 39.9 34.9	64.9 59.9 54.9 49.9	59.1 54.1 49.1 44.1	74.9 69.9 64.9 59.9	69.9 64.9 59.9 54.9	84.9 79.9 74.9 69.9	79.9 74.9 69.9 64.9	89.9 84.9 79.9 74.9		
083	24.2 31.3 38.3 45.3 52.3	21.5 32.3 43.1 53.9 64.7	4 6 8 10 12	14.5	7.0	29.0 21.7	21.5 10.5	43.0 36.5 30.0 23.5	25.0 20.0 15.0	58.0 50.5 43.0 35.5	50.5 39.5 28.5 21.0	66.7 59.2 51.7 44.2	58.2 50.7 43.2 35.7	75.2 67.7 60.2 52.7	67.7 60.2 52.7 45.2	85.0 77.5 70.0 62.5	77.5 70.0 62.5 55.0	94.2 86.7 79.2 71.7	86.7 79.2 71.7 64.2	104.0 96.5 89.0 81.5	96.5 89.0 81.5 74.0	116.0 108.5 101.0 93.5	108.5 101.0 93.5 86.0	123.0 115.5 108.0 100.5
092	18.2 27.3 36.4 45.5 54.6	28.6 43.0 57.3 71.7 86.0	4 6 8 10 12	21.4	10.7	41.4 32.2	30.8 16.1	61.5 52.2 43.0 33.8	60.8 51.6 42.4 33.2	81.5 72.2 63.0 53.8	70.8 61.6 52.4 43.2	93.5 84.2 75.0 65.8	82.8 73.6 64.4 55.2	102.0 92.7 83.5 74.3	90.8 81.5 72.3 63.0	122.0 112.7 103.4 94.1	122.0 112.7 103.4 94.1	152.0 142.7 133.4 124.1	152.0 142.7 133.4 124.1	182.0 172.7 163.4 154.1	182.0 172.7 163.4 154.1	212.0 202.7 193.4 184.1	212.0 202.7 193.4 184.1	
110	30.1 45.2 60.3 75.4 90.5	46.8 70.3 93.7 117.0 140.0	4 6 8 10 12	27.2	10.2	56.2 40.8	39.2 15.3	85.2 69.8 54.4	68.2 52.8 37.4	114.0 97.2 80.4	97.2 80.4 63.6	132.0 116.0 100.0	116.0 100.0 84.0	148.0 132.0 116.0	132.0 116.0 100.0	182.0 166.0 150.0	166.0 150.0 134.0	212.0 196.0 180.0	196.0 180.0 164.0	238.0 222.0 206.0	222.0 206.0 190.0	258.0 242.0 226.0	242.0 226.0 210.0	282.0 266.0 250.0
118	44.8 67.2 89.6 112.0 134.4	73.6 110.0 147.0 184.0 220.0	4 6 8 10 12	40.6	10.9	83.3 60.4	53.9 16.4	126.0 109.6 93.2	96.9 80.5 64.0	169.0 146.0 123.0	146.0 123.0 100.0	195.0 172.0 149.0	172.0 149.0 126.0	212.0 189.0 166.0	189.0 166.0 143.0	238.0 215.0 192.0	215.0 192.0 169.0	282.0 266.0 250.0	266.0 250.0 234.0	312.0 296.0 280.0	296.0 280.0 264.0	342.0 326.0 310.0	326.0 310.0 294.0	
127	97.0 129 161 194	148 197 247 296	4 6 8 10	50.0	15.2	108 75.0	73.2 22.8	166 131 100	131 100 70.0	224 189 158	189 158 125	259 224 193	224 193 162	282 247 212	247 212 177	342 307 272	307 272 237	378.0 343.0 308.0	343.0 308.0 273.0	426.0 391.0 356.0	391.0 356.0 321.0	474.0 439.0 404.0	439.0 404.0 369.0	512.0 477.0 442.0
143	93.9 140 234 381	129 194 259 324 389	4 6 8 10 12	90.2	53.7	183 135	147 80.5	276 228 180 133	228 174 120 65.2	369 333 297 261	333 297 261 225	426 391 356 321	391 356 321 286	474.0 439.0 404.0 369.0	439.0 404.0 369.0 334.0	512.0 477.0 442.0 407.0	477.0 442.0 407.0 372.0	556.0 521.0 486.0 451.0	521.0 486.0 451.0 416.0	604.0 569.0 534.0 499.0	569.0 534.0 499.0 464.0	642.0 607.0 572.0 537.0		
160	109 183 218	148 242 323 403	4 6 8 10	118	63.6	233 177	179 95.4	348 294 240	294 240 179	492 407 321	407 321 236	522 447 372	447 372 297	560 485 410	485 410 335	604 529 454	529 454 379	642.0 607.0 572.0	607.0 572.0 537.0	678.0 643.0 608.0	643.0 608.0 573.0	724.0 689.0 654.0	689.0 654.0 619.0	802.0 767.0 732.0
190	198 297 396 496 595	285 398 531 663 798	4 6 8 10 12	196	127	396 293 191	327 52.9	596 520 391	520 391 253	796 693 583	693 583 473	916 813 711	813 711 609	1036 933 830	933 830 727	1136 1033 930	1033 930 827	1236 1133 1030	1133 1030 927	1336 1233 1130	1233 1130 1027	1436 1333 1230	1333 1230 1127	1536 1433 1330
210	219 328 438 547 657	318 478 637 796 956	4 6 8 10 12	254	152	494 382 269	322 128 63.5	632 482 336	482 336 190	872 708 543	708 543 379	1118 1005 893	1016 893 779	1214 1101 989	1101 989 877	1454 1341 1229	1341 1229 1116	1694 1601 1489	1601 1489 1378	1894 1801 1709	1801 1709 1617	2174 2071 1943	2071 1943 1830	2472 2369 2266
254	442 648 1080 1296	633 950 1585 1902	4 6 8 10	475	267	935 713	727 101	1855 1361 950 528	1647 1153 740 319	2638 2145 1652 1159	2145 1652 1159 667	2786 2393 1900 1407	2393 1900 1407 914	3026 2633 2240 1847	2633 2240 1847 1454	3266 2873 2480 2087	2873 2480 2087 1694	3512 3119 2726 2333	3119 2726 2333 1940	3748 3355 2962 2569	3355 2962 2569 2176	4393 3999 3606 3213	3999 3606 3213 2820	4598 4204 3811 3418
255	471 707 943 1178 1414	836 1255 1673 2091 2510	4 6 8 10 12	1114	738	1914 1429 1186	1538 977 726	2415 1849 1283	1849 1283 726	2938 2372 1806	2372 1806 1240	3394 2828 2262	2828 2262 1696	3809 3243 2677	3243 2677 2111	3678 3112 2546	3112 2546 1980	4038 3472 2906	3472 2906 2340	4398 3832 3266	3832 3266 2700	4753 4187 3621	4187 3621 3055	4598 4032 3466
300	941 1178 1414	837 1255 1673 2091 2510	4 6 8 10 12	1114	738	1914 1429 1186	1538 977 726	2415 1849 1283	1849 1283 726	2938 2372 1806	2372 1806 1240	3394 2828 2262	2828 2262 1696	3809 3243 2677	3243 2677 2111	3678 3112 2546	3112 2546 1980	4038 3472 2906	3472 2906 2340	4398 3832 3266	3832 3266 2700	4753 4187 3621	4187 3621 3055	4598 4032 3466

SPARE PARTS

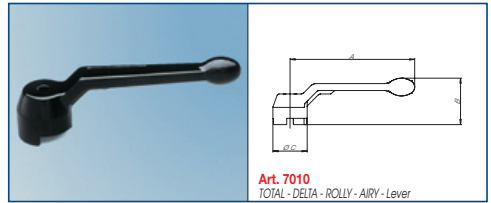
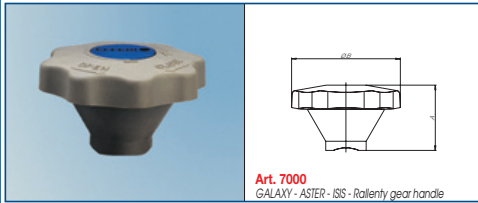

GALAXY	1/4"-1"	1 1/4"-2"					
ASTER	3/8"-1"	1 1/4"-2"					
ISIS	1/4"-1"	1 1/4"-2"					
Amm	50	78					
ØBmm	83	130					

TOTAL	1/8"-1/4"	3/8"-1/2"	3/4"-1"	1 1/4"-1 1/2"	2"	2 1/2"-3"	
DELTA		1/4"-1/2"	3/4"-1"	1 1/4"-1 1/2"	2"		
ROLLY		DN 15	DN 20-25	DN 32-40	DN 50	DN 65-80	
AIRY		1/8"-1/2"	3/4"-1"	1 1/4"-1 1/2"	2"		
Amm	75	100	120	150	175	280	
Bmm	34	39	45	51	56	74	
ØCmm	24	29	33	43	48	66	

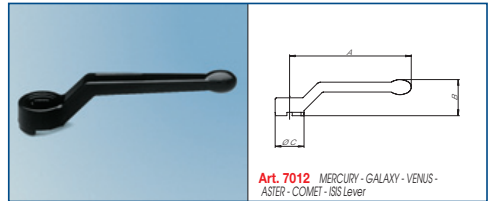
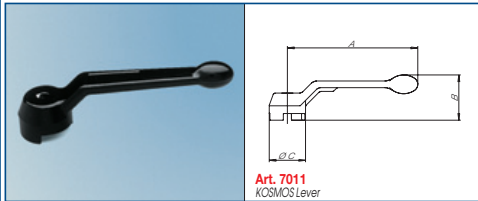

KOSMOS	1/8"-1/4"	3/8"	1/2"-3/4"	1"	1 1/4"-1 1/2"	2"	2 1/2"-3"
Amm							
Bmm							
ØCmm							
	TOTAL 1/8"-1/4"	TOTAL 3/8"-1/2"	TOTAL 3/8"-1/2"	TOTAL 3/4"-1"	TOTAL 1 1/4"-1 1/2"	TOTAL 2"	TOTAL 2 1/2"-3"

MERCURY	1/4"-1/2"	3/4"-1"	1 1/4"-1 1/2"	2"	2 1/2"-4"		
GALAXY	1/4"-1/2"	3/4"-1"	1 1/4"-1 1/2"	2"	2 1/2"-4"		
VENUS	1/4"-1/2"	3/4"-1"	1 1/4"-1 1/2"	2"	2 1/2"-4"		
ASTER	1/4"-1/2"	3/4"-1"	1 1/4"-1 1/2"	2"	2 1/2"-4"		
COMET	1/4"-1/2"	3/4"-1"	1 1/4"-1 1/2"	2"	2 1/2"-4"		
ISIS	1/4"-1/2"	3/4"-1"	1 1/4"-1 1/2"	2"			
Amm	85	105	130	165	260		
Bmm	27	32	39	47	57		
ØCmm	22	25	32	37	47		

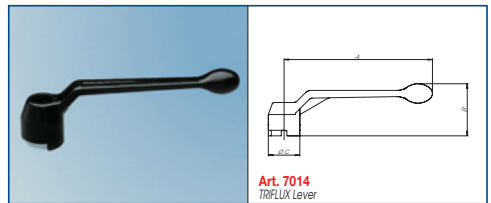
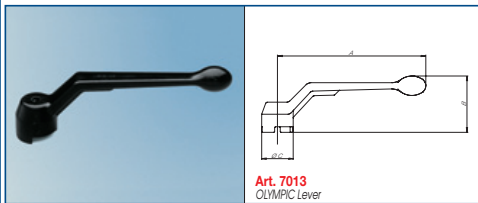

OLYMPIC	DN20-25	DN32-40	DN50	DN65-100			
Amm	160	195	235				
Bmm	61	67	72				
ØCmm	34	44	50				
				TOTAL 2 1/2"-3"			

TRIFLUX	1/2"	3/4"-1"	1 1/4"-1 1/2"	2"			
Amm	130	160	195	235			
Bmm	51	56	63	69			
ØCmm	30	34	44	49			

SPARE PARTS

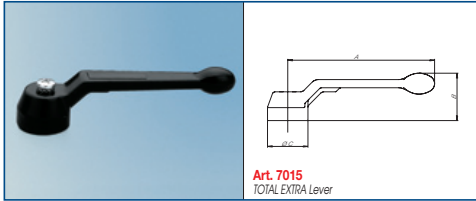

Art. 7015
TOTAL EXTRA Lever

TOTAL EXTRA	1/2"-1"								
Amm	120								
Bmm	39								
ØCmm	33								

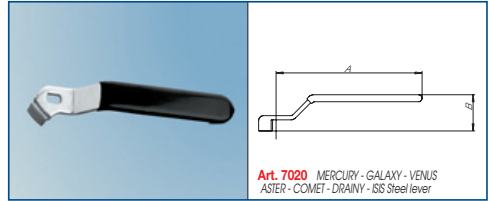

Art. 7020 MERCURY - GALAXY - VENUS
ASTER - COMET - DRAIN - ISIS Steel lever

MERCURY	1/4"-1/2"	3/4"-1"	1 1/4"-1 1/2"	2"	2 1/2"-4"				
GALAXY	*	3/4"-1"	1 1/4"-1 1/2"	2"	2 1/2"-4"				
VENUS	1/4"-1/2"	3/4"-1"	1 1/4"-1 1/2"	2"	2 1/2"-4"				
ASTER	*	3/4"-1"	1 1/4"-1 1/2"	2"	2 1/2"-4"				
COMET	1/4"-1/2"	3/4"-1"	1 1/4"-1 1/2"	2"	2 1/2"-4"				
DRAIN	*	3/4"-1"							
ISIS	1/4"-1/2"	3/4"-1"	1 1/4"-1 1/2"	2"					
Amm	*	105	130	165	250				
Bmm	1/4"-1/2"	27	32	38	40				

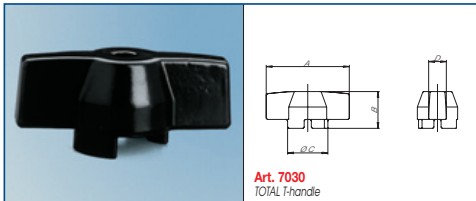

Art. 7030
TOTAL T-handle

TOTAL	1/8"-1/4"	3/8"-1/2"	3/4"-1"						
Amm	45	55	70						
Bmm	22	27	31						
ØCmm	25	30	34						
Dmm	12	13	15						

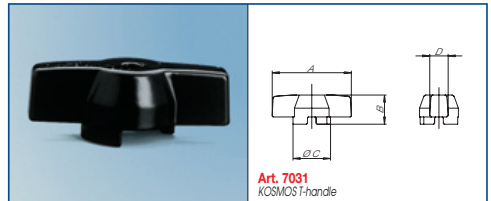

Art. 7031
KOSMOS T-handle

KOSMOS	1/8"-1/4"	3/8"	1/2"-3/4"	1"					
Amm	TOTAL 1/8"-1/4"	TOTAL 1/8"-1/4"	TOTAL 3/8"-1/2"	TOTAL 3/4"-1"					
Bmm									
ØCmm									
Dmm									

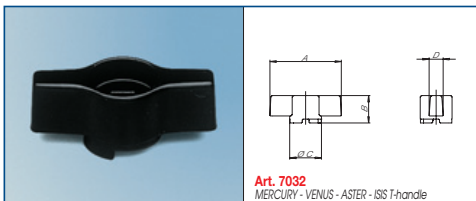

Art. 7032
MERCURY - VENUS - ASTER - ISIS T-handle

MERCURY	1/4"-1/2"	3/4"-1"							
VENUS	1/4"-1/2"	3/4"-1"							
ASTER	1/4"-1/2"	3/4"-1"							
ISIS	1/4"-1/2"	3/4"-1"							
Amm	47	56							
Bmm	16	20							
ØCmm	22	25							
Dmm	11	12							

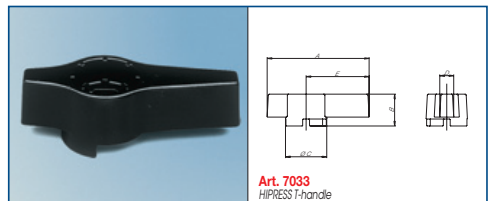

Art. 7033
HIPRESS T-handle

HIPRESS	3/8"-1/2"	3/4"-1"							
Amm	73	110							
Bmm	28	34							
ØCmm	36	44							
Dmm	10	15							
Emm	43	68							

SPARE PARTS

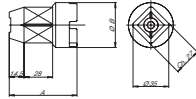

Art. 7052
Underground adaptor TOTAL

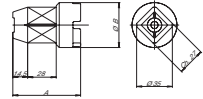

Art. 7053 Underground adaptor
MERCURY - GALAXY - VENUS

TOTAL	3/8"-1/2"	3/4"-1"	1 1/4"-1 1/2"	2"	2 1/2"-3"		
Amm	59	62	66	68	93		
Bmm	29	34	43	48	65		

MERCURY	1/4"-3/8"-1/2"	3/4"-1"	1 1/4"-1 1/2"	2"	2 1/2"-3"-4"		
GALAXY	1/4"-3/8"-1/2"	3/4"-1"	1 1/4"-1 1/2"	2"	2 1/2"-3"-4"		
VENUS	1/4"-3/8"-1/2"	3/4"-1"	1 1/4"-1 1/2"	2"	2 1/2"-3"-4"		
Amm	56	56	61	59	62		
ØBmm	23	26	33	38	48		

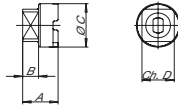

Art. 7055 Square Cup
MERCURY - VENUS - COMET

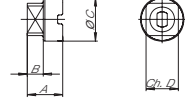

Art. 7056 Sealing Cap MERCURY
VENUS - COMET (without drilling)

MERCURY	1/4"-1/2"	3/4"-1"	1 1/4"-1 1/2"	2"	2 1/2"-4"		
VENUS	1/4"-1/2"	3/4"-1"	1 1/4"-1 1/2"	2"	2 1/2"-4"		
COMET	3/8"-1/2"	3/4"-1"	1 1/4"-1 1/2"	2"	2 1/2"-4"		
Amm	15	20	26	30	40		
Bmm	7	9	12	14	19		
ØCmm	22	25	32	37	48		
chDmm	17	19	24	30	36		

MERCURY	1/4"-1/2"	3/4"-1"	1 1/4"-1 1/2"	2"	2 1/2"-4"		
VENUS	1/4"-1/2"	3/4"-1"	1 1/4"-1 1/2"	2"	2 1/2"-4"		
COMET	3/8"-1/2"	3/4"-1"	1 1/4"-1 1/2"	2"	2 1/2"-4"		
Amm	15	20	26	30	40		
Bmm	7	9	12	14	19		
ØCmm	22	25	32	37	48		
chDmm	17	19	24	30	36		

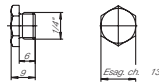

Art. 7060
Plug for DRAIN

Dimensions remain unchanged for all sizes

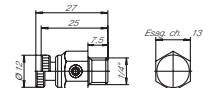

Art. 7065
Drain cock for DRAIN

Dimensions remain unchanged for all sizes



Art. 7069G402
Drain cock T-handle



Art. 7069G402
Rotating drain cock

SPARE PARTS

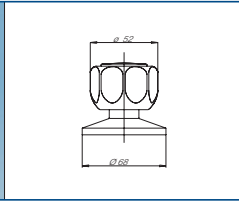

Art. 7100
INCAS K Knob/rosette (operation kit)

Dimensions remain unchanged for all sizes

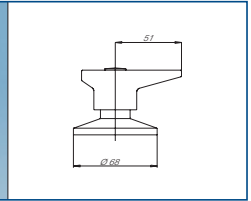

Art. 7105
INCAS K Lever/rosette (operation kit)

Dimensions remain unchanged for all sizes

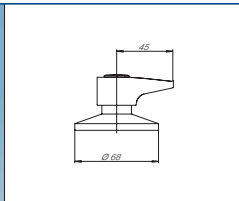

Art. 7125
INCAS M Lever/rosette (operation kit)

Dimensions remain unchanged for all sizes

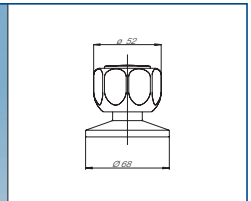

Art. 7130
INCAS EXTRA Knob/rosette (operation kit)

Dimensions remain unchanged for all sizes

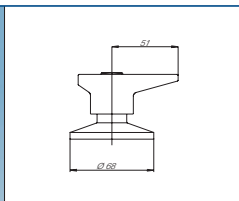

Art. 7135
INCAS EXTRA Lever/rosette (operation kit)

Dimensions remain unchanged for all sizes

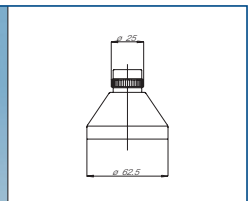

Art. 7140
INCAS K - INCAS M - INCAS EXTRA Cap/bell (operation kit)

Dimensions remain unchanged for all sizes



Art. 7150
Extension set for knob/lever INCAS K - INCAS M

Dimensions remain unchanged for all sizes



Art. 7170
Extension set for INCAS EXTRA Knob and lever

Dimensions remain unchanged for all sizes

SPARE PARTS FOR BUTTERFLY VALVES

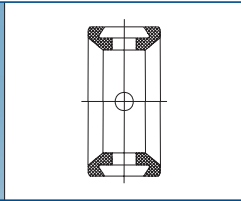
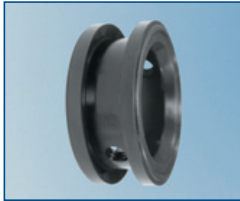

Art. K550E
SEAT EPDM

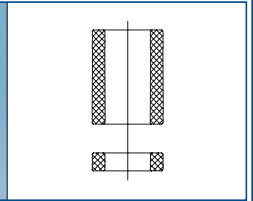

Art. K550E
UPPER SEAL EPDM

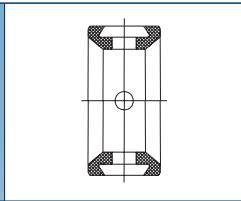
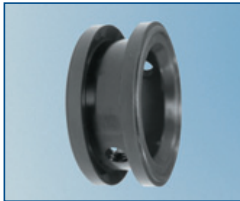

Art. K550N
SEAT NBR

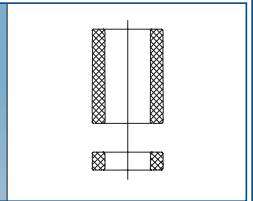

Art. K550N
UPPER SEAL NBR

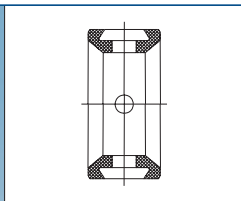

Art. K550V
SEAT VITON

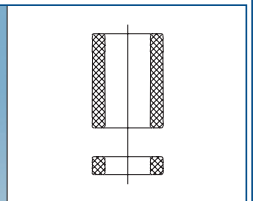

Art. K550V
UPPER SEAL VITON

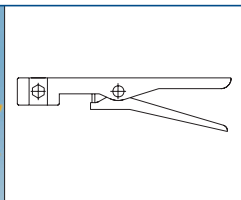

Art. LVA1
Hand lever

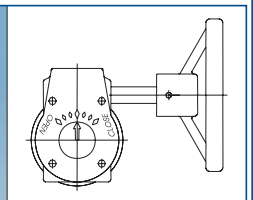

Art. RDA1
Reduction gear

*
available also for gas with yellow handwheel

VALVES ACCESSORIES

VALVES-ACTUATORS CONNECTING KIT

Connecting kit actuator-valve, series SUN WP, MOON, SELENE, TITAN-ARGOS, GEMINI

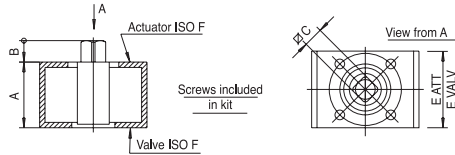
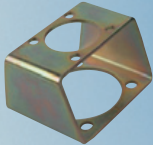

KIT CODE	SERIES	E AT.	E VA.	A	B	∠C	Square red. stand.	ISO F valve	ISO F actuator	KIT CODE	SERIES	E AT.	E VA.	A	B	∠C	Square red. stand.	ISO F valve	ISO F actuator
K1GA0003	SUN WP	34	34	40	11	11	-	F03	F03	K1GA0014	SELENE	120	120	80	26	27	-	F12	F12
K1GA0204	SUN WP	34	34	40	11	11	11-14	F03	F03	K1GA0114	SELENE	200	200	100	46	46	-	F12	F16
K1GA0105	SUN WP	34	34	40	11	11	-	F03	F03	K1GA0015	SELENE	140	140	80	36	36	-	F12	F14
K1GA0205	SUN WP	34	34	40	11	11	11-14	F03	F03	K1GA0115	SELENE	200	200	100	46	46	-	F12	F16
K1GA0206	SUN WP	34	34	40	15	14	-	F03	F03	K1GA0002	TITAN-ARG.	34	34	40	11	11	-	F03	F03
K1GA0306	SUN WP	46	34	40	15	14	-	F03	F05	K1GA0102	TITAN-ARG.	46	34	40	11	11	11-14	F03	F05
K1GA0207	SUN WP	46	40	50	15	14	-	F04	F05	K1GA0304	TITAN-ARG.	34	34	40	15	14	-	F03	F03
K1GA0307	SUN WP	46	40	50	15	14	14-17	F04	F05	K1GA0404	TITAN-ARG.	46	34	40	15	14	14-17	F03	F05
K1GA0208	SUN WP	46	40	50	16	17	-	F04	F05	K1GA0305	TITAN-ARG.	34	34	40	15	14	-	F03	F03
K1GA0009	SUN WP	46	46	50	16	17	-	F05	F05	K1GA0405	TITAN-ARG.	46	34	40	15	14	14-17	F03	F05
K1GA0109	SUN WP	65	46	50	16	17	17-22	F05	F07	K1GA0406	TITAN-ARG.	46	40	50	15	14	-	F04	F05
K1GA0004	MOON	34	34	40	11	11	-	F03	F03	K1GA0506	TITAN-ARG.	46	40	50	15	14	14-17	F04	F05
K1GA0104	MOON	34	34	40	11	11	11-14	F03	F03	K1GA0407	TITAN-ARG.	46	40	50	15	14	-	F04	F05
K1GA0005	MOON	46	34	40	11	11	11-14	F03	F03	K1GA0507	TITAN-ARG.	46	40	50	15	14	14-17	F04	F05
K1GA0006	MOON	46	40	50	15	14	-	F04	F03	K1GA0308	TITAN-ARG.	46	46	50	16	17	-	F05	F05
K1GA0106	MOON	46	40	50	15	14	14-17	F04	F05	K1GA0408	TITAN-ARG.	65	46	50	16	17	17-22	F05	F07
K1GA0007	MOON	46	40	50	15	14	-	F04	F05	K1GB0002	GEMINI	46	40	50	11	11	-	F04	F03
K1GA0107	MOON	46	40	50	15	14	14-17	F04	F05	K1GB0102	GEMINI	46	40	50	11	11	11-14	F04	F03
K1GA0008	MOON	46	46	50	16	17	-	F05	F05	K1GB0104	GEMINI	46	40	50	11	11	11-14	F04	F05
K1GA0108	MOON	65	46	50	16	17	-	F05	F07	K1GB0005	GEMINI	46	46	50	11	14	-	F05	F05
K1GA0010	MOON	70	70	60	16	17	-	F07	F07	K1GB0105	GEMINI	46	46	50	11	14	-	F05	F05
K1GA0110	MOON	70	70	60	16	17	17-22	F07	F07	K1GB0106	GEMINI	46	46	50	11	14	14-17	F05	F05
K1GA0011	MOON	70	70	60	21.5	22	-	F07	F07	K1GB0007	GEMINI	46	46	50	11	17	-	F05	F05
K1GA0111	MOON	90	90	60	21.5	22	22-27	F07	F10	K1GB0107	GEMINI	46	46	50	11	17	-	F05	F05
K1GA0012	MOON	120	120	80	21.5	22	-	F10	F10	K1GB0008	GEMINI	70	70	60	11	17	-	F07	F07
K1GA0112	MOON	120	120	80	21.5	22	22-27	F10	F10	K1GB0108	GEMINI	70	70	60	11	17	17/22	F07	F07
K1GA0013	SELENE	120	120	80	26	27	-	F10	F10	K1GB0009	GEMINI	70	70	60	11	17	-	F07	F07
K1GA0113	SELENE	140	140	80	26	27	27-36	F10	F14	K1GB0109	GEMINI	70	70	60	11	17	17/22	F07	F07

Connecting kit actuator-valve, series TOTAL (TRIFLUX, DELTA, OLYMPIC), OLYMPIC HIPRESS

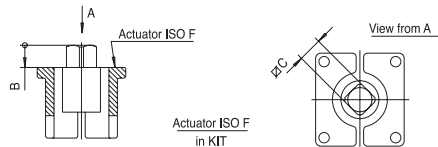

KIT CODE	SERIES	B	∠C	Square red. stand.	ISO F actuator	KIT CODE	SERIES	B	∠C	Square red. stand.	ISO F actuator
KABBO003	TOTAL	11	11	-	F03	KABBO009	TOTAL	16	17	17-22	F07
KABBO103	TOTAL	15	14	-	F05	KABBO109	TOTAL	16	17	17-22	F07
KABBO005	TOTAL	11	11	-	F03	KABBO010	TOTAL	16	17	-	F07
KABBO105	TOTAL	15	14	-	F05	KABBO110	TOTAL	16	17	17-22	F07
KABBO006	TOTAL	15	14	-	F05	KABBO011	TOTAL	21.5	22	-	F07
KABBO106	TOTAL	16	17	-	F05	KABBO012	OLYMPIC	21.5	22	22-27	F10
KABBO007	TOTAL	15	14	-	F05	K1BA0003	HIPRESS	11	11	-	F03
KABBO107	TOTAL	15	14	14-17	F05	K1BA0103	HIPRESS	15	14	-	F05
KABBO008	TOTAL	15	14	-	F05	K1BA0005	HIPRESS	15	14	-	F05
KABBO108	TOTAL	15	14	14-17	F05	K1BA0105	HIPRESS	16	17	-	F05

ATTENTION: IN MOST CASES THE VALVE FOR ACTUATOR DIFFERS FROM THE MANUAL ONE

ACTUATOR ACCESORIES

SOLENOID VALVES - LIMIT SWITCHES

5/2 and 3/2 way NAMUR monostable solenoid valve multifunctional



Valve with air spring
Emergency screw
Reduced outside dimensions
Airflow 750 l/min for standard version
IP65 to DIN 40050
Body in anodised aluminium
Inside parts in polycarbonate and brass
Seals in NBR
Working pressure from 2 to 10 bar
Working temperature from -10°C to +70°C
Voltage: DC: 12V, 24V; AC: 24V, 48V, 110V, 230V
On request: explosion-proof coil EExm II T4-T5
Intrinsic safety coil EExia IIC T6

Art. EVNM

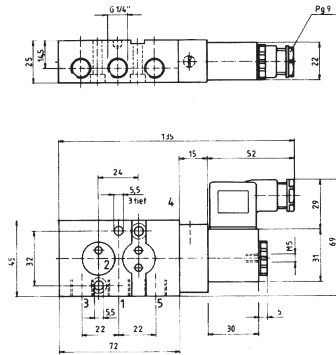

5/2 way NAMUR bistable solenoid valve



Emergency screw
Reduced outside dimensions
Airflow 750 l/min for standard version
IP65 to DIN 40050
Body in anodised aluminium
Inside parts in polycarbonate and brass
Seals in NBR
Working pressure from 2 to 10 bar
Working temperature from -10°C to +70°C
Voltage: DC: 12V, 24V; AC: 24V, 48V, 110V, 230V
On request: explosion-proof coil EExm II T4-T5
Intrinsic safety coil EExia IIC T6

Art. EVNB

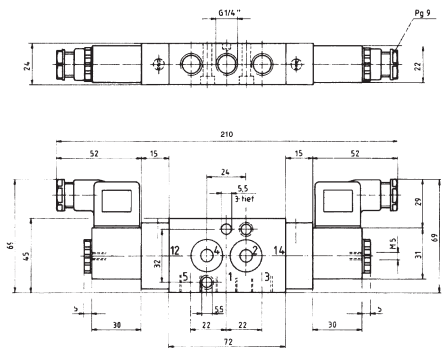

Solenoid valve NAMUR with combined 5/2- and 3/2-ways function + explosionproof coil EEx m II T4-T5



Manual override as standard
Air entry G 1/4"
Dimension 5 mm
Air pressure 2 - 10 bar
Temperature -10°C a +70°C
Enclosure IP65 / DIN 40050
Voltage: DC=12V,24V AC=24V,48V,110V,220V
Power consumption 3W 3W 5VA 5VA 5VA 5VA
Air flow 750 l/min
Serial number stamped
Easy change over from 5/2- to 3/2-ways operation
by innovative soaling-plato to be turned around
Single stable or dual stable version
Reduced external dimension

Art. EVEM

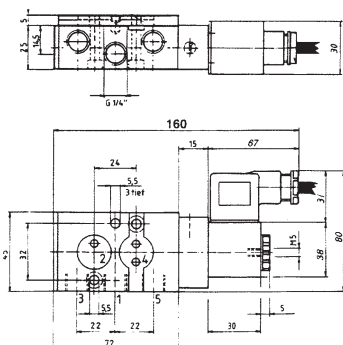

Solenoid valve NAMUR with combined 5/2- and 3/2-ways function + explosionproof coil EEx m II T4-T5



Manual override as standard
Air entry G 1/4"
Dimension 5 mm
Air pressure 2 - 10 bar
Temperature -10°C a +70°C
Enclosure IP65 / DIN 40050
Voltage: DC=12V,24V AC=24V,48V,110V,220V
Power consumption 3W 3W 5VA 5VA 5VA 5VA
Air flow 750 l/min
Serial number stamped
Easy change over from 5/2- to 3/2-ways operation
by innovative soaling-plato to be turned around
Single stable or dual stable version
Reduced external dimension

Art. EVEB

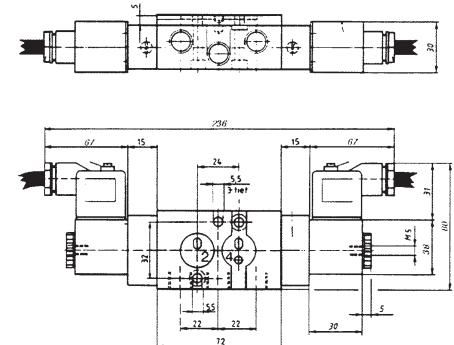

ACTUATOR ACCESSORIES

MICROSWITCHES BOX

Box in aluminium with mechanical microswitches, with 3D



IP66

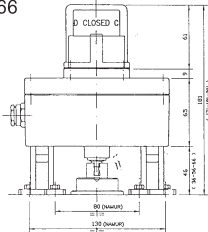

Art. GZ01BA01

Box: IP66, GD AISI12 - DIN232 ASTM SC114A
Shaft in stainless steel AISI 303,
screws in SS AISI 304
Cams in plastic material
Cable clamping in nickel-plated brass PG11
3D position indicator in plastic material
Interchangeable protected microswitches in polyamide

Seals in nitrile rubber BUNA N.
Adjustable bracket 80/130mm in width
Microswitches: Crouzet IP66 250V AC-10(2) A.
Working temperature from -20°C to +80°C
Stock temperature from -30°C to +80°C

Box in Polycarbonate with mechanical microswitches, with 3D



IP65

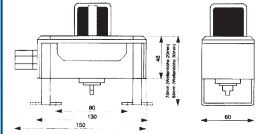

Art. GZ01BCH2

Box: IP65, DIN 40050, Polycarbonate
Shaft in stainless steel AISI 303,
screws in SS AISI 304
Cams in Polyamide
Black cable clamping PG 13.5
Mounting bracket in AISI 304
3D position indicator in plastic material

Seals in EPDM, NBR
Maximum overall dimensions: 180x119x60mm
Adjustable bracket 80/130mm in width
Microswitches: Crouzet IP65 250V AC-10(2) A.
Working temperature from -20°C to +80°C

Box in Polycarbonate with mechanical microswitches



IP65

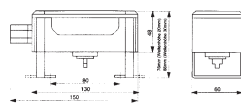

Art. GZ01BCA2

Box: IP65, DIN 40050, Polycarbonate
Shaft in Polyamide, screws in SS AISI 304
Cams in Polyamide
Black cable clamping PG 13.5
Mounting bracket in AISI 304
Seals in EPDM, NBR

Maximum overall dimensions: 180x88x60mm
Adjustable bracket 80/130mm in width
Microswitches: Crouzet IP65 250V AC-10(2) AC
10(2) A - "V4" Din 41635 B
Working temperature from -20°C to +80°C

Box in Polycarbonate with proximity switches, with 3D



IP67

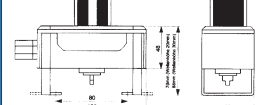

Art. GZ01ABH2

Box: IP65, DIN 40050, Polycarbonate
Shaft in AISI 303, screws in AISI 304
Cams in Polyamide
Mounting bracket in AISI 304
3D position indicator in plastic material, yellow LED

Seals in EPDM, NBR
Maximum overall dimensions: 180x119x60mm
Adjustable bracket 80/130mm in width
Microswitches: P-F-IP67 Type NB B2 - V3 - E2,
0-30 V CC 0-100 mA 1000 H2; min. current 15 mA
Working temperature from -20°C to +80°C

Box in aluminium with explosion-proof microswitches EExd, with 3D



ATEX: 94/9/CE

IP66

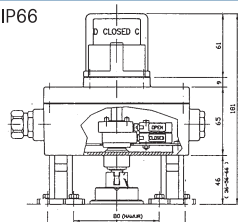

Art. GZ01CA04

Box: IP66, GD AISI12 - DIN232 ASTM SC114A
Shaft AISI 303, screw AISI 304
Cams in plastic material
2 fittings with Ø1/2" nickel plated brass plug
3D position indicator in plastic material
Microswitches: explosion-proof in polyamide
+4 cables 2m, sect. 0,75 sq. mm

Seals in nitrile rubber BUNA N.
Adjustable bracket in height and width
Microswitches: Crouzet type 83 139.1 EEX DILC TE
250V AC-6 (11) A - EN 50014+50018
Working temperature from -20°C to +80°C
Stock temperature from -30°C to +80°C

Box in aluminium with intrinsic safety proximity switches EExia, with 3D



IP65

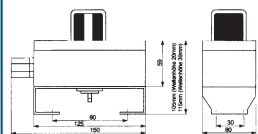

Art. GZ01DB01

Box: IP65, DIN 40050, Aluminium
Shaft in AISI 303, screws in AISI 304
Cams in Polyamide, seals in EPDM, NBR
Black cable clamping PG 13.5
Mounting bracket in AISI 304
3D position indicator in plastic material

Maximum overall dimensions: 180x151x60mm
Standard version bracket: 80mm axle base
Microswitches: P-F-IP67 Type NB
8V CC 1 mA in on - 3 mA in off, 1000 H2
EMC EN 60947-5-2, min current 15 mA
Working temperature from -20°C to +100°C

DIAGRAMS

Pressure/temperature diagram

The pressure curves have been drawn on the basis of laboratory tests by using predetermined temperature values. Since the curves are a mediation of said values, these are only indicative of the potential real performance of ball valves.

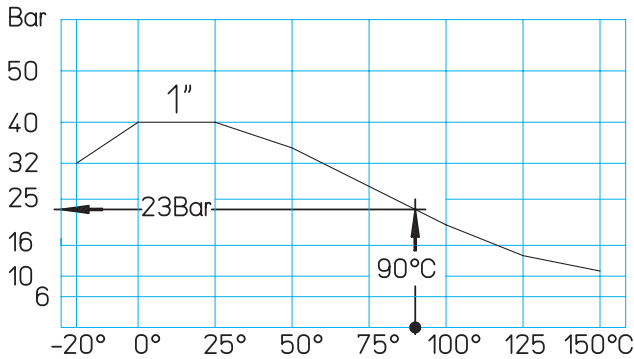

EXAMPLE: To determine at which maximum pressure a ball valve of 1" can resist at 90°C, one has to act in this way: raise from the temperature line the X-axis till it meets the oblique line. Pull from that point a horizontal line till it meets the ordinate. The value obtained will be 23 bar.

Loss of head/flow rate diagram

The curves of flow rate diagram have been drawn on the basis of laboratory tests. The Kv value indicates a volumetric normalised flow rate of a ball valve completely open, at a temperature of 5°/40°C causing a loss of head of 1 bar (10⁵ Pa)

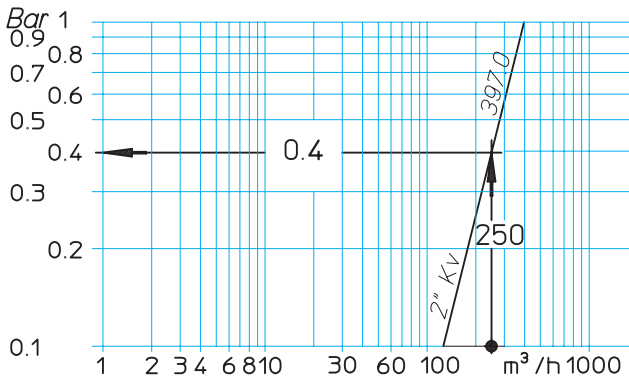

1 = EXCELLENT • 2 = GOOD 3 = NOT TOO GOOD • 4 = RISKY -- = NO INFORMATION AVAILABLE		CONCENTRATION	TEMPERATURE °C	ASI 304 18/8/2		ASI 316 18/8/2		CARBON STEEL A 105/A2 (AWCB)	CAST IRON	BRASS
B = BOILING • C = HOT Ta = ROOM TEMPERATURE				CF8M 1.4401 -1.4408	CF8M 1.4401 -1.4408					
COMPOUND										
A										
Acetaldehyde		Ta	1	1	3	3	1			
Acetilene		+20	1	1	1	1	4			
Acetic Acid	10%	+20	1	1	4	4	2			
Acetic Acid	10%	B	2	4	4	4	4			
Acetic Acid	20-80%	+20	1	2	4	4	4			
Acetic Acid	80%	B	2	2	4	4	4			
Acetic Acid (vapours)	30%	C	3	3	4	4	4			
Acetic Anhydride		B	2	2	3	3	3			
Acetic Ester	Concentrated	+20	1	1	2	2	--			
Acetic Solvents		Ta	1	1	1	2	--			
Acetone		B	1	1	2	2	1			
Acido Cressilico		+20	1	1	2	2	2			
Acido Idrofluorosilicico		Ta	3	3	4	4	2			
Acrylonitrile		Ta	1	1	1	1	--			
Alcool Diacetone		Ta	1	1	1	1	--			
Alum	10%	B	2	2	4	4	2			
Alum	saturated	B	3	2	4	4	--			
Aluminium Chloride	25%	+20	4	3	4	4	4			
Aluminium (Chloride)	25%	+20	4	3	4	4	--			
Aluminium (Fluoride)	5%	+20	4	3	4	4	--			
Aluminium Sulfate		+20	2	2	4	4	--			
Aluminium Sulfate		B	3	2	4	4	--			
Aluminium Sulphate		Ta	2	1	3	3	3			
Ammines		+20	1	1	1	1	--			
Ammonia	concentrated	+20	1	1	2	2	1			
Ammonia	acquarosa	Ta	1	1	1	1	4			
Ammonia	gaseous	C	4	4	3	3	--			
Ammonium Bicarbonate		Ta	2	2	3	3	--			
Ammonium Carbonate		+20	2	2	2	2	--			
Ammonium Carbonate		Ta	2	2	2	2	--			
Ammonium Chloride	10%	+20	2	2	3	3	4			
Ammonium Chloride	10%	+20	2	2	3	3	--			
Ammonium Chloride	10%	B	3	2	4	4	--			
Ammonium Disulphate		+20	1	1	3	3	--			
Ammonium Hydroxide	Concentrated	C	1	1	2	2	--			
Ammonium Hydroxide		Ta	1	1	2	2	--			
Ammonium Hydroxide		C	1	1	2	2	4			
Ammonium Monophosphate		+20	1	1	4	4	--			
Ammonium Monophosphate		+20	1	1	4	4	--			
Ammonium Nitrate		+20	2	2	2	2	--			
Ammonium Nitrate	Saturated	B	2	2	3	3	--			
Ammonium Nitrate		+20	2	2	2	2	4			
Ammonium Persulphate	5%	+20	2	2	4	4	--			
Ammonium Phosphate		Ta	2	2	4	4	--			
Ammonium Sulphate	5%	+20	3	2	3	3	--			
Ammonium Sulphate	10%	B	4	3	4	4	--			
Ammonium Sulphate	Saturated	B	4	3	4	4	--			
Ammonium Sulphate		+20	3	2	3	3	4			
Ammonium Trisulphate		+20	2	1	2	2	--			
Amyl Acetate	concentrated	+20	2	2	2	2	--			
Amyl Acetate		Ta	2	2	3	3	2			
Amyl Alcohol	concentrated	+20	1	1	4	4	1			
Aniline	3%	+20	1	1	2	2	3			
Aniline	Concentrated	+20	2	2	2	2	3			
Aniline (dyes)		Ta	1	1	3	3	3			
Animal Oil		Ta	1	1	1	1	--			
Antimony Trichloride		+20	4	4	4	4	--			
Antimony Trichloride		Ta	4	4	4	4	--			
Apple Juice		Ta	2	2	4	4	4			
Asphalt		Ta	1	1	2	2	1			
B										
Barium Chloride	Saturated	+20	3	2	3	3	3			
Barium Chloride	Water sol.	C	4	3	4	4	3			
Barium Carbonate		Ta	2	2	2	2	1			
Barium Chloride	5%	+20	2	2	3	3	4			
Barium Hydroxide		Ta	2	2	3	3	2			
Barium Sulphate	Saturated	+20	3	2	2	2	1			

1 = EXCELLENT • 2 = GOOD 3 = NOT TOO GOOD • 4 = RISKY -- = NO INFORMATION AVAILABLE		CONCENTRATION	TEMPERATURE °C	ASI 304 18/8/2		ASI 316 18/8/2		CARBON STEEL A 105/A2 (AWCB)	CAST IRON	BRASS
B = BOILING • C = HOT Ta = ROOM TEMPERATURE				CF8M 1.4401 -1.4408	CF8M 1.4401 -1.4408					
COMPOUND										
Barium Sulphate		+20	2	2	2	2	2	2		
Barium Sulphite		Ta	2	2	3	3	1			
Benzaldehyde		Ta	1	1	1	1	--			
Benzoic Acid		+20	2	2	2	2	2			
Benzol		C	2	2	2	2	1			
Borax		+20	1	1	2	2	1			
Boric Acid	5%	C	2	2	4	4	2			
Brine		Ta	2	2	3	3	2			
Bromine		+20	4	4	4	4	4			
Butadiene		Ta	1	1	1	1	1			
Butane		Ta	1	1	1	1	1			
Butyric Acid	5%	+70	2	2	3	3	4			
Butyl Alcohol		Ta	1	1	2	2	1			
Butylene		Ta	1	1	1	1	--			
Butyl Acetate		+20	2	2	1	1	--			
C										
Calcium Bisulphite		+20	3	2	4	4	2			
Calcium Bisulphite		+20	3	2	4	4	2			
Calcium Carbonate		+20	2	2	2	2	1			
Calcium Carbonate		+20	2	2	2	2	1			
Calcium Chloride		+20	3	2	3	3	4			
Calcium Chloride	Diluted	+20	3	2	3	3	4			
Calcium Chloride	Concentrated	+20	4	3	3	3	4			
Calcium Chloride	Concentrated	B	4	4	4	4	4			
Calcium Chloride	5%	+20	2	2	2	2	2			
Calcium Hydroxide	10%	B	2	2	4	4	2			
Calcium Hydroxide	50%	B	4	2	4	4	2			
Calcium Hypochlorite	2%	+20	3	3	4	4	4			
Calcium Hydroxide		Ta	1	1	1	1	--			
Calcium Hydroxide		+20	2	2	2	2	2			
Calcium Hypochlorite		+20	3	3	4	4	4			
Calcium Sulphate		Ta	2	2	3	3	1			
Calcium Sulphate	Saturated	+20	2	2	2	2	--			
Carbolic Acid		B	2	2	3	3	--			
Carbonic Acid	saturated	+20	2	2	4	4	--			
Carbon Dioxide		Ta	1	1	1	1	1			
Carbon Disulphide		+20	2	2	2	2	2			
Carbon Sulphite		Ta	2	2	2	2	4			
Carbon Monoxide		B	1	1	1	1	--			
Carbon Tetrachloride		+20	2	2	2	2	3			
Carbon Tetrachloride		B	3	3	4	4	3			
Carbon Tetrachloride	Dry	Ta	1	1	2	2	3			
Carbon Tetrachloride	Wet	Ta	2	2	4	4	4			
Caustic Soda	5%	+20	2	2	2	2	--			
Caustic Soda	20%	B	1	1	2	2	--			
Caustic Soda	50%	B	2	2	3	3	--			
Caustic Soda	75%	B	3	3	4	4	--			
Chlorinated Solvents	Dry	Ta	2	2	3	3	--			
Chloroacetic Acid		+20	4	4	4	4	4			
Chlorobenzene	Concentrated	+20	1	1	1	1	--			
Chloroform		+20	1	1	1	1	1			
Chlorous Acid		+20	4	4	4	4	4			
Chlorosulfonic Acid	10%	+20	3	2	4	4	3			
Chlorosulfonic Acid	concentrated	+20	2	2	4	4	3			
Chromic Acid	5%	+20	2	2	2	2	4			
Chromic Acid	50% com.	B	4	4	4	4	4			
Citric Acid	5%	+20	1	1	4	4	3			
Citric Acid	15%	B	2	2	4	4	3			
Citric Acid	concentrated	B	4	2	4	4	3			
Colophony		Ta	1	1	4	4	--			
Coke-oven Gas		Ta	1	1	2	2	--			
Copper Acetate		Ta	1	1	4	4	--			
Copper Acetate	Saturated	+20	2	2	4	4	--			
Copper Chloride	19%	+20	3	2	3	2	4			
Copper Chloride	1%	+20	3	2	4	4	--			
Copper Chloride	5%	B	4	4	4	4	--			
Copper Nitrate	5%	+20	1	1	4	4	3			
Copper Nitrate	5%	220	1	1	4	4	--			
Copper Nitrate	50%	C	2	2	4	4	--			

COMPOUND	CONCENTRATION	TEMPERATURE °C	1 = EXCELLENT • 2 = GOOD 3 = NOT TOO GOOD • 4 = RISKY -- = NO INFORMATION AVAILABLE			
			ASI 304/18/8/2 CF8M 1.4401 -1.4408	ASI 316/18/8/2 CF8M 1.4401 -1.4408	CARBON STEEL A105/A21/WCB	CAST IRON BRASS
B = BOILING • C = HOT Ta = ROOM TEMPERATURE						
Copper Sulphate	Saturated	+20	2	2	4	4
Copper Sulphate		B	2	2	4	4
Copper Sulphate		+20	2	2	4	4
Creosote		C	2	2	2	2
Creosote Oil		Ta	2	2	2	2
Cyclohexane	Ta	1	1	1	1	
D						
Dichloroethane		B	2	2	4	4
Diethylamine		Ta	1	1	1	1
Diethyl Ether		+20	1	1	1	2
Distilled water		Ta	1	1	3	3
E						
Epsom Salt		Ta	2	2	3	3
Ethane		Ta	2	2	2	2
Ethyl Acrylate		Ta	1	1	3	3
Ethyl Alcohol		B	2	2	2	2
Ethyl Acetate		Ta	2	2	2	2
Ethyl Chloride	Dry	+20	1	1	1	1
Ethyl Chloride		+20	1	1	1	1
Ethylene Glycol		+20	1	1	1	1
Ethylene Oxide		Ta	2	2	2	2
F						
Fatty Acids		B	2	2	3	3
Ferric Chloride	1%	+20	4	3	4	4
Ferric Chloride	5%	+20	4	4	4	4
Ferric Nitrate		Ta	3	3	4	4
Ferric Nitrate	5%	+20	2	2	4	4
Ferric Sulphate		+20	2	1	4	4
Ferric Sulphate	5%	B	2	2	4	4
Ferrous Chloride		Ta	4	4	4	4
Ferrous Sulphate	Saturated	+20	2	2	4	4
Ferrous Sulphate		10%	+20	2	2	4
Fertilizers		Ta	2	2	2	2
Fish Oil		Ta	1	1	2	2
Fluorine	Dry	+20	2	2	4	4
Formaldehyde		Cold	1	1	1	2
Formaldehyde		Hot	3	3	4	3
Formic Acid	5-50%	+20	2	2	4	4
Formic Acid	10-50%	B	4	4	4	4
Formic Acid	100%	+20	3	3	4	4
Formic Acid	100%	B	4	4	4	4
Freon	Dry	Ta	1	1	1	1
Freon		Wet	Ta	3	3	3
Fuel Oil		Ta	1	1	2	2
Furfuraldehyde		+20	2	2	2	2
G						
Gallic Acid	5%	+70	2	2	4	4
Gas Chlorate	Dry	+20	4	3	2	2
Gas Chlorate		Wet	+100	4	4	4
Gaseous Methyl Chloride		+20	2	2	4	4
Gelatine		Ta	1	1	4	4
Glue		Ta	2	2	1	1
Glucose		Ta	2	2	2	2
Glycerol		+20	1	1	1	1
Glycols		Ta	2	2	2	2
H						
Heptane		Ta	1	1	2	2
Hexane		Ta	2	2	2	2
Hexanol		Ta	1	1	1	1
Hydraulic Oil		Ta	1	1	1	1
Hydroic Acid (iodidrico)	diluted	+20	4	4	4	4
Hydrocarbons		+20	1	1	1	1
Hydrobromic Acid		+20	4	4	4	4
Hydrocyanic Acid		+20	2	2	3	3
Hydrochloric Acid	1%	+20	4	3	4	4

COMPOUND	CONCENTRATION	TEMPERATURE °C	1 = EXCELLENT • 2 = GOOD 3 = NOT TOO GOOD • 4 = RISKY -- = NO INFORMATION AVAILABLE			
			ASI 304/18/8/2 CF8M 1.4401 -1.4408	ASI 316/18/8/2 CF8M 1.4401 -1.4408	CARBON STEEL A105/A21/WCB	CAST IRON BRASS
B = BOILING • C = HOT Ta = ROOM TEMPERATURE						
Hydrochloric Acid	1%	B	4	4	4	4
Hydrochloric Acid	5%	+20	4	4	4	4
Hydrochloric Acid		+20	4	4	4	4
Hydrofluoric Acid	concentrated	+20	4	4	4	4
Hydrofluoric Acid		dry	+20	3	3	3
Hydrofluoric Acid		+20	4	4	4	4
Hydrofluoric Acid		+20	4	4	4	4
Hydrogen Gas	Cold	Ta	1	1	2	2
Hydrogen dioxide		+20	1	1	4	4
Hydrogen dioxide		B	2	2	4	4
I						
Illuminating Gas		Ta	1	1	1	1
Ink		Ta	1	1	4	4
Iodine	Dry	+20	4	3	4	4
Iodine		Wet	+20	4	4	4
Iodoform		+20	1	1	4	4
Isocotane		Ta	1	1	1	1
Isopropyl Ether		Ta	1	1	1	2
Isopropyl Alcohol		Ta	2	2	2	2
J						
Juices		B	2	1	4	4
K						
Ketone		Ta	1	1	1	1
Kerosene		Ta	1	1	2	2
L						
Lactic Acid	1%	B	2	2	4	4
Lactic Acid	5%	+70	2	2	4	4
Lactic Acid	5%	B	4	2	4	3
Lactic Acid	5-10%	+20	2	1	4	4
Lactic Acid	10%	+70	3	2	4	4
Lactic Acid	10%	B	4	3	4	3
Lactic Acid	concentrated	B	4	4	4	3
Latex		+20	1	1	4	4
Latex Emulsions		Ta	1	1	2	2
Lead Acetate		+20	2	2	4	4
Lead Acetate		Ta	2	2	4	4
Lemon Juice		Ta	2	2	4	4
Linoleic Acid		Ta	1	1	2	2
Linseed Oil		Ta	2	2	1	1
Liquefied Gas (LPG)		Ta	2	2	2	2
Lithium		+150	1	1	2	2
Lubricating Oil		Ta	1	1	1	1
Lye		B	2	2	4	4
Lysol		+20	3	3	4	4
M						
Magnesium Chloride	5%	+20	2	2	4	4
Magnesium Chloride	5%	C	4	4	4	4
Magnesium Chloride	10-30%	+20	3	2	4	4
Magnesium Chloride	Saturated	+20	3	2	4	4
Magnesium Chloride	5%	+20	2	2	4	4
Magnesium Disulphate		Ta	1	1	2	2
Magnesium Hydroxide		C	1	1	2	2
Magnesium Oxide		+20	2	2	2	2
Magnesium Sulphate		+20	2	2	2	3
Magnesium Sulphate		+20	2	2	2	3
Maleic Acid		Ta	2	2	2	2
Malic Acid		C	2	2	4	4
Mercury		+150	3	3	2	2
Mercury		+500	4	4	4	4
Mercury Bichloride	2%	+20	4	4	4	4
Mercury Cyanide		+20	2	2	4	4
Mercury Cyanide		+20	2	2	4	4
Mercuric Chloride		Ta	4	3	4	4
Methane		Ta	2	2	2	1
Methyl Acetate		Ta	1	1	2	2

1 = EXCELLENT • 2 = GOOD
 3 = NOT TOO GOOD • 4 = RISKY
 -- = NO INFORMATION AVAILABLE

B = BOILING • C = HOT
 Ta = ROOM TEMPERATURE

COMPOUND	CONCENTRATION	TEMPERATURE °C	AISI 304/18/10/2 CF8M 1.4401-1.4408		AISI 316/18/10/2 CF8M 1.4401-1.4408		CARBON STEEL A 105/A21/04CB	CAST IRON	BRASS
			1	2	1	2			
Methyl Alcohol		B	3	2	2	2	2	1	
Methylacetone		Ta	1	1	2	2	2	—	
Methylamine		Ta	1	1	2	2	—		
Methyl Chloride		+20	2	2	4	4	2		
Methylene Chloride		Ta	1	1	2	2	2		
Methyl Formate		Ta	2	2	3	3	—		
Milk		+20	1	1	4	4	2		
Mineral Naphtha		+20	2	2	2	2	2		
Mineral Oil		Ta	1	1	2	2	1		
Mineral water		Ta	2	2	3	3	2		
Mixed Acid-turpentine		+20	4	4	4	4	4		
Muriatic Acid		+20	4	3	4	4	4		
N									
Naphthalene		Ta	2	2	1	1	—		
Natural Gas		Ta	1	1	2	2	1		
Neon		+20	2	2	2	2	—		
Nickel Chloride		+20	3	2	4	4	3		
Nickel Chloride		+20	3	2	4	4	3		
Nickel Sulphate		C	3	2	4	4	3		
Nickel Sulphate		C	3	2	4	4	3		
Nickel Nitrate		Ta	2	2	4	4	—		
Nicotinic Acid		Ta	1	1	2	2	—		
Nitric Acid	5-50%	+20	1	1	4	4	4		
Nitric Acid	10-50%	B	2	3	4	4	4		
Nitric Acid	85%	+20	2	2	2	2	4		
Nitric Acid	85%	C	2	3	4	4	4		
Nitric Acid	concentrated	+20	2	2	2	2	2		
Nitric Acid	concentrated anhydrous	B	3	3	4	4	4		
Nitric Acid		Ta	1	1	1	1	4		
Nitrobenzene		Ta	2	2	2	2	—		
Nitrogen		Ta	1	1	1	1	1		
Nitrous Acid	5%	+20	2	2	4	4	—		
Nitrous Gases		Ta	1	1	2	2	—		
Nitrous Oxide		Ta	2	2	2	2	—		
O									
Oil		Ta	1	1	2	2	2		
Oleic Acid	crude	+20	2	2	3	3	—		
Oleum		Ta	2	2	2	2	—		
Olive Oil		Ta	1	1	2	2	3		
Oxalic Acid	5%	C	3	3	4	4	—		
Oxalic Acid	10%	+20	2	2	3	3	—		
Oxalic Acid		B	4	4	4	4	—		
Oxalic Acid	saturated	+20	2	2	3	3	—		
Oxalic Acid	saturated	B	4	4	4	4	—		
Oxygen	Cold		1	1	2	2	1		
Oxygen		+250	2	2	2	2	—		
Ozone	Dry	Ta	1	1	3	3	—		
Ozone	Wet	Ta	1	1	1	1	—		
P									
Paint Varnish		Ta	1	1	3	3	—		
Palm Oil		Ta	2	2	3	3	—		
Palmitic Acid		+20	2	2	3	3	3		
Paraformaldehyde		Ta	2	2	2	2	—		
Paraffin wax		Ta	1	1	1	1	1		
Pentane		Ta	1	1	2	2	—		
Perchloroethylene		Ta	1	1	2	2	3		
Peroxide		Ta	2	2	4	4	4		
Petrol		Ta	1	1	1	1	1		
Petrol (Crude)		+20	1	1	3	3	1		
Phenol		B	2	2	3	3	—		
Phosphoric Acid	C.P1%	+20	2	2	4	4	4		
Phosphoric Acid	5%	+20	2	2	4	4	4		
Phosphoric Acid	10%	+20	3	2	4	4	4		
Phosphoric Acid	20-45%	B	4	3	4	4	4		
Phosphoric Acid	45-85%	+20	4	2	4	4	4		
Phosphoric Acid	85%	B	4	4	4	4	4		
Phthalic Acid		Ta	2	2	3	3	—		

1 = EXCELLENT • 2 = GOOD
 3 = NOT TOO GOOD • 4 = RISKY
 -- = NO INFORMATION AVAILABLE

B = BOILING • C = HOT
 Ta = ROOM TEMPERATURE

COMPOUND	CONCENTRATION	TEMPERATURE °C	AISI 304/18/10/2 CF8M 1.4401-1.4408		AISI 316/18/10/2 CF8M 1.4401-1.4408		CARBON STEEL A 105/A21/04CB	CAST IRON	BRASS
			1	2	1	2			
Phthalic Anhydride			2	2	3	3	—		
Picric Acid	water sol.	+20	2	2	3	3	4		
Potassium Bichromate		+20	2	2	3	3	—		
Potassium Bisulphite		Ta	2	2	4	4	—		
Potassium Bromide		+20	3	2	4	4	—		
Potassium Bromide		+20	3	2	4	4	—		
Potassium Carbonate	1%	+20	2	2	2	2	3		
Potassium Carbonate	1%	+20	2	2	2	2	—		
Potassium Chlorate		+20	2	2	2	2	—		
Potassium Chloride	1-5%	+20	3	2	4	4	3		
Potassium Chlorate		+20	2	2	2	2	4		
Potassium Chloride	1-5%	+20	3	2	4	4	4		
Potassium Chloride	1-5%	B	4	4	4	4	4		
Potassium Cyanide		+20	2	2	2	2	4		
Potassium Cyanide		+20	2	2	2	2	4		
Potassium Dichromate		+20	2	2	3	3	4		
Potassium Diphosphate		Ta	1	1	1	1	—		
Potassium Disulphate	Saturated	+20	2	2	3	3	2		
Potassium Ferricyanide		Ta	2	2	3	3	4		
Potassium Ferricyanide	5%	+20	2	2	3	3	4		
Potassium Hydroxide	5%	+20	2	2	2	2	4		
Potassium Hypochlorite		+20	4	3	4	4	—		
Potassium Iodide	2%	Ta	2	2	3	3	—		
Potassium Nitrate	1-5%	+20	2	2	2	2	2		
Potassium Nitrate	1-5%	C	2	2	2	2	—		
Potassium Permanganate		+20	1	1	1	1	—		
Potassium Permanganate		+20	1	1	1	1	—		
Potassium Sulphate	1-5%	+20	2	2	2	2	2		
Potassium Sulphate	Saturated	+20	2	2	3	3	—		
Potassium Sulphite		+20	2	2	2	2	2		
Potassium Sulphite		Ta	1	1	2	1	2		
Propane		Ta	2	2	2	2	1		
Propanol		Ta	1	1	2	2	—		
Propylene Glycol		Ta	2	2	2	2	—		
Propionic Acid		+20	2	2	4	4	—		
Prussic Acid		+20	2	2	3	3	—		
Pyrogallic Acid		+20	2	2	2	2	—		
Pyroligneous Acid		+20	1	1	4	4	—		
Q									
Quinine Bisulphate	Dry	+20	2	2	4	4	—		
R									
Resins		Ta	1	1	3	3	—		
S									
Sal Ammoniac		+20	2	2	3	3	—		
Salicylic Acid		+20	2	2	4	4	—		
Sea water		+20	2	2	4	4	3		
Shellac		Ta	1	1	1	1	—		
Silver Bromide		+20	3	2	4	4	—		
Silver Chloride		+20	4	4	4	4	—		
Silver Nitrate		+20	2	2	4	4	—		
Silver Nitrate		+20	2	2	4	4	4		
Sludge		Ta	1	1	2	2	—		
Soap		+20	2	2	2	2	2		
Sodium Acetate	Wet	+20	2	2	3	3	—		
Sodium Acetate		Ta	2	2	3	3	—		
Sodium Bicarbonate		+20	2	2	3	3	3		
Sodium Bicarbonate		+20	2	2	3	3	3		
Sodium Bisulphite		Ta	1	1	4	4	2		
Sodium Borate		Ta	2	2	3	3	—		
Sodium Bromide		Ta	2	2	3	4	—		
Sodium Carbonate	5%	+70	2	2	2	2	—		
Sodium Carbonate		+20	2	2	2	2	4		
Sodium Chlorate	10%	+20	2	2	3	3	—		
Sodium Chloride	20%	+20	2	2	3	3	—		
Sodium Chloride	Saturated	B	3	2	4	4	—		
Sodium Chloride		+20	2	2	3	3	4		
Sodium Chloride	5%	+20	2	2	3	3	3		

1 = EXCELLENT • 2 = GOOD 3 = NOT TOO GOOD • 4 = RISKY — = NO INFORMATION AVAILABLE		CONCENTRATION	TEMPERATURE °C	ASIS 304 18/18/2 CF8M 1.4401 - 1.4408		ASIS 316 18/18/2 CF8M 1.4401 - 1.4408		CARBON STEEL A 105/A2 16WCB		CAST IRON	BRASS
B = BOILING • C = HOT Ta = ROOM TEMPERATURE				ASIS 304 18/18/2 CF8M 1.4401 - 1.4408	ASIS 316 18/18/2 CF8M 1.4401 - 1.4408	A 105/A2 16WCB	CAST IRON				
COMPOUND		CONCENTRATION	TEMPERATURE °C	ASIS 304 18/18/2 CF8M 1.4401 - 1.4408	ASIS 316 18/18/2 CF8M 1.4401 - 1.4408	A 105/A2 16WCB	CAST IRON	BRASS			
Sodium Cyanide			+20	2	2	2	2	4			
Sodium Cyanide			+20	2	2	2	2	—			
Sodium Disulphate			+20	2	2	4	4	2			
Sodium Disulphate			+20	2	2	4	4	—			
Sodium Disulphite			+20	2	2	2	2	2			
Sodium Disulphite			C	2	2	3	3	2			
Sodium Fluoride			Ta	2	2	4	4	—			
Sodium Fluoride	5%		+20	2	2	4	4	—			
Sodium Hydroxide			+20	1	1	1	1	—			
Sodium Hypochlorite			Ta	3	3	4	4	4			
Sodium Hypochlorite			+20	2	2	4	4	4			
Sodium Hypochlorate	5%		+20	4	3	4	4	4			
Sodium Hyposulphite			+20	2	2	4	4	4			
Sodium Metaphosphate			Ta	1	1	2	2	4			
Sodium Metasilicate			Cold	1	1	3	3	—			
Sodium Metasilicate			C	1	1	4	4	—			
Sodium Nitrate			+20	1	1	2	2	—			
Sodium Nitrate			Ta	2	2	2	2	3			
Sodium Perborate			Ta	2	2	2	2	—			
Sodium Peroxide			Ta	2	2	3	3	4			
Sodium Phosphate			Ta	2	2	3	3	—			
Sodium Silicate			Ta	2	2	2	2	2			
Sodium Silicate			C	2	2	3	3	2			
Sodium Silicate			Ta	2	2	2	2	—			
Sodium Sulphate	Saturated		+20	3	2	2	2	2			
Sodium Sulphate			+20	3	2	2	2	2			
Sodium Sulphite	10%	+65	3	2	2	2	2	2			
Sodium Sulphite	10%	B	3	2	4	4	2	2			
Sodium Sulphide	Saturated		+20	2	2	2	2	2			
Sodium Trisulphate	20%		+20	2	2	4	4	—			
Sodium Thiolsulphate			Ta	1	1	2	2	2			
Soft water			Ta	1	1	3	3	4			
Solvent			Ta	1	1	2	2	1			
Spirit Vinegar			+20	1	1	4	4	—			
Starch			Ta	2	2	3	3	—			
Stannic Chloride	5%		+20	4	3	4	4	—			
Stannic Chloride	5%	B	4	4	4	4	—	—			
Stannic Chloride	5%		+20	4	3	4	4	—			
Stannous Chloride	Saturated		+20	4	3	4	4	—			
Stearic Acid			+20	2	1	3	3	3			
Strontium Nitrate			+20	1	1	4	4	—			
Styrene			Ta	1	1	1	1	—			
Suds (Stearate)			Ta	1	1	1	2	—			
Sugary Juices in general			+70	2	2	4	4	4			
S Sulphur	Dry and liquefied		+230	2	2	2	2	4			
S Sulphur	Wet and liquefied		+230	3	2	4	4	4			
Sulphuric Anhydride	Dry		Ta	1	1	2	2	2			
Sulphidric Acid	dry		+20	1	1	1	1	—			
Sulphidric Acid	wet		+20	3	2	3	3	—			
Sulphuric Acid	5%		+20	3	2	4	4	4			
Sulphuric Acid	5%	B	4	3	4	4	4	—			
Sulphuric Acid	10%		+20	4	3	4	4	4			
Sulphuric Acid	10%	B	4	4	4	4	4	—			
Sulphuric Acid	50%		+20	4	4	4	4	4			
Sulphuric Acid	50%	B	4	4	4	4	4	—			
Sulphuric Acid	concentrated		+20	2	2	2	2	4			
Sulphuric Acid	concentrated	B	4	4	4	4	4	—			
Sulphuric Acid	fuming		+20	3	2	3	3	4			
Sulphur Chloride			Ta	3	2	4	4	—			
Sulphur Dioxide	Dry		+250	2	2	2	2	1			
Sulphur Dioxide	Dry		+230	2	2	2	2	4			
Sulphur Dioxide	Wet		+20	3	2	4	4	4			
Sulphurous Acid	saturated		+20	4	2	4	4	3			
Syngas			Ta	2	2	2	2	—			
T											
Tannic Acid			+20	2	2	4	4	2			
Tar			Ta	1	1	1	1	2			
Tartaric Acid	10%		+20	1	1	4	4	3			
Tartaric Acid	10%	C	3	2	4	4	3				

1 = EXCELLENT • 2 = GOOD 3 = NOT TOO GOOD • 4 = RISKY — = NO INFORMATION AVAILABLE		CONCENTRATION	TEMPERATURE °C	ASIS 304 18/18/2 CF8M 1.4401 - 1.4408		ASIS 316 18/18/2 CF8M 1.4401 - 1.4408		CARBON STEEL A 105/A2 16WCB		CAST IRON	BRASS
B = BOILING • C = HOT Ta = ROOM TEMPERATURE				ASIS 304 18/18/2 CF8M 1.4401 - 1.4408	ASIS 316 18/18/2 CF8M 1.4401 - 1.4408	A 105/A2 16WCB	CAST IRON				
COMPOUND		CONCENTRATION	TEMPERATURE °C	ASIS 304 18/18/2 CF8M 1.4401 - 1.4408	ASIS 316 18/18/2 CF8M 1.4401 - 1.4408	A 105/A2 16WCB	CAST IRON	BRASS			
Tetraethyl Lead			Ta	2	2	3	3	—			
Titanium Tetrachloride	Wet		+20	4	4	4	4	—			
Tomato Juice			Ta	1	1	3	3	4			
Toluene			Ta	1	1	1	1	1			
Tributyl Phosphate			Ta	1	1	1	1	—			
Trichloroethylene	Dry		Ta	2	2	2	3	1			
Trichloroacetic Acid			+20	4	4	4	4	3			
Tung Oil			Ta	2	2	3	3	—			
Turpentine			+20	1	1	1	1	2			
U											
Urea			Ta	2	2	3	3	—			
Uric Acid	concentrated		+20	2	2	4	4	—			
V											
Varnish			+20	1	1	3	3	1			
Varnish			C	2	2	4	4	1			
Vaseline			Ta	2	2	3	3	—			
Vinegar (vapors)			Ta	2	2	4	4	—			
Viscose			Ta	2	2	2	2	—			
W											
Waste water			+20	2	2	3	3	—			
Wax			Ta	1	1	1	1	—			
Wax Emulsions			Ta	1	1	1	1	—			
X											
Xylene	Dry		Ta	1	1	2	2	—			
Z											
Zinc Chloride	5%		+20	3	2	4	4	—			
Zinc Chloride	5%	B	4	3	4	4	—	—			
Zinc Chloride	5%		+20	3	2	4	3	4			
Zinc Hydrosulphite			Ta	1	1	1	1	—			
Zinc Sulphate	5%		+20	2	1	2	2	2			
Zinc Sulphate	25%	B	3	2	4	4	2	—			
Zinc Sulphate			Ta	2	2	4	4	4			

1 = EXCELLENT 2 = GOOD 3 = INSUFFICIENT 4 = RISKY — = NO INFORMATION AVAILABLE	DEL RIN	EP DM	N BR	VIT ON	P TF E
A					
Acetaldehyde	2	—	4	4	1
Acetal	—	—	—	—	1
Acetammide	—	1	2	2	1
Acetate Solvent	—	—	4	4	1
Acetilene	1	1	2	2	1
Acetic Acid 10-20%	4	1	1	1	1
Acetic Acid 50%	4	—	1	1	1
Acetic Acid 80%	4	1	2	2	1
Acetic Anhydride	4	—	4	4	1
Acetylene Chloride	—	—	4	1	1
Acetoacetato di Etila	—	—	4	4	1
Acetofenone	—	—	4	4	1
Acetone	1	1	4	4	1
Acetone 50% water	—	—	4	—	1
Acetonitrile	—	—	—	—	1
Acid Chloric 20%	—	—	4	4	1
Acido Laisileico	—	—	2	2	1
Acido Cresilico	4	—	4	1	1
Acrylonitrile	—	—	4	4	1
Adipic Acid	—	—	4	—	1
Air	—	1	1	1	1
Alumed Chrome	—	1	2	2	1
Alumed Potassium	—	1	2	2	1
Alumed Potassium Sulphate	—	1	—	—	1
Alumina	—	1	1	2	1
Aluminium Chloride	1	1	2	2	1
Aluminium Fluoride	—	1	2	2	1
Aluminium Hydroxide	1	1	2	2	1
Aluminium Nitrate	—	1	2	2	1
Aluminium Sulphate	1	1	2	2	1
Alum (All. Potassium Sulphate)	1	—	1	1	1
Amyl Alcohol	1	1	—	—	1
Amyl Acetate	1	4	4	4	1
Ammonium Acetate	—	1	4	—	1
Ammonia (Anhydrous)	—	1	2	4	1
Ammonia (Gas)	—	—	2	4	1
Ammonium Chloride	3	1	2	2	1
Ammonium Sulphate	1	1	2	4	1
Ammonium Sulphite 50°C	—	—	1	—	1
Ammonium Sulphide	—	1	2	4	1
Ammonium Hydroxide	—	1	2	2	1
Ammonium Fluoride 25%	—	1	—	—	1
Ammonium Phosphate	—	1	2	2	1
Ammonium Metaphosphate	—	—	2	2	1
Ammonium Nitrate	1	1	2	4	1
Ammonium Oxalate	—	1	—	—	1
Ammonium Bicarbonate	3	1	—	—	1
Ammonium Bifluoride	—	1	—	—	1
Ammonium Carbonate	3	1	2	2	1
Amyl Chloride 77°C	—	—	4	1	—
Anhydrous Formic Acid	4	—	4	2	1
Aniline	1	4	4	1	1
Aqua Regia	—	—	4	1	1
Arsenic Acid	—	1	2	2	1
Artificial Gas	—	—	2	—	1
Asphalt	1	—	4	1	1

1 = EXCELLENT 2 = GOOD 3 = INSUFFICIENT 4 = RISKY — = NO INFORMATION AVAILABLE	DEL RIN	EP DM	N BR	VIT ON	P TF E
B					
Barium Carbonate	—	1	—	—	1
Barium Chloride	1	1	2	2	1
Barium Hydroxide	—	1	2	2	1
Barium Nitrate	—	1	2	2	1
Barium Sulphate	—	1	2	2	1
Barium Sulphide	—	—	2	2	1
Beer	—	—	2	2	1
Benzaldehyde	—	—	4	4	1
Benzene, Benzol	—	—	4	4	1
Benzoic Acid	—	1	4	2	1
Benzyl Alcohol	—	—	4	1	1
Benzyl Chloride	—	—	4	—	1
Black Liquor	—	—	1	2	1
Borax	1	1	2	2	1
Boric Acid	1	1	2	2	1
Brine	—	2	1	—	1
Bromine Water	—	—	4	1	1
Butyl Acetate	—	—	—	—	1
Butyl Alcohol	1	1	4	1	1
Butyric Acid	1	4	4	—	1
Butyl Chloride	—	—	—	—	1
Butyl Phenol	—	—	—	—	1
Butyl Phthalate	—	—	4	—	1
Buffer	—	—	1	—	1
Butadiene	1	—	1	1	1
Butane	1	1	4	1	1
Butylene	1	—	4	2	1
C					
Calcium Bisulphite	1	1	2	2	1
Calcium Bicarbonate	—	—	—	—	1
Calcium Carbonate	1	1	2	2	1
Calcium Chlorate	—	—	2	2	1
Calcium Chloride	1	1	2	2	1
Calcium Disulphate	—	—	—	—	1
Calcium Fluoride	—	—	—	—	1
Calcium Hydroxide	1	1	2	2	1
Calcium Hypochlorite	1	1	4	2	1
Calcium Nitrate	—	1	2	2	1
Calcium Oxide 20°C	—	—	—	—	1
Calcium Sulphate	1	1	—	—	1
Cane Sugar Liquor	—	1	2	2	1
Carbolic Acid (Phenol)	—	—	4	4	1
Carbonic Acid	4	1	2	2	1
Carbon Bisulphide	—	—	4	2	1
Carbon Dioxide	—	—	1	—	1
Carbon Monoxide	—	1	2	2	1
Castor Oil	1	1	2	2	1
Caustic Soda	—	1	3	—	1
Cellulose Acetate	—	1	4	4	1
Cellosolve	—	1	4	4	1
Cement	—	1	2	—	1
Cereal Syrup (Glucose)	—	—	2	2	1
Chloroacetic Acid	—	—	4	4	1
Chloroform	1	4	4	2	1
Chlorosulfonic Acid	—	—	—	—	1
Chlorine Dioxide	—	—	4	—	—
Chlorine Water	—	—	4	1	1

1 = EXCELLENT 2 = GOOD 3 = INSUFFICIENT 4 = RISKY — = NO INFORMATION AVAILABLE	DEL RIN	EP DM	N BR	VIT ON	P TFE
Chlorine Water	—	—	4	—	1
Chlorobenzene	1	4	4	2	1
Chromic Acid	4	—	2	1	1
Chromic Anhydride	—	—	2	1	1
Chrome Potassium Sulphate	—	—	2	—	1
Citric Acid	—	1	2	2	1
Coconut Oil	1	—	2	1	1
Coffee	—	1	4	1	1
Coke-oven Gas	—	1	4	2	1
Copper Acetate	—	—	—	4	1
Copper Chloride	1	1	2	2	1
Copper Nitrate	1	—	2	2	1
Copper Sulphate	1	1	2	2	1
Corn Oil	1	—	4	—	1
Cotton seeds Oil	—	—	2	1	1
Creosote	—	4	3	1	1
Cresol	—	—	4	4	1
Cromil Chloride	—	—	—	—	1
Crotonaldehyde	—	—	—	—	1
Crude Oil	—	—	2	1	1
Cyanoacetic Acid	—	—	—	—	1
Cyanogen Gas	—	1	—	—	1
Cyclohexane	—	4	2	2	1
D					
Deminerzalized Water	—	1	2	2	1
Detergents	—	1	2	2	1
Dextrine	—	—	4	4	1
Dextrose	—	—	2	2	1
Diacetone	—	1	4	4	1
Diacetone Alcohol	—	—	4	—	1
Dibutylphthalate	—	—	—	2	1
Dichloroethane	—	—	4	1	1
Dichlorobenzene max 40°C	—	—	—	2	1
Dichloroethane	—	—	4	2	1
Dichloroethylene	—	—	4	2	1
Diethyl Ether	—	—	4	4	1
Diethyl Ether 40°C	—	—	2	4	1
Diethylcellosolve	—	—	—	—	1
Diethylamine max 40°C	—	—	4	—	1
Dimethyl	—	—	—	4	1
Dimethylphthalate	—	—	4	1	1
Dimethyl Ether	—	—	—	—	1
Dioxan	—	4	4	4	1
Diphenyl (Dowtherms)	—	—	4	1	1
Disodium Phosphate 20°C	—	—	4	2	1
Distilled Water	1	1	2	2	1
Dry Sulphur Dioxide	4	—	4	4	1
Drilling Sludge	—	4	1	—	1
Drilling Sludge	—	4	1	—	1
Dry Sulphurized Hydrogen	—	1	—	4	1
Dry Sulphurized Hydrogen	—	1	—	4	1
Dyes	—	4	4	—	1
Dyes	—	4	4	—	1
E					
Ethyl Acetate	1	4	4	4	1
Ethyl Acrylate	—	1	2	2	1
Ethyl Alcohol	1	1	3	1	1
Ethyl Chloride	1	—	2	2	1

1 = EXCELLENT 2 = GOOD 3 = INSUFFICIENT 4 = RISKY — = NO INFORMATION AVAILABLE	DEL RIN	EP DM	N BR	VIT ON	P TFE
Ethyl Glycol	—	1	1	1	1
Ethylene Bromide	—	—	4	—	1
Ethylene Chloride	—	—	4	1	1
Ethylene Diamine	—	—	1	1	1
Ethylene Glycol	—	1	2	1	1
Ethylene Oxide	—	—	4	4	1
Epichlorohydrin	—	—	4	4	1
F					
Fats	—	4	1	—	1
Fatty Acids	—	—	2	2	1
Ferric Chloride	1	1	2	2	1
Ferric Nitrate 10-50%	—	1	2	2	1
Ferric Sulphate	1	1	2	2	1
Ferrous Chloride	1	1	2	—	1
Ferrous Sulphate	1	1	2	2	1
Fluorinated Hydrogen	—	—	2	2	1
Fluorine Gas	—	—	4	4	1
Fluorosilicic Acid	—	1	3	—	—
Formaldehyde 35-50%	1	1	4	4	1
Formic Acid 10-85%	4	1	4	2	1
Freon F 11-12	—	—	2	2	—
Freon F 22	—	—	4	4	—
Fuel Oil	1	4	2	1	1
Fuel for aircrafts (JP4 or JP5)	—	4	2	1	1
Furfural	—	—	4	4	1
Furfuraldehyde	1	—	4	4	1
G					
Gallic Acid	1	1	—	2	1
Galvanizing Solution	—	1	2	2	1
Gaseous Bromine	2	4	4	—	1
Gaseous Oxygen	1	—	4	2	1
Gas Oil	—	—	2	2	1
Gelatine	1	—	2	2	1
Glucose	1	—	2	2	1
Glue	—	1	3	—	1
Glycerol	3	—	2	1	1
Glycols 60°C	—	—	1	1	1
Glycolic Acid	—	1	—	—	1
Green Liquor	—	1	2	—	1
H					
Helium	—	2	2	—	1
Heptane	—	1	2	1	1
Hexane	—	4	2	1	1
Hexanol	—	—	2	1	1
Hydraulic Fluid	—	—	2	1	1
Hydrobromic Acid	—	—	4	2	1
Hydrocyanic Acid	—	1	2	2	1
Hydrochloric Acid max 50%	—	1	—	2	1
Hydrofluoric Acid max 70%	—	—	4	1	—
Hydrofluoric Acid 100%	—	—	4	—	—
Hydrogen Dioxide	1	1	4	1	1
Hydrogen Chloride	—	—	—	—	1
Hydrogen	—	1	2	2	1
Hydrogen Sulphide	—	—	4	4	1
Hydroquinone	—	1	4	2	1
I					
Ink	—	1	—	—	—
Industrial oils	—	—	—	—	1

1 = EXCELLENT 2 = GOOD 3 = INSUFFICIENT 4 = RISKY -- = NO INFORMATION AVAILABLE	DEL RIN	EP DM	N BR	VIT ON	PT FE
Iodoform	1	—	4	1	1
Isobutyl-Methyl-Ketone	—	—	4	4	1
Isocotane	1	4	1	1	1
Isopropyl Alcohol	1	1	3	2	1
Isopropyl Ether	—	—	4	4	1
J					
Juices	1	2	2	—	1
K					
Kerosene	—	—	2	1	1
L					
Lactic Acid	4	—	4	2	1
Lard Oil	—	—	1	1	1
Lead Acetate	1	—	4	4	1
Lead Chloride max 20°C	—	—	—	2	1
Lead Sulphate	—	—	3	—	1
Leaded Petrol	1	—	2	2	1
Lemon Oil	—	2	3	—	1
Lime	—	1	4	—	1
Lime Sulphur	—	1	4	2	1
Linseed Oil	1	—	2	1	1
Liquid Chlorine	—	—	4	2	1
Liquid Soap	—	1	2	—	1
Lithium Bromine	—	1	2	2	1
Lubricating Oil	—	—	2	2	1
M					
Maleic Acid	1	1	4	2	1
Malic Acid	1	—	2	2	1
Manganese Chloride max 20°C	—	—	2	2	1
Magnesium Carbonate	—	—	2	—	1
Magnesium Chloride	1	1	2	2	1
Magnesium Hydroxide	1	1	2	2	1
Magnesium Nitrate	—	1	2	—	1
Magnesium Oxide	—	2	2	—	1
Machine Oil	—	—	—	—	1
Magnesium Sulphate	1	1	2	—	1
Methane	1	1	2	1	1
Methanol	—	1	2	4	1
Methyl Acetate	—	3	4	4	1
Methyl Alcohol	1	1	2	4	1
Methyl Bromine	—	—	—	2	1
Methyl Chloride	—	—	4	2	1
Methyl Methacrylate	—	—	2	2	1
Methylene Chloride	—	4	4	4	1
Methylacetone	—	2	4	4	1
Methylcellosolve	—	—	3	4	1
Methyl-Ethyl-Ketone	—	—	4	4	1
Mercury	1	—	2	2	1
Mercuric Chloride	—	1	2	2	1
Mercuric Nitrate	—	1	—	—	1
Milk	1	—	2	2	1
Mineral Oil	1	—	2	2	1
Mineral Water	1	1	2	—	1
Mineral Naphtha (Combustible Oil)	1	4	2	1	1
Mixed Acids (*T max 32°C)	—	1	1	1	1
Molasses	—	1	2	2	1
Monochlorobenzene 20°C	—	—	4	1	1
Motor Oil	—	—	2	2	1
n Butyl Mercaptan	—	—	—	—	1

1 = EXCELLENT 2 = GOOD 3 = INSUFFICIENT 4 = RISKY -- = NO INFORMATION AVAILABLE	DEL RIN	EP DM	N BR	VIT ON	PT FE
N					
Naphthalene	1	—	4	2	1
Natural Gas	1	1	2	2	1
Nickel Ammonium Sulphate	—	—	—	—	1
Nickel Chloride	1	1	2	—	1
Nickel Nitrate	1	—	2	2	1
Nickel Salt	—	—	2	—	1
Nickel Sulphate	1	1	2	2	1
Nicotine	—	—	—	—	1
Nicotinic Acid	—	1	—	—	1
Nitric Acid	4	4	4	2	1
Nitrobenzene 25°C	—	2	4	4	1
Nitrobenzene over 25°C	—	—	4	4	1
Nitrogen	1	1	2	—	1
Nitromethane	—	—	4	—	1
Nitrous Oxide 40°C	—	—	4	3	1
O					
Oleum	4	—	4	1	1
Oleic Acid	1	—	1	4	1
Oli Vegetali	—	1	2	2	1
Olive Oil	—	2	1	1	1
Oxalic Acid	3	1	1	2	1
Oxygen	1	1	3	2	1
Ozone	—	—	4	2	1
P					
Paint Solvents	—	4	4	4	1
Palmitic Acid	1	—	2	2	1
Paraffin wax	1	—	2	—	1
Perchloric Acid	—	—	4	2	1
Perchloroethylene	—	4	4	1	1
Persolfato di Ammonio	—	1	2	—	1
Petrol Oils (acid or refined oils)	—	—	2	2	1
Petrolatum (Vaseline)	—	—	—	—	1
Phenyl Chloride (Chlorobenzene)	—	—	4	1	1
Phenylhydrazine	—	—	4	2	1
Phenol (Carbolic Acid)	4	—	4	1	—
Phosphate 50°C	—	—	—	—	1
Phosphoric Acid 10%	4	—	4	2	1
Phosphoric Acid 25/50%	4	—	4	2	1
Phosphoric Acid 50/80%	4	1	4	2	1
Phosphorus Oxichloride	—	—	—	—	1
Phosphorous Pentoxide 20°C	—	—	—	—	1
Phosphorous Pentoxide	—	—	4	4	1
Phthalic Acid	1	—	4	—	1
Phthalic Anhydride	—	—	4	2	1
Picric Acid	—	1	3	2	1
Pickling solution	—	4	—	—	1
Polyvinyl Acetate	—	1	—	—	1
Potassium Bicarbonate	—	—	2	2	1
Potassium Bichromate (30%)	—	—	4	4	1
Potassium Bromide	1	1	2	2	1
Potassium Carbonate 50%	1	—	2	2	1
Potassium Chlorate	—	1	2	2	1
Potassium Chloride	1	1	2	2	1
Potassium Chromate 30%	—	1	—	—	1
Potassium Cyanide 30%	1	1	2	2	1
Potassium Ferricyanide 30%	—	—	2	2	1
Potassium Fluoride	—	—	2	2	1

Coupling dimensions (in mm) of the flanges for nominal pressures

FLANGES UNI-DIN

DN	PN6				PN10				PN16				PN25				PN40				PN64				PN100				PN160						
	D	N.	f	α	D	N.	f	α	D	N.	f	α	D	N.	f	α	D	N.	f	α	D	N.	f	α	D	N.	f	α	D	N.	f	α	D	N.	f
10	75	4	11	50	90	4	14	60	90	4	14	60	90	4	14	60	90	4	14	60	100	4	14	70	100	4	14	70	100	4	14	70			
15	80	4	11	55	95	4	14	65	95	4	14	65	95	4	14	65	95	4	14	65	105	4	14	75	105	4	14	75	105	4	14	75			
20	90	4	11	65	105	4	14	75	105	4	14	75	105	4	14	75	105	4	14	75	130	4	18	90	130	4	18	90	130	4	18	90			
25	100	4	11	75	115	4	14	85	115	4	14	85	115	4	14	85	115	4	14	85	140	4	18	100	140	4	18	100	140	4	18	100			
32	120	4	14	90	140	4	18	100	140	4	18	100	140	4	18	100	140	4	18	100	155	4	22	110	155	4	22	110	155	4	22	110			
40	130	4	14	100	150	4	18	110	150	4	18	110	150	4	18	110	150	4	18	110	170	4	22	125	170	4	22	125	170	4	22	125			
50	140	4	14	110	165	4	18	125	165	4	18	125	165	4	18	125	165	4	18	125	180	4	22	135	195	4	25	145	195	4	25	145			
65	160	4	14	130	185	4	18	145	185	4	18	145	185	4	18	145	185	4	18	145	205	4	22	160	220	4	25	170	220	4	25	170			
80	190	4	18	150	200	4	18	160	200	4	18	160	200	4	18	160	200	4	18	160	215	4	22	170	230	4	25	180	230	4	25	180			
100	210	4	18	170	220	4	18	180	220	4	18	180	235	4	22	190	235	4	22	190	250	4	25	200	265	4	30	210	265	4	30	210			
125	240	8	18	200	250	8	18	210	250	8	18	210	270	8	25	220	270	8	25	220	295	8	30	240	315	8	33	250	315	8	33	250			
150	265	8	18	225	285	8	22	240	285	8	22	240	300	8	25	250	300	8	25	250	345	8	33	280	355	12	33	290	355	12	33	290			
200	320	8	18	280	340	8	22	295	340	12	22	295	360	12	25	310	375	12	30	320	415	12	36	345	430	12	36	360	430	12	36	360			
250	375	12	18	335	395	12	22	350	405	12	25	355	425	12	30	370	450	12	33	385	470	12	36	400	505	12	39	430	515	12	42	430			
300	440	12	22	395	445	12	22	400	460	12	25	410	485	16	30	430	515	16	33	450	530	16	36	460	585	16	42	500	585	16	42	500			
350	490	12	22	445	505	16	22	460	520	16	25	470	555	16	33	490	580	16	36	510	600	16	39	525	655	16	48	560							
400	540	16	22	495	565	16	25	515	580	16	30	525	620	16	36	550	660	16	39	585	670	16	42	585	715	16	48	620							
(450)	595	16	22	550	615	20	25	565	640	20	30	585	670	20	36	600	685	20	39	610	715	20	42	630	770	20	48	675							
500	645	20	22	600	670	20	25	620	715	20	33	650	730	20	36	660	755	20	42	670	800	20	48	705	870	20	56	760							
600	755	20	25	705	780	20	30	725	840	20	36	770	845	20	39	770	890	20	48	795	930	20	56	820	990	20	62	875							

FLANGES ANSI

Inch	ANSI 150				ANSI 300				ANSI 600			
	D	N.	f	α	D	N.	f	α	D	N.	f	α
1/2	89	4	16	61	95	4	16	67	95	4	16	67
3/4	98	4	16	70	118	4	19	83	118	4	19	83
1	108	4	16	80	124	4	19	89	124	4	19	89
1 1/4	118	4	16	89	133	4	19	99	133	4	19	99
1 1/2	127	4	16	99	156	4	23	115	156	4	23	115
2	152	4	19	121	165	8	19	127	165	8	19	127
2 1/2	178	4	19	140	191	8	23	150	191	8	23	150
3	191	4	19	153	210	8	23	169	210	8	23	169
4	229	8	19	191	254	8	23	200	273	8	26	216
5	254	8	23	216	279	8	23	235	330	8	29	267
6	279	8	23	242	318	12	23	270	356	12	29	293
8	343	8	23	299	381	12	26	331	419	12	32	350
10	406	12	26	362	445	16	29	388	508	16	35	432
12	483	12	26	432	521	16	32	451	559	20	35	489
14	533	12	29	477	584	20	32	515	603	20	38	527
16	597	16	29	540	648	20	35	572	686	20	42	604
18	635	16	32	587	711	24	35	629	743	20	45	654
20	699	20	32	635	775	24	35	686	813	24	45	724
24	813	20	35	750	914	24	42	813	940	24	51	839

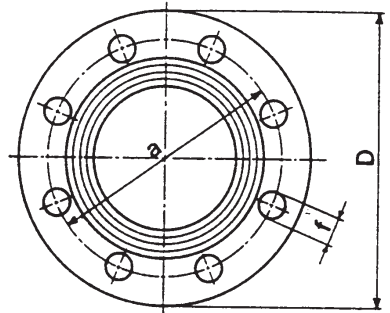

STEAM TABLE

PTFE + CARBOGRAPHITE

PRESSIONE (BAR) p	TEMPERATURE (°C) t
0,010	7,0
0,020	17,5
0,030	24,1
0,040	29,0
0,050	32,9
0,060	36,2
0,070	39,0
0,080	41,5
0,090	43,8
0,10	45,8
0,20	60,1
0,30	69,1
0,40	75,9
0,50	81,3
0,60	86,0
0,70	90,0
0,80	93,5
0,90	96,7

PRESSIONE (BAR) p	TEMPERATURE (°C) t
1,00	99,6
1,5	111,4
2,0	120,2
2,5	127,4
3,0	133,5
3,5	138,9
4,0	143,6
4,5	147,9
5,0	151,8
6,0	158,8
7,0	164,9
8,0	170,4
9,0	175,4
10	179,9
11	184,1
12	188
13	191,6

VACUUM GRADE

*The pressure is expressed
in TORR (1 TORR = mmttg)*

GRADE	PRESSURE
Low vacuum	760 to 1
Medium vacuum	1 to 10 ⁻³
High vacuum	10 ⁻³ to 10 ⁻⁷
Very high vacuum	10 ⁻⁷ to 10 ⁻⁹
Ultra high vacuum	less than 10 ⁻⁹

MEASUREMENT UNITS CONVERSION

PRESSURE			
Si	Pascal	Pa	1 Pa = 1 N/m ² 1 kPa = 0,01 bar = 1 N/cm ²
(I)	-	bar	1 bar = 100.000 Pa = 1,019 kg/cm ² = 14,48 psi = 10,19 mHzO
Engl.	Pounds per square inch	psi	1 psi = 6,906 kPa = 0,068 bar = 0,0703 kg/cm ²
Tec.	Metric atmosphere	at	1 at = 1 kg/cm ² = 736 mm di Hg = 10 mHzO = 98.066,50 Pa
Tec.	Metric atmosphere	kg/cm ²	1 kg/cm ² = 98,067 kPa = 0,980 bar = 0,967 atm
Tec.	Standard atmosphere	atm	1 atm = 101.325 Pa = 760 mm di Hg = 1,033 at = 1 torr

TEMPERATURE			
Si	Kelvin	K	1 K = °C + 273,15
Si	Celsius	°C	1°C = (°F - 32) x 5/9 = K - 273,15
Engl.	Fahrenheit	°F	1 °F = 9/5 x °C + 32

PROTECTION RATE OF BOXES FOR ELECTRIC MATERIAL

(according to NF EN 60529 and CEI 529)

P symbol, followed by two figures: for example IP65

The first figure shows the protection rate against live parts, internal moving parts, introduction of foreign matters

The second figure shows the protection rate from penetration of fluids.

1st figure

2nd figure

1 st figure		2 nd figure	
DESCRIZIONE	TEST	DESCRIZIONE	TEST
0	not protected	0	not protected
1	protected from solid bodies above \varnothing 50mm	1	splashproof from vertical water drops of water (condensed water)
2	protected from solid bodies above \varnothing 12mm	2	splashproof from vertical water drops up to 15°
3	protected from solid bodies above \varnothing 2,5mm	3	splashproof from rain up to 60°
4	protected from solid bodies above \varnothing 1mm	4	splashproof from all directions
5	protected from dust (no dangerous deposit)	5	splashproof from water spouts (from all directions)
6	full protection from dust	6	splashproof from sea waves and similar splashes
		7	splashproof from the effects of immersion
		8	splashproof from the effects of submersion



UNI EN ISO 9001: 2000
Progettazione, Sviluppo, Fabbricazione
Certificato n° 0024/3



EFFEBI Spa
Via Giuseppe Verdi, 68 - 25073 Bovezzo (Bs)
Telefono +39 030 211010 - Fax +39 030 2110301 (ITALIA)
Fax +39 030 2110302 (Export) - Internet: www.effebi.it - E-mail: effebi@effebi.it